

FEATURES

- Ultra Broad Bandwidth : 50 MHz to 50 GHz
- Functional Bandwidth : 50 MHz to 70 GHz
- 0.5 dB Insertion Loss at 50GHz
- 46 dB Isolation at 50 GHz
- Low Current consumption
 - -5V for low loss state
 - +10mA for Isolation state
- Silicon Nitride Passivation
- Polymer Scratch protection
- RoHS Compliant* and 260°C Reflow Compatible

DESCRIPTION

The MA4AGSW1A is an Aluminum-Gallium-Arsenide, single pole, single throw (SPST), absorptive PIN diode switch. The switch features enhanced AlGaAs anodes which are formed using M/A-COM Tech's patented hetero-junction technology. This technology produces a switch with less loss than conventional GaAs processes. As much as a 0.3 dB reduction in insertion loss can be realized at 50GHz. These devices are fabricated on an OMCVD epitaxial wafer using a process designed for high device uniformity and extremely low parasitics. The diodes themselves exhibit low series resistance, low capacitance, and fast switching speed. They are fully passivated with silicon nitride and have an additional polymer layer for scratch protection. The protective coating prevents damage to the diode junction and anode air-bridges during handling and assembly. Off chip bias circuitry is required.

APPLICATIONS

The output port of this device, J2, is terminated into 50Ω during isolation mode, which allows this signal to be absorbed rather than reflected back. This functionality makes it ideal for instrumentation and radar applications. An absorptive switch can be added to other AlGaAs reflective switches to improve isolation VSWR and increase isolation magnitude. The ultra low capacitance of the PIN diodes makes it ideal for usage in low loss and high isolation microwave and millimeter wave switch designs through 70 GHz. The lower series resistance of the AlGaAs diodes reduces the total insertion loss and distortion of the device. AlGaAs PIN switches are used in applications such as switching arrays for radar systems, radiometers, and other multi-function components.

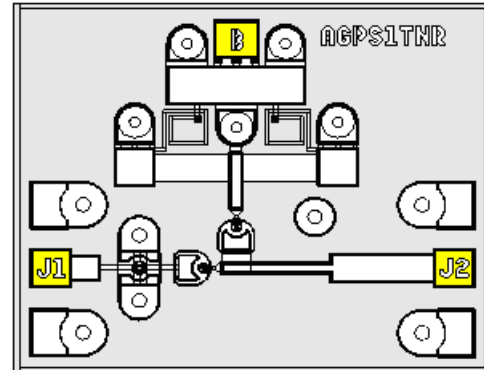

Yellow areas indicate bond pads

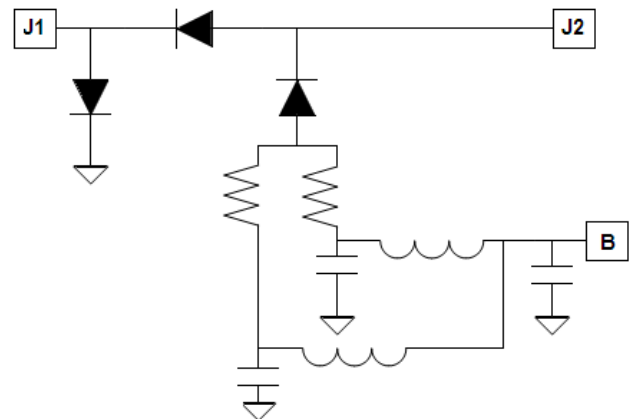

Absolute Maximum Ratings @ T_{AMB} = +25°C

Parameter	Maximum Rating
Operating Temperature	-55°C to +125°C
Storage Temperature	-55°C to +150°C
Incident C.W. RF Power	+23dBm C.W.
Breakdown Voltage	25V
Bias Current	± 25mA
Junction Temperature	+150°C

Maximum combined operating conditions for RF Power, D.C. bias, and temperature: +23 dBm C.W. @ 10 mA (per diode) @ +85°C.

* Restrictions on Hazardous Substances, European Union Directive 2002/95/EC.

**Electrical Specifications @ $T_{AMB} = 25^{\circ}C$
(On-wafer measurements)**

Parameter	Ports	Bias Conditions	Frequency	Typical
Insertion Loss	J1 - J2	-5V at J1 and B	50GHz	1.2dB
Isolation	J1 - J2(Terminated by 50Ω)	+10mA at J1 and B	50GHz	30dB
Input return Loss	J1- J2	-5V at J1 and B	50GHz	15dB
Output Return Loss	J2- J1	-5V at J1 and B	50GHz	18dB
Output Return Loss (Isolation)	J2(Terminated by 50Ω)	+10mA at J1 and B	50GHz	18dB
Switching Speed (10% - 90% RF Voltage)	J1 - J2	±5V PIN TTL Driver	10GHz	10nS
		1MHz Repetition Frequency.		

Notes:

1. Typical switching speed is measured from 10% to 90% of the detected RF voltage driven by a TTL compatible driver. Driver output parallel RC network uses a capacitor between 390 pF - 560 pF and a resistor between 150 - 220 Ohms to achieve 10 ns rise and fall times.
2. Bias nodes, J1 and B may be connected together

Typical RF Performance (Probed on Wafer)

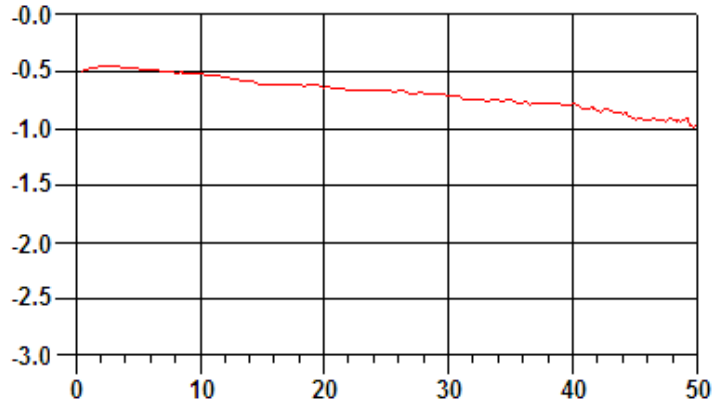

Isolation

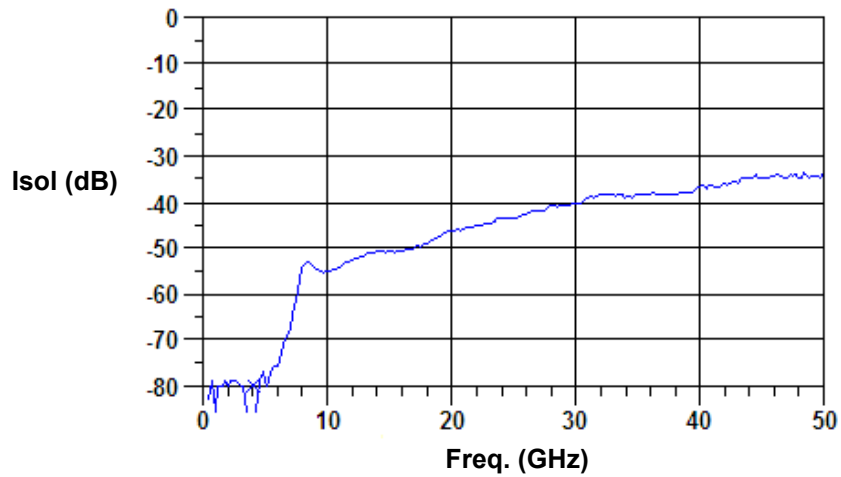

Input Return Loss

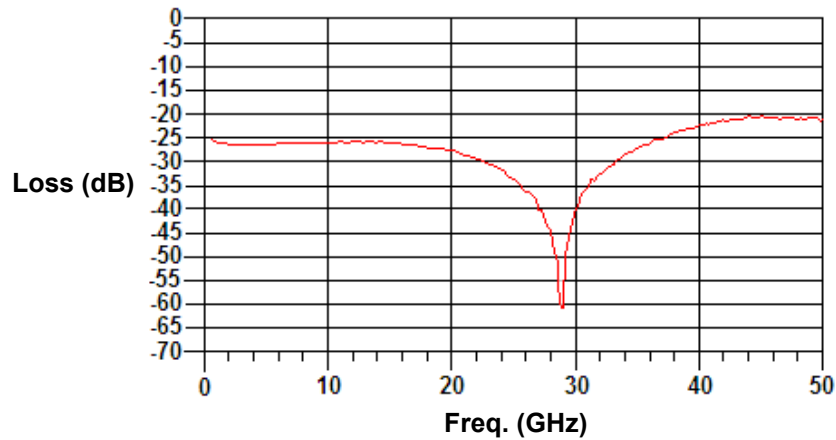

Typical RF Performance (Probed on wafer)

Output Return Loss (Insertion Loss State)

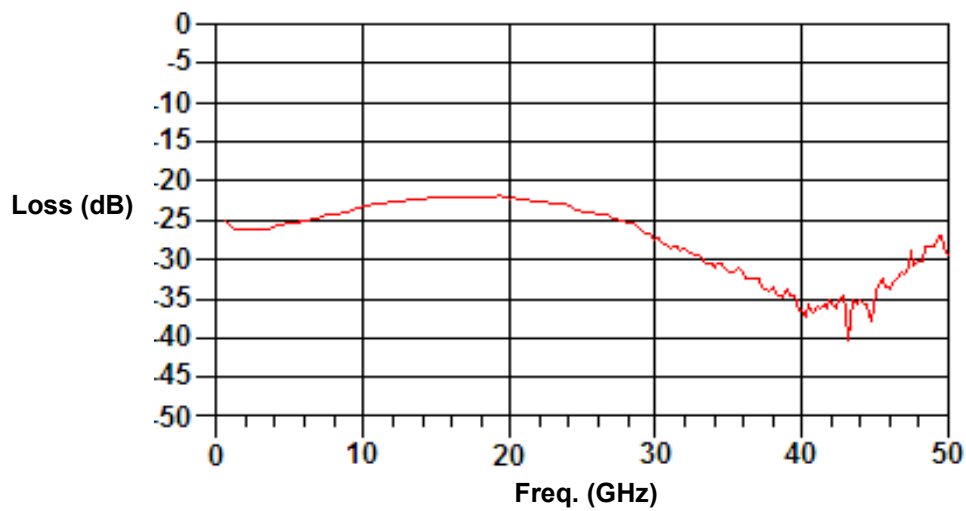

Output Return Loss (Isolation Loss State)

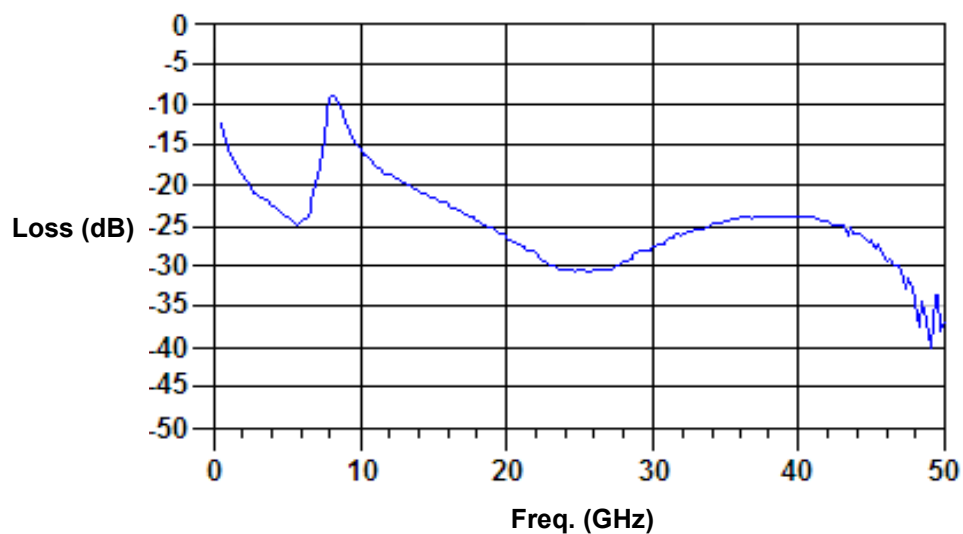

Operation of the MA4AGSW1A Switch

An external bias network and D.C return is required for successful operation of the MA4AGSW1A absorptive SPST AlGaAs PIN diode switch. The backside area of the die is the RF and D.C. ground return plane. In the low loss state, the series diode is forward biased with negative current at D.C. Bias B1 and the match diode is biased at 0V at D.C. Bias B. In the isolated state, the shunt diode and the match diode are both forward biased at D.C. Bias B1 and D.C. Bias B (series diode becomes reverse biased). This isolation state bias results in a good 50Ω match into Port J2. Typical driver connections are shown in Table I below. The bias network design shown in the schematic should yield > 30dB RF to DC isolation.

Available for use in conjunction with M/A-COM Tech's line of AlGaAs switches are two, fully integrated, broad-band, monolithic, bias networks which may be used as an alternative to the suggested individual component bias network shown below. Refer to datasheets for the [MA4BN1840-1](#) and [MA4BN1840-2](#) for additional information.

The lowest insertion loss, P1dB, IP³, and switching speed is achieved by applying a minimum value of | -2V | at D.C. Bias node, which is achievable with a standard, ± 5V TTL Controlled PIN Diode Driver.

MA4AGSW1A Schematic with Bias Network for 10-30GHz

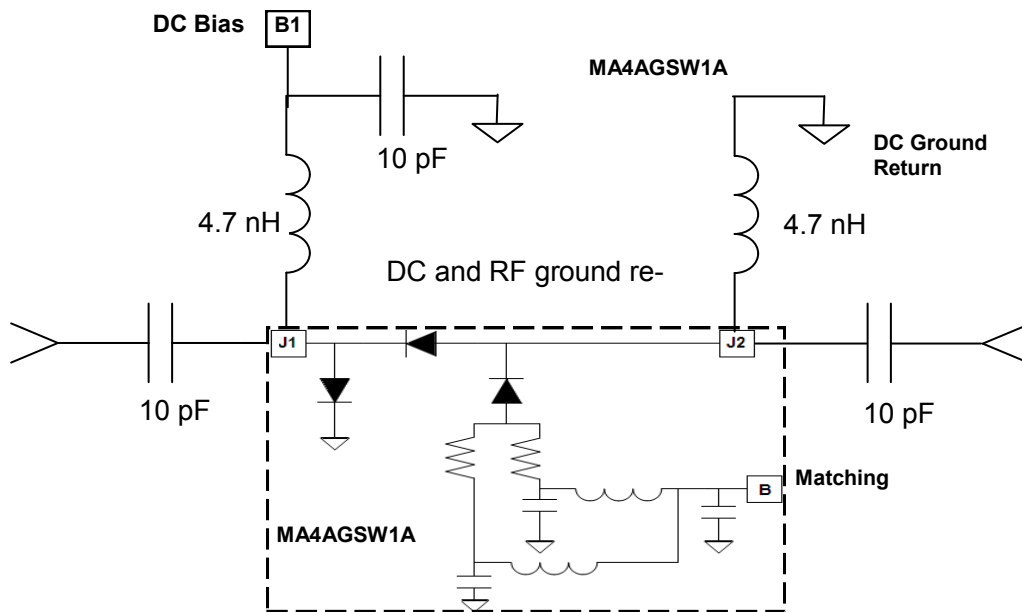

Notes:

1. D.C. Bias 1 and D.C. Bias B nodes can be connected together.
2. Diode junction forward bias voltage, $\Delta V_f @ 10 \text{ mA} \sim 1.35 \text{ V} @ + 25^\circ \text{ C}$.

TYPICAL DRIVER CONNECTIONS

J1-J2 Low Loss : Good VSWR at J1 & J2	J1-J2 Isolation : Good VSWR at J2
D.C. Bias 1 = -10mA	D.C. Bias 1 = +10mA
D.C. Bias B = 0V	D.C. Bias B = +10mA

Chip Dimensions and Bonding Pad Locations (In Yellow)

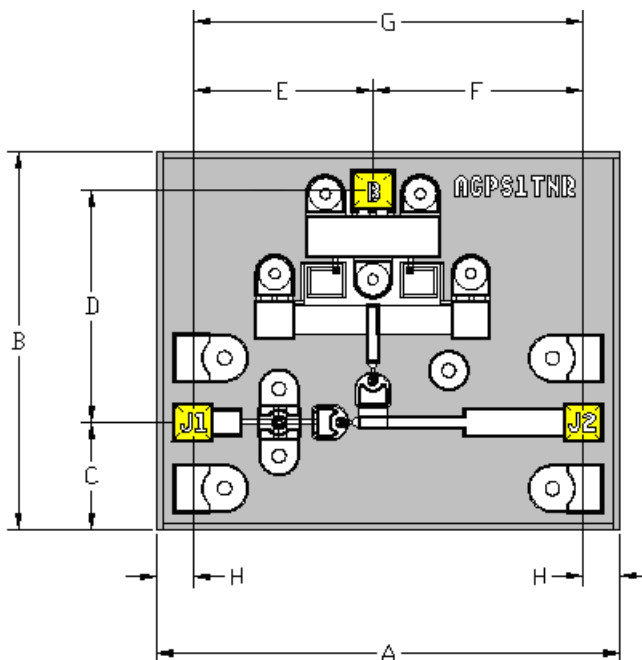

Dimension	mils		mm	
	Min	Max	Min	Max
A	44.9	46.9	1.14	1.19
B	36.9	38.9	0.94	0.99
C	10.4	11.4	0.26	0.29
D	22.8	23.4	0.58	0.59
E	17.3	17.9	0.44	0.45
F	20.3	20.9	0.52	0.53
G	37.9	38.5	0.96	0.98
H	3.4	4.4	0.09	0.11
Thickness	3.5	4.5	0.09	0.11

ASSEMBLY INSTRUCTIONS

CLEANLINESS

These chips should be handled in a clean environment.

STATIC SENSITIVITY

These Devices are considered ESD Class 1A, HBM. Proper ESD techniques should be used when handling these devices.

GENERAL HANDLING

The protective polymer coating on the active areas of the die provides scratch and impact protection, particularly for the metal air bridge, which contacts the diode's anode. Die should primarily be handled with vacuum pickup tools, or alternatively with plastic tweezers.

ASSEMBLY TECHNIQUES

The MA4AGSW1A, AlGaAs device is designed to be mounted with electrically conductive silver epoxy or with a low temperature solder perform, which does not have a rich tin content.

SOLDER DIE ATTACH

Only solders which do not scavenge gold, such as 80Au/Sn20, or Indalloy #2 is recommended. Do not expose die to temperatures greater than 300°C for more than 10 seconds.

ELECTRICAL CONDUCTIVE EPOXY DIE ATTACH

Use a controlled thickness of approximately 2 mils for best electrical conductivity and lowest thermal resistance. Cure epoxy per manufacturer's schedule. Typically 150°C for 1 hour.

RIBBON/WIRE BONDING

Thermo-compression wedge or ball bonding may be used to attach ribbons or wire to the gold bonding pads. A 1/4 x 3 mil gold ribbon is recommended on all RF ports and should be kept as short as possible for the lowest inductance and best microwave performance. For more detailed handling and assembly instructions, see [Application Note M541](#), "Bonding and Handling Procedures for Chip Diode Devices" at www.macomtech.com.

Ordering Information

Part Number	Package
MA4AGSW1A	Waffle Pack

M/A-COM Technology Solutions Inc. All rights reserved.

Information in this document is provided in connection with M/A-COM Technology Solutions Inc ("MACOM") products. These materials are provided by MACOM as a service to its customers and may be used for informational purposes only. Except as provided in MACOM's Terms and Conditions of Sale for such products or in any separate agreement related to this document, MACOM assumes no liability whatsoever. MACOM assumes no responsibility for errors or omissions in these materials. MACOM may make changes to specifications and product descriptions at any time, without notice. MACOM makes no commitment to update the information and shall have no responsibility whatsoever for conflicts or incompatibilities arising from future changes to its specifications and product descriptions. No license, express or implied, by estoppel or otherwise, to any intellectual property rights is granted by this document.

THESE MATERIALS ARE PROVIDED "AS IS" WITHOUT WARRANTY OF ANY KIND, EITHER EXPRESS OR IMPLIED, RELATING TO SALE AND/OR USE OF MACOM PRODUCTS INCLUDING LIABILITY OR WARRANTIES RELATING TO FITNESS FOR A PARTICULAR PURPOSE, CONSEQUENTIAL OR INCIDENTAL DAMAGES, MERCHANTABILITY, OR INFRINGEMENT OF ANY PATENT, COPYRIGHT OR OTHER INTELLECTUAL PROPERTY RIGHT. MACOM FURTHER DOES NOT WARRANT THE ACCURACY OR COMPLETENESS OF THE INFORMATION, TEXT, GRAPHICS OR OTHER ITEMS CONTAINED WITHIN THESE MATERIALS. MACOM SHALL NOT BE LIABLE FOR ANY SPECIAL, INDIRECT, INCIDENTAL, OR CONSEQUENTIAL DAMAGES, INCLUDING WITHOUT LIMITATION, LOST REVENUES OR LOST PROFITS, WHICH MAY RESULT FROM THE USE OF THESE MATERIALS.

MACOM products are not intended for use in medical, lifesaving or life sustaining applications. MACOM customers using or selling MACOM products for use in such applications do so at their own risk and agree to fully indemnify MACOM for any damages resulting from such improper use or sale.

8

M/A-COM Technology Solutions Inc. (MACOM) and its affiliates reserve the right to make changes to the product(s) or information contained herein without notice.
Visit www.macom.com for additional data sheets and product information.