

Excellent Integrated System Limited

Stocking Distributor

Click to view price, real time Inventory, Delivery & Lifecycle Information:

[Vishay Semiconductor/Diodes Division](#)
[208CMQ060](#)

For any questions, you can email us directly:

sales@integrated-circuit.com

International **IR** Rectifier

208CMQ060

SCHOTTKY RECTIFIER

200 Amp

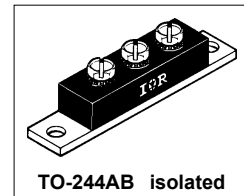

Major Ratings and Characteristics

| Characteristics | 208CMQ... | Units |
|--|------------|------------------|
| $I_{F(AV)}$ Rectangular waveform | 200 | A |
| V_{RRM} | 60 | V |
| I_{FSM} @tp = 5 μ s sine | 16,000 | A |
| V_F @100Apk, $T_J = 125^\circ\text{C}$ (per leg) | 0.59 | V |
| T_J range | -55 to 150 | $^\circ\text{C}$ |

Description/Features

The 208CMQ high current Schottky rectifier module series has been optimized for low reverse leakage at high temperature.

The proprietary barrier technology allows for reliable operation up to 150 $^\circ\text{C}$ junction temperature. Typical applications are in high current switching power supplies, plating power supplies, UPS systems, converters, free-wheeling diodes, welding, and reverse battery protection.

- 150 $^\circ\text{C}$ T_J operation
- Center tap module - Isolated Base
- High purity, high temperature epoxy encapsulation for enhanced mechanical strength and moisture resistance
- Low forward voltage drop
- High frequency operation
- Guard ring for enhanced ruggedness and long term reliability

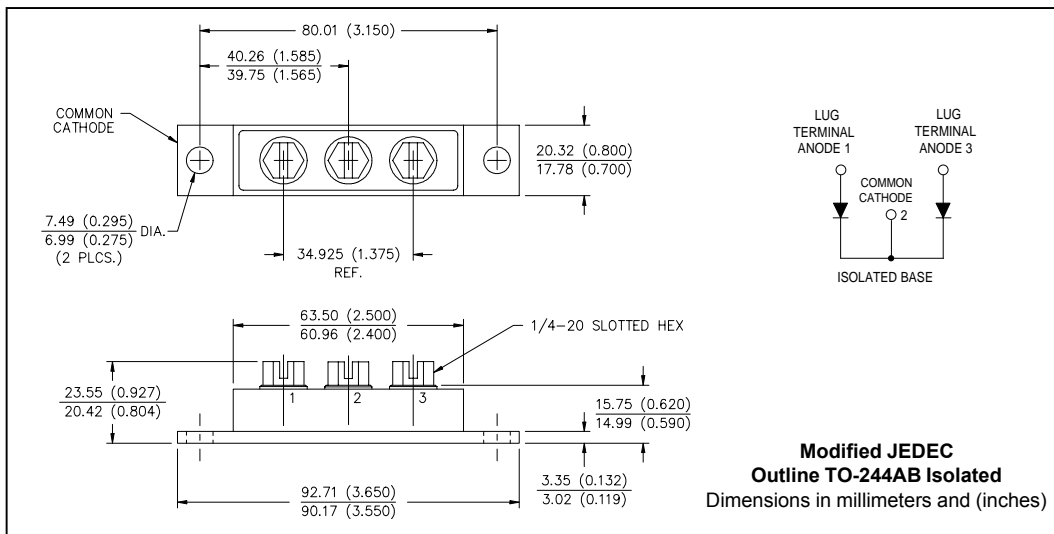

208CMQ060

Bulletin PD-20732 rev. A 08/01

 International
IR Rectifier

Voltage Ratings

| Part number | 208CMQ060 |
|---|-----------|
| V_R Max. DC Reverse Voltage (V) | 60 |
| V_{RWM} Max. Working Peak Reverse Voltage (V) | |

Absolute Maximum Ratings

| Parameters | 208CMQ | Units | Conditions |
|---|--------|-------|--|
| $I_{F(AV)}$ Max. Average Forward Current (Per Leg) * See Fig. 5 (Per Device) | 100 | A | 50% duty cycle @ $T_C = 90^\circ\text{C}$, rectangular wave form |
| | 200 | | |
| I_{FSM} Max. Peak One Cycle Non-Repetitive Surge Current (Per Leg) * See Fig. 7 | 16,000 | A | 5 μ s Sine or 3 μ s Rect. pulse 10ms Sine or 6ms Rect. pulse Following any rated load condition and with rated V_{RWM} applied |
| | 2,100 | | |
| E_{AS} Non-Repetitive Avalanche Energy (Per Leg) | 15 | mJ | $T_J = 25^\circ\text{C}$, $I_{AS} = 1$ Amps, $L = 30$ mH |
| I_{AR} Repetitive Avalanche Current (Per Leg) | 1 | A | Current decaying linearly to zero in 1 μ sec Frequency limited by T_J max. $V_A = 1.5 \times V_R$ typical |

Electrical Specifications

| Parameters | 208CMQ | Units | Conditions |
|--|--------|------------|---|
| V_{FM} Max. Forward Voltage Drop (Per Leg) * See Fig. 1 (1) | 0.68 | V | @ 100A $T_J = 25^\circ\text{C}$ |
| | 0.83 | V | @ 200A |
| | 0.59 | V | @ 100A $T_J = 125^\circ\text{C}$ |
| | 0.75 | V | @ 200A |
| I_{RM} Max. Reverse Leakage Current (Per Leg) * See Fig. 2 (1) | 1.1 | mA | $T_J = 25^\circ\text{C}$ |
| | 300 | mA | $T_J = 125^\circ\text{C}$ $V_R = \text{rated } V_R$ |
| $V_{F(TO)}$ Threshold Voltage | 0.32 | V | $T_J = T_J \text{ max.}$ |
| r_t Forward Slope Resistance | 2.1 | m Ω | |
| C_T Max. Junction Capacitance (Per Leg) | 6000 | pF | $V_R = 5V_{DC}$, (test signal range 100Khz to 1Mhz) 25°C |
| L_S Typical Series Inductance (Per Leg) | 7.0 | nH | From top of terminal hole to mounting plane |
| dv/dt Max. Voltage Rate of Change | 10000 | V/ μ s | (Rated V_R) |
| V_{RMS} Insulation Voltage | 1000 | V | |

 (1) Pulse Width < 300 μ s, Duty Cycle < 2%

Thermal-Mechanical Specifications

| Parameters | 208CMQ | Units | Conditions |
|---|-------------------|--------------------|--------------------------------------|
| T_J Max. Junction Temperature Range | -55 to 150 | $^\circ\text{C}$ | |
| T_{stg} Max. Storage Temperature Range | -55 to 150 | $^\circ\text{C}$ | |
| R_{thJC} Max. Thermal Resistance Junction to Case (Per Leg) | 0.70 | $^\circ\text{C/W}$ | DC operation * See Fig. 4 |
| R_{thJC} Max. Thermal Resistance Junction to Case (Per Package) | 0.35 | $^\circ\text{C/W}$ | DC operation |
| R_{thCS} Typical Thermal Resistance, Case to Heatsink | 0.10 | $^\circ\text{C/W}$ | Mounting surface, smooth and greased |
| wt Approximate Weight | 79 (2.80) | g (oz.) | |
| T Mounting Torque | Min. | 24 (20) | Kg-cm (lbf-in) |
| | Max. | 35 (30) | |
| | Typ. | 13.5 (12) | |
| | Min. | 35 (30) | |
| | Max. | 46 (40) | |
| Case Style | TO-244AB Isolated | | Modified JEDEC |

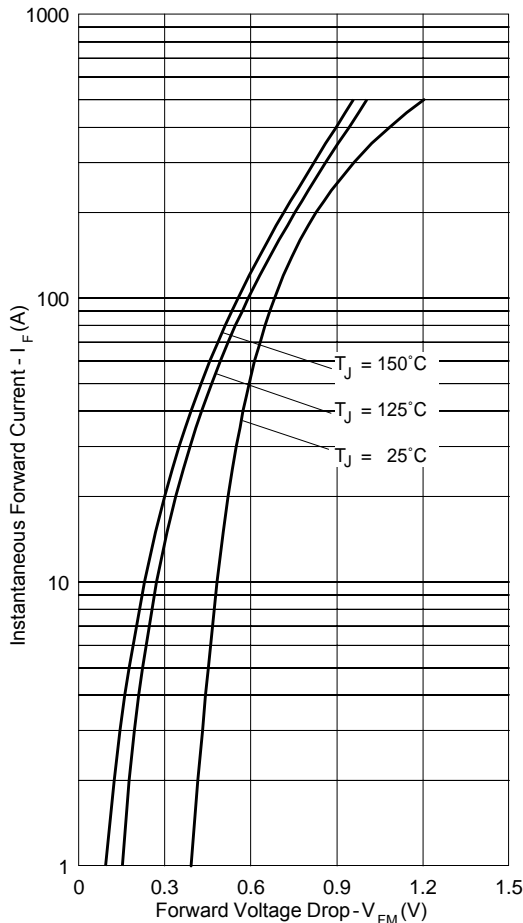

Fig. 1 - Max. Forward Voltage Drop Characteristics

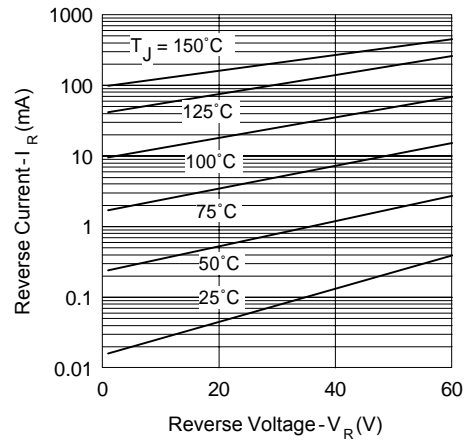

Fig. 2 - Typical Values Of Reverse Current Vs. Reverse Voltage

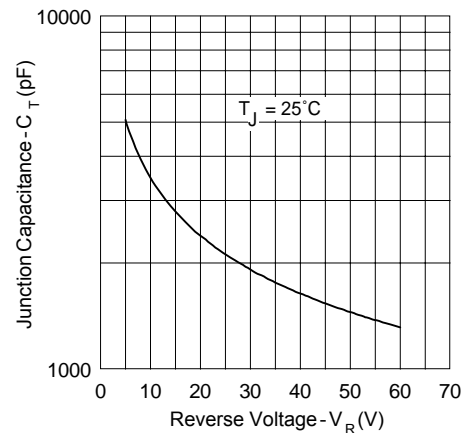

Fig. 3 - Typical Junction Capacitance Vs. Reverse Voltage

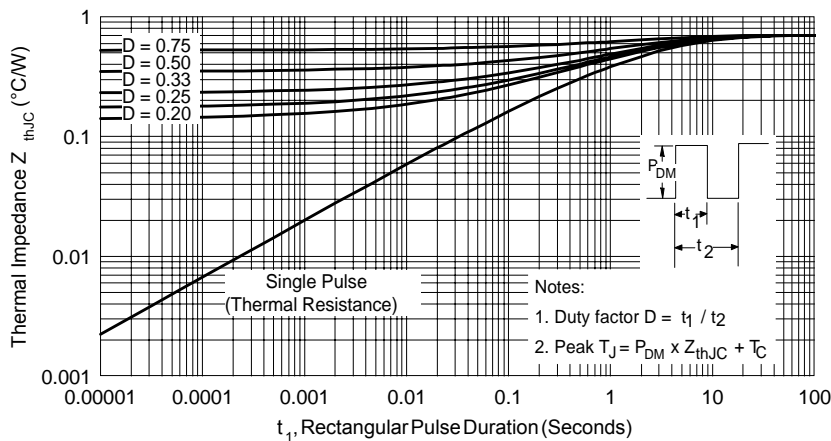

Fig. 4 - Max. Thermal Impedance Z_{thJC} Characteristics (Per Leg)

208CMQ060

Bulletin PD-20732 rev. A 08/01

International
IR Rectifier

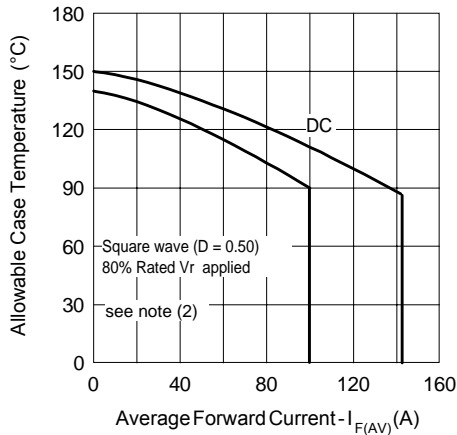

Fig. 5 - Max. Allowable Case Temperature Vs. Average Forward Current

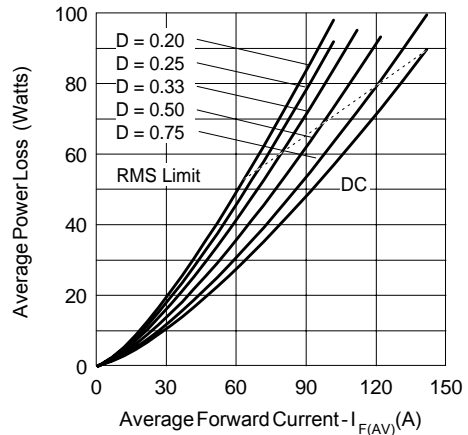

Fig. 6 - Forward Power Loss Characteristics

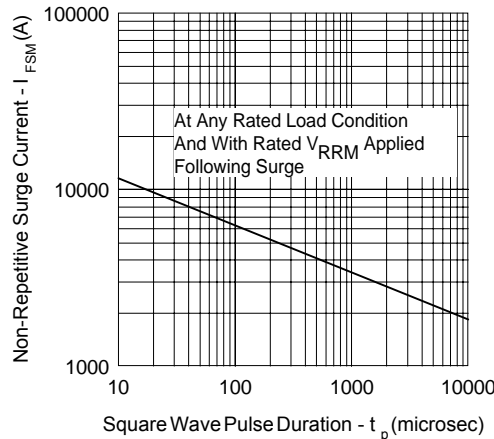

Fig. 7 - Max. Non-Repetitive Surge Current

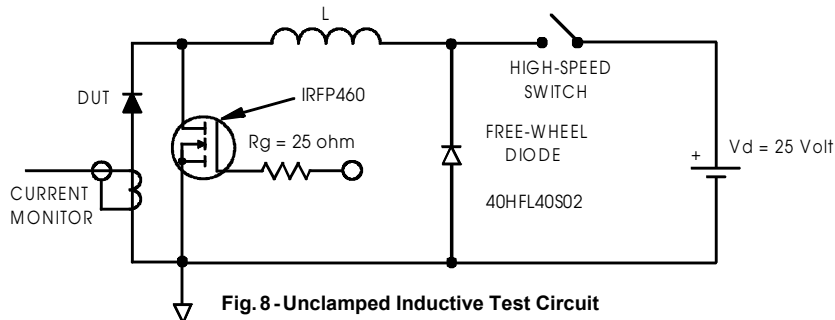

Fig. 8 - Unclamped Inductive Test Circuit

(2) Formula used: $T_C = T_J - (P_d + P_{d_{REV}}) \times R_{thJC}$
 $P_d = \text{Forward Power Loss} = I_{F(AV)} \times V_{FM} @ (I_{F(AV)} / D)$ (see Fig. 6);
 $P_{d_{REV}} = \text{Inverse Power Loss} = V_{R1} \times I_{R1} (1 - D)$; $I_{R1} @ V_{R1} = 80\% \text{ rated } V_R$

International
IOR Rectifier

208CMQ060

Bulletin PD-20732 rev. A 08/01

Ordering Information Table

| Device Code | | | | |
|-------------|----------|----------------------|----------|------------|
| 208 | C | M | Q | 060 |
| ① | ② | ③ | ④ | ⑤ |
| 1 | - | Current Rating: 200A | | |
| 2 | - | Common Cathode | | |
| 3 | - | Module | | |
| 4 | - | Schottky Q Series | | |
| 5 | - | Voltage Rating: 60V | | |

Data and specifications subject to change without notice.
 This product has been designed and qualified for Industrial Level.
 Qualification Standards can be found on IR's Web site.

International
IOR Rectifier

IR WORLD HEADQUARTERS: 233 Kansas St., El Segundo, California 90245, USA Tel: (310) 252-7105
 TAC Fax: (310) 252-7309

Visit us at www.irf.com for sales contact information. 08/01