

Excellent Integrated System Limited

Stocking Distributor

Click to view price, real time Inventory, Delivery & Lifecycle Information:

[Panduit](#)
[DHC1.12X1.75-D0](#)

For any questions, you can email us directly:
sales@integrated-circuit.com

THIS COPY IS PROVIDED ON A RESTRICTED BASIS AND IS NOT TO BE USED IN ANY WAY DETRIMENTAL TO THE INTERESTS OF PANDUIT CORP.

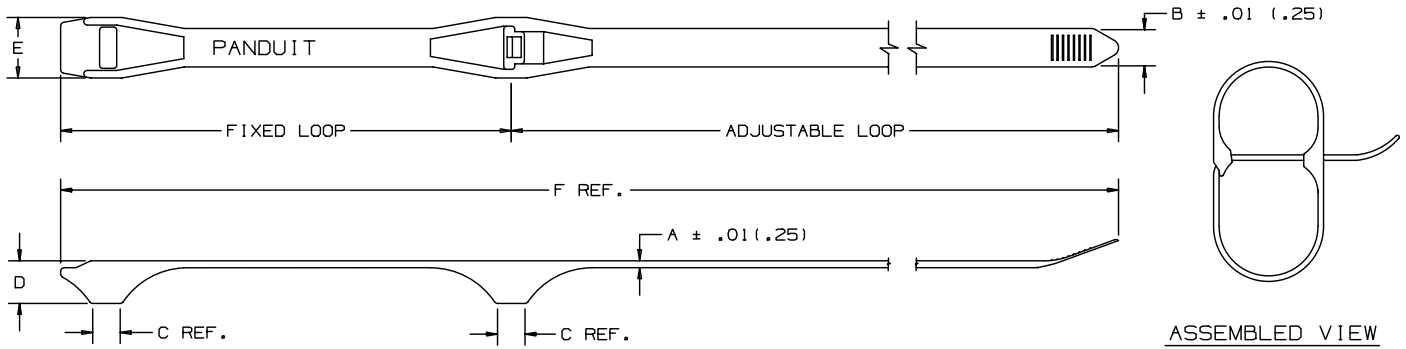

PANDUIT PART NUMBER*	LOOP DIAMETER		A in (mm)	B in (mm)	C in (mm)	D in (mm)	E in (mm)	F in (mm)	MIN. LOOP TENSILE lbs (N)	TIP STYLE	WEIGHT lbs / 100 (g) / PCS.	GS4H TOOL SETTING
	FIXED in (mm)	ADJUSTABLE in (mm)										
DHC1.12X 1.75	1.12 (28.4)	1.0 TO 1.75 (25.4 TO 44.45)	.050 (1.3)	.280 (7.1)	.23 (5.8)	.31 (7.9)	.44 (11.2)	11.0 (279)	100 (445)	CURVED	.75 (340)	4

NOTES:

- * 1. SEE CURRENT PRICE SHEET FOR PART NUMBER SUFFIX DESIGNATION FOR PACKAGE SIZE.
- 2. COLOR: BLACK

CAD FILENAME/LAYERS										
DIMENSIONS IN PARENTHESES ARE IN METRIC UNITS										
PANDUIT CORP. TINLEY PARK, ILLINOIS										
DOUBLE HOSE CLAMP-DHC1.12 X 1.75										
UNLESS OTHERWISE SPECIFIED, DIMENSIONAL TOLERANCES ARE: (.X) ± .1 (2.5) (.XXX) ± (.XX) ± .02 (1.5) ANGLES ±					UNLESS OTHERWISE SPECIFIED, ALL DIMENSIONS ARE GIVEN IN INCHES, THIRD ANGLE PROJECTION.					
DRAWN BY KET					MAT'L: NYLON 6/6 WEATHER RESISTANT					
DATE 6/2/95					SCALE NONE					
OK'D HVP					DRAWING NO. SS-6482					
DWG SIZE A										
5	12/23/03	JABO	CORRECTED METRIC CONVERSION OF ADJ. LOOP DIA			SS-6483	5			
REV	DATE	BY	CHK	DESCRIPTION			ECN - R	CUST	SUP	