

Excellent Integrated System Limited

Stocking Distributor

Click to view price, real time Inventory, Delivery & Lifecycle Information:

[Panduit](#)
[JP75SBC50R-L](#)

For any questions, you can email us directly:
sales@integrated-circuit.com

THIS COPY IS PROVIDED ON A RESTRICTED BASIS AND IS NOT TO BE USED IN ANY WAY DETRIMENTAL TO THE INTERESTS OF PANDUIT CORP.

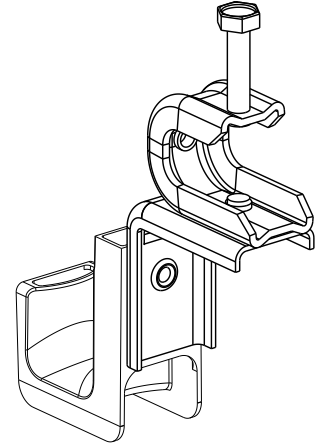
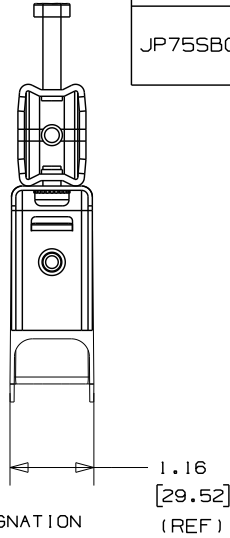
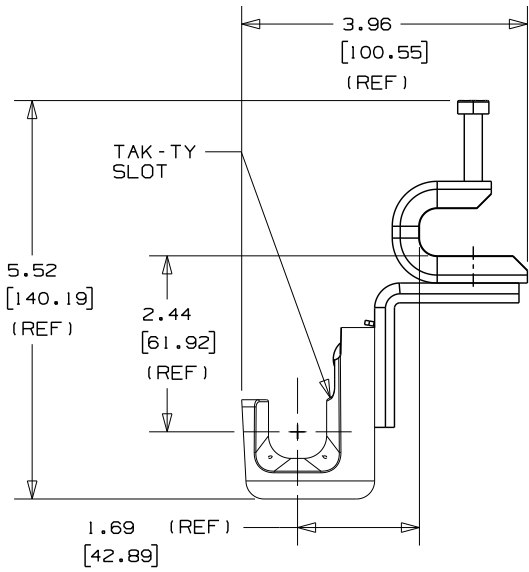

PANDUIT PART NO.	FLANGE THICKNESS	WEIGHT lbs 10 (g) pcs
JP75SBC50R-__	UP TO 0.50 (12.7)	2.63 (1192.95)

NOTES:

- SEE CURRENT PRICE SHEET FOR PART NUMBER SUFFIX DESIGNATION FOR PACKAGE SIZE AND PRODUCT COLOR.
- HOOK MATERIAL: NYLON 6/6
 ANGLE BRACKET MATERIAL: PRE-GALVANIZED STEEL
 RIVET MATERIAL: ALUMINUM
 BOLT MATERIAL: ZINC PLATED STEEL
 WASHER MATERIAL: ZINC PLATED STEEL
 CLAMP MATERIAL: PLATED STEEL
- PRODUCT IS DESIGNED TO SUPPORT A MAXIMUM OF 3/4" (19.05) DIAMETER BUNDLE. MAXIMUM RECOMMENDED STATIC LOAD: 15 lbs.
- PRODUCT INCORPORATES FEATURES ALLOWING USER TO RETAIN CABLE BUNDLES IN J-PRO J-HOOK WITH TAK-TY CABLE TIES UP TO 3/4" WIDE.
- PRODUCT MARKINGS:
 cULus logo and statement:
 "SUITABLE FOR USE IN AIR HANDLING SPACES IN ACCORDANCE WITH SECTION 300-22 (C) & (D) OF THE NATIONAL ELECTRIC CODE."
 ULC logo and statement:
 "IN ACCORDANCE WITH CAN/ULC S-102.2 IN SINGLE UNITS OR PAIRS, 4 ft (1220mm) MIN. SPACING, FSR=0, SDC=20."

DIMENSIONS IN BRACKETS ARE METRIC [mm]	
CAD FILENAME/LAYERS 10K016C1_DC_GB3043BG/01A	
PANDUIT CORP. TINLEY PARK, ILLINOIS	
J-PRO J-HOOK WITH 360° SCREW-ON BEAM CLAMP (JP75SBC50R-__)	
UNLESS OTHERWISE SPECIFIED, DIMENSIONAL TOLERANCES ARE: (.X) ±0.05 (1.3) (.XXX) ±0.010 (0.25) (.XX) ±0.02 (0.5) ANGLES ± 5°	UNLESS OTHERWISE SPECIFIED, ALL DIMENSIONS ARE GIVEN IN INCHES, THIRD ANGLE PROJECTION.
DRAWN BY JAD	MAT'L:
DATE 1/5/06	SEE NOTE 2
CHK'D KLN	SCALE NONE
	DWG NO. GB3043BG
	DBG SIZE A

REV	DATE	BY	CHK	DESCRIPTION	ECN	R	CUST	SUP	QC
O1A	11/9/10	ARHA	DJW	CHANGED FILENAME FORMAT	GB3043BG	O1A	KLN		
R	1/5/06	JAD		INITIAL RELEASE	GB3043BG	R			