

Excellent Integrated System Limited

Stocking Distributor

Click to view price, real time Inventory, Delivery & Lifecycle Information:

[NXP Semiconductors](#)
[MKE06Z128VLD4](#)

For any questions, you can email us directly:
sales@integrated-circuit.com

MKE06P80M48SF0



KE06 Sub-Family Data Sheet

Supports the following:

MKE06Z64VLD4(R),
 MKE06Z128VLD4(R),
 MKE06Z64VQH4(R),
 MKE06Z128VQH4(R),
 MKE06Z64VLH4(R),
 MKE06Z128VLH4(R),
 MKE06Z64VLK4(R), and
 MKE06Z128VLK4(R)

Key features

- Operating characteristics
 - Voltage range: 2.7 to 5.5 V
 - Flash write voltage range: 2.7 to 5.5 V
 - Temperature range (ambient): -40 to 105°C
- Performance
 - Up to 48 MHz ARM® Cortex-M0+ core
 - Single cycle 32-bit x 32-bit multiplier
 - Single cycle I/O access port
- Memories and memory interfaces
 - Up to 128 KB flash
 - Up to 16 KB RAM
- Clocks
 - Oscillator (OSC) - supports 32.768 kHz crystal or 4 MHz to 24 MHz crystal or ceramic resonator; choice of low power or high gain oscillators
 - Internal clock source (ICS) - internal FLL with internal or external reference, 37.5 kHz pre-trimmed internal reference for 48 MHz system clock
 - Internal 1 kHz low-power oscillator (LPO)
- System peripherals
 - Power management module (PMC) with three power modes: Run, Wait, Stop
 - Low-voltage detection (LVD) with reset or interrupt, selectable trip points
 - Watchdog with independent clock source (WDOG)
 - Programmable cyclic redundancy check module (CRC)
 - Serial wire debug interface (SWD)
 - Aliased SRAM bitband region (BIT-BAND)
 - Bit manipulation engine (BME)
- Security and integrity modules
 - 80-bit unique identification (ID) number per chip
- Human-machine interface
 - Up to 71 general-purpose input/output (GPIO)
 - Two 32-bit keyboard interrupt modules (KBI)
 - External interrupt (IRQ)
- Analog modules
 - One up to 16-channel 12-bit SAR ADC, operation in Stop mode, optional hardware trigger (ADC)
 - Two analog comparators containing a 6-bit DAC and programmable reference input (ACMP)
- Timers
 - One 6-channel FlexTimer/PWM (FTM)
 - Two 2-channel FlexTimer/PWM (FTM)
 - One 2-channel periodic interrupt timer (PIT)
 - One pulse width timer (PWT)
 - One real-time clock (RTC)

Freescale reserves the right to change the detail specifications as may be required to permit improvements in the design of its products.

© 2013–2014 Freescale Semiconductor, Inc.

- Communication interfaces
 - Two SPI modules (SPI)
 - Up to three UART modules (UART)
 - Two I2C modules (I2C)
 - One MSCAN module (MSCAN)
- Package options
 - 80-pin LQFP
 - 64-pin QFP/LQFP
 - 44-pin LQFP

Table of Contents

1 Ordering parts.....	4	5.2.2 FTM module timing.....	17
1.1 Determining valid orderable parts.....	4	5.3 Thermal specifications.....	18
2 Part identification.....	4	5.3.1 Thermal characteristics.....	18
2.1 Description.....	4	6 Peripheral operating requirements and behaviors.....	20
2.2 Format.....	4	6.1 Core modules.....	20
2.3 Fields.....	4	6.1.1 SWD electricals	20
2.4 Example.....	5	6.2 External oscillator (OSC) and ICS characteristics.....	21
3 Parameter classification.....	5	6.3 NVM specifications.....	23
4 Ratings.....	6	6.4 Analog.....	24
4.1 Thermal handling ratings.....	6	6.4.1 ADC characteristics.....	24
4.2 Moisture handling ratings.....	6	6.4.2 Analog comparator (ACMP) electricals.....	26
4.3 ESD handling ratings.....	6	6.5 Communication interfaces.....	27
4.4 Voltage and current operating ratings.....	7	6.5.1 SPI switching specifications.....	27
5 General.....	7	6.5.2 MSCAN.....	30
5.1 Nonswitching electrical specifications.....	7	7 Dimensions.....	30
5.1.1 DC characteristics.....	7	7.1 Obtaining package dimensions.....	30
5.1.2 Supply current characteristics.....	14	8 Pinout.....	31
5.1.3 EMC performance.....	15	8.1 Signal multiplexing and pin assignments.....	31
5.2 Switching specifications.....	16	8.2 Device pin assignment.....	33
5.2.1 Control timing.....	16	9 Revision history.....	36

1 Ordering parts

1.1 Determining valid orderable parts

Valid orderable part numbers are provided on the web. To determine the orderable part numbers for this device, go to freescale.com and perform a part number search for the following device numbers: KE06Z.

2 Part identification

2.1 Description

Part numbers for the chip have fields that identify the specific part. You can use the values of these fields to determine the specific part you have received.

2.2 Format

Part numbers for this device have the following format:

Q KE## A FFF R T PP CC N

2.3 Fields

This table lists the possible values for each field in the part number (not all combinations are valid):

Field	Description	Values
Q	Qualification status	<ul style="list-style-type: none"> M = Fully qualified, general market flow P = Prequalification
KE##	Kinetis family	<ul style="list-style-type: none"> KE06
A	Key attribute	<ul style="list-style-type: none"> Z = M0+ core
FFF	Program flash memory size	<ul style="list-style-type: none"> 128 = 128 KB
R	Silicon revision	<ul style="list-style-type: none"> (Blank) = Main A = Revision after main
T	Temperature range (°C)	<ul style="list-style-type: none"> V = -40 to 105
PP	Package identifier	<ul style="list-style-type: none"> LD = 44 LQFP (10 mm x 10 mm)

Table continues on the next page...

Parameter classification

Field	Description	Values
		<ul style="list-style-type: none"> QH = 64 QFP (14 mm x 14 mm) LH = 64 LQFP (10 mm x 10 mm) LK = 80 LQFP (14 mm x 14 mm)
CC	Maximum CPU frequency (MHz)	<ul style="list-style-type: none"> 4 = 48 MHz
N	Packaging type	<ul style="list-style-type: none"> R = Tape and reel (Blank) = Trays

2.4 Example

This is an example part number:

MKE06Z128VLK4

3 Parameter classification

The electrical parameters shown in this supplement are guaranteed by various methods. To give the customer a better understanding, the following classification is used and the parameters are tagged accordingly in the tables where appropriate:

Table 1. Parameter classifications

P	Those parameters are guaranteed during production testing on each individual device.
C	Those parameters are achieved by the design characterization by measuring a statistically relevant sample size across process variations.
T	Those parameters are achieved by design characterization on a small sample size from typical devices under typical conditions unless otherwise noted. All values shown in the typical column are within this category.
D	Those parameters are derived mainly from simulations.

NOTE

The classification is shown in the column labeled “C” in the parameter tables where appropriate.

4 Ratings

4.1 Thermal handling ratings

Symbol	Description	Min.	Max.	Unit	Notes
T _{STG}	Storage temperature	-55	150	°C	1
T _{SDR}	Solder temperature, lead-free	—	260	°C	2

1. Determined according to JEDEC Standard JESD22-A103, *High Temperature Storage Life*.
2. Determined according to IPC/JEDEC Standard J-STD-020, *Moisture/Reflow Sensitivity Classification for Nonhermetic Solid State Surface Mount Devices*.

4.2 Moisture handling ratings

Symbol	Description	Min.	Max.	Unit	Notes
MSL	Moisture sensitivity level	—	3	—	1

1. Determined according to IPC/JEDEC Standard J-STD-020, *Moisture/Reflow Sensitivity Classification for Nonhermetic Solid State Surface Mount Devices*.

4.3 ESD handling ratings

Symbol	Description	Min.	Max.	Unit	Notes
V _{HBM}	Electrostatic discharge voltage, human body model	-6000	+6000	V	1
V _{CDM}	Electrostatic discharge voltage, charged-device model	-500	+500	V	2
I _{LAT}	Latch-up current at ambient temperature of 125°C	-100	+100	mA	3

1. Determined according to JEDEC Standard JESD22-A114, *Electrostatic Discharge (ESD) Sensitivity Testing Human Body Model (HBM)*.
2. Determined according to JEDEC Standard JESD22-C101, *Field-Induced Charged-Device Model Test Method for Electrostatic-Discharge-Withstand Thresholds of Microelectronic Components*.
3. Determined according to JEDEC Standard JESD78D, *IC Latch-up Test*.
 - Test was performed at 125 °C case temperature (Class II).
 - I/O pins pass ±100 mA I-test with I_{DD} current limit at 400 mA.
 - I/O pins pass +50/-100 mA I-test with I_{DD} current limit at 1000 mA.
 - Supply groups pass 1.5 V_{CCmax}.
 - RESET pin was only tested with negative I-test due to product conditioning requirement.

4.4 Voltage and current operating ratings

Absolute maximum ratings are stress ratings only, and functional operation at the maxima is not guaranteed. Stress beyond the limits specified in the following table may affect device reliability or cause permanent damage to the device. For functional operating conditions, refer to the remaining tables in this document.

This device contains circuitry protecting against damage due to high static voltage or electrical fields; however, it is advised that normal precautions be taken to avoid application of any voltages higher than maximum-rated voltages to this high-impedance circuit. Reliability of operation is enhanced if unused inputs are tied to an appropriate logic voltage level (for instance, either V_{SS} or V_{DD}) or the programmable pullup resistor associated with the pin is enabled.

Table 2. Voltage and current operating ratings

Symbol	Description	Min.	Max.	Unit
V_{DD}	Digital supply voltage	-0.3	6.0	V
I_{DD}	Maximum current into V_{DD}	—	120	mA
V_{IN}	Input voltage except true open drain pins	-0.3	$V_{DD} + 0.3^1$	V
	Input voltage of true open drain pins	-0.3	6	V
I_D	Instantaneous maximum current single pin limit (applies to all port pins)	-25	25	mA
V_{DDA}	Analog supply voltage	$V_{DD} - 0.3$	$V_{DD} + 0.3$	V

1. Maximum rating of V_{DD} also applies to V_{IN} .

5 General

5.1 Nonswitching electrical specifications

5.1.1 DC characteristics

This section includes information about power supply requirements and I/O pin characteristics.

Table 3. DC characteristics

Symbol	C	Descriptions		Min	Typical ¹	Max	Unit
—	—	Operating voltage	—	2.7	—	5.5	V

Table continues on the next page...

nonswitching electrical specifications

Table 3. DC characteristics (continued)

Symbol	C	Descriptions		Min	Typical ¹	Max	Unit	
V _{OH}	P	Output high voltage	All I/O pins, except PTA2 and PTA3, standard-drive strength	5 V, I _{load} = -5 mA	V _{DD} - 0.8	—	—	V
	C			3 V, I _{load} = -2.5 mA	V _{DD} - 0.8	—	—	V
	P	High current drive pins, high-drive strength ²	5 V, I _{load} = -20 mA	V _{DD} - 0.8	—	—	V	
	C		3 V, I _{load} = -10 mA	V _{DD} - 0.8	—	—	V	
I _{OHT}	D	Output high current	Max total I _{OH} for all ports	5 V	—	—	-100	mA
				3 V	—	—	-60	
V _{OL}	P	Output low voltage	All I/O pins, standard-drive strength	5 V, I _{load} = 5 mA	—	—	0.8	V
	C			3 V, I _{load} = 2.5 mA	—	—	0.8	V
	P	High current drive pins, high-drive strength ²	5 V, I _{load} = 20 mA	—	—	0.8	V	
	C		3 V, I _{load} = 10 mA	—	—	0.8	V	
I _{OLT}	D	Output low current	Max total I _{OL} for all ports	5 V	—	—	100	mA
				3 V	—	—	60	
V _{IH}	P	Input high voltage	All digital inputs	4.5 ≤ V _{DD} < 5.5 V	0.65 × V _{DD}	—	—	V
				2.7 ≤ V _{DD} < 4.5 V	0.70 × V _{DD}	—	—	
V _{IL}	P	Input low voltage	All digital inputs	4.5 ≤ V _{DD} < 5.5 V	—	—	0.35 × V _{DD}	V
				2.7 ≤ V _{DD} < 4.5 V	—	—	0.30 × V _{DD}	
V _{hys}	C	Input hysteresis	All digital inputs	—	0.06 × V _{DD}	—	—	mV
I _{Inl}	P	Input leakage current	Per pin (pins in high impedance input mode)	V _{IN} = V _{DD} or V _{SS}	—	0.1	1	μA
I _{INTOTl}	C	Total leakage combined for all port pins	Pins in high impedance input mode	V _{IN} = V _{DD} or V _{SS}	—	—	2	μA
R _{PU}	P	Pullup resistors	All digital inputs, when enabled (all I/O pins other than PTA2 and PTA3)	—	30.0	—	50.0	kΩ
R _{PU} ³	P	Pullup resistors	PTA2 and PTA3 pins	—	30.0	—	60.0	kΩ
I _{IC}	D	DC injection current ^{4, 5, 6}	Single pin limit	V _{IN} < V _{SS} , V _{IN} > V _{DD}	-2	—	2	mA
			Total MCU limit, includes sum of all stressed pins		-5	—	25	
C _{In}	C	Input capacitance, all pins		—	—	—	7	pF
V _{RAM}	C	RAM retention voltage		—	2.0	—	—	V

1. Typical values are measured at 25 °C. Characterized, not tested.

Nonswitching electrical specifications

- Only PTB4, PTB5, PTD0, PTD1, PTE0, PTE1, PTH0 (64-pin and 80-pin packages only), and PTH1 (64-pin and 80-pin packages only) support high current output.
- The specified resistor value is the actual value internal to the device. The pullup value may appear higher when measured externally on the pin.
- All functional non-supply pins, except for PTA2 and PTA3, are internally clamped to V_{SS} and V_{DD} . PTA2 and PTA3 are true open drain I/O pins that are internally clamped to V_{SS} .
- Input must be current limited to the value specified. To determine the value of the required current-limiting resistor, calculate resistance values for positive and negative clamp voltages, then use the larger value.
- Power supply must maintain regulation within operating V_{DD} range during instantaneous and operating maximum current conditions. If the positive injection current ($V_{IN} > V_{DD}$) is higher than I_{DD} , the injection current may flow out of V_{DD} and could result in external power supply going out of regulation. Ensure that external V_{DD} load will shunt current higher than maximum injection current when the MCU is not consuming power, such as when no system clock is present, or clock rate is very low (which would reduce overall power consumption).

Table 4. LVD and POR specification

Symbol	C	Description	Min	Typ	Max	Unit	
V_{POR}	D	POR re-arm voltage ¹	1.5	1.75	2.0	V	
V_{LVDH}	C	Falling low-voltage detect threshold—high range (LVDV = 1) ²	4.2	4.3	4.4	V	
V_{LVW1H}	C	Falling low-voltage warning threshold—high range	Level 1 falling (LVWV = 00)	4.3	4.4	4.5	V
V_{LVW2H}	C		Level 2 falling (LVWV = 01)	4.5	4.5	4.6	V
V_{LVW3H}	C		Level 3 falling (LVWV = 10)	4.6	4.6	4.7	V
V_{LVW4H}	C		Level 4 falling (LVWV = 11)	4.7	4.7	4.8	V
V_{HYSH}	C	High range low-voltage detect/warning hysteresis	—	100	—	mV	
V_{LVDL}	C	Falling low-voltage detect threshold—low range (LVDV = 0)	2.56	2.61	2.66	V	
V_{LVW1L}	C	Falling low-voltage warning threshold—low range	Level 1 falling (LVWV = 00)	2.62	2.7	2.78	V
V_{LVW2L}	C		Level 2 falling (LVWV = 01)	2.72	2.8	2.88	V
V_{LVW3L}	C		Level 3 falling (LVWV = 10)	2.82	2.9	2.98	V
V_{LVW4L}	C		Level 4 falling (LVWV = 11)	2.92	3.0	3.08	V
V_{HYSDL}	C	Low range low-voltage detect hysteresis	—	40	—	mV	
V_{HYSWL}	C	Low range low-voltage warning hysteresis	—	80	—	mV	
V_{BG}	P	Buffered bandgap output ³	1.14	1.16	1.18	V	

- Maximum is highest voltage that POR is guaranteed.
- Rising thresholds are falling threshold + hysteresis.
- voltage Factory trimmed at $V_{DD} = 5.0$ V, Temp = 25 °C

nonswitching electrical specifications

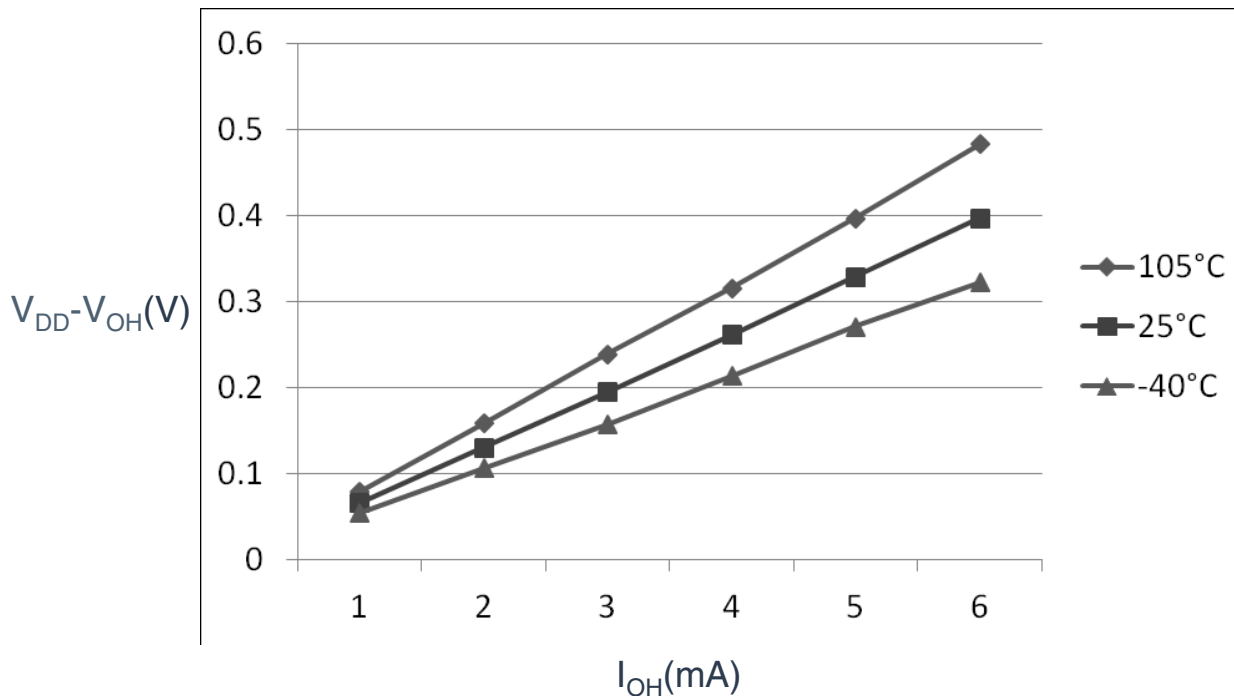

Figure 1. Typical $V_{DD}-V_{OH}$ Vs. I_{OH} (standard drive strength) ($V_{DD} = 5V$)

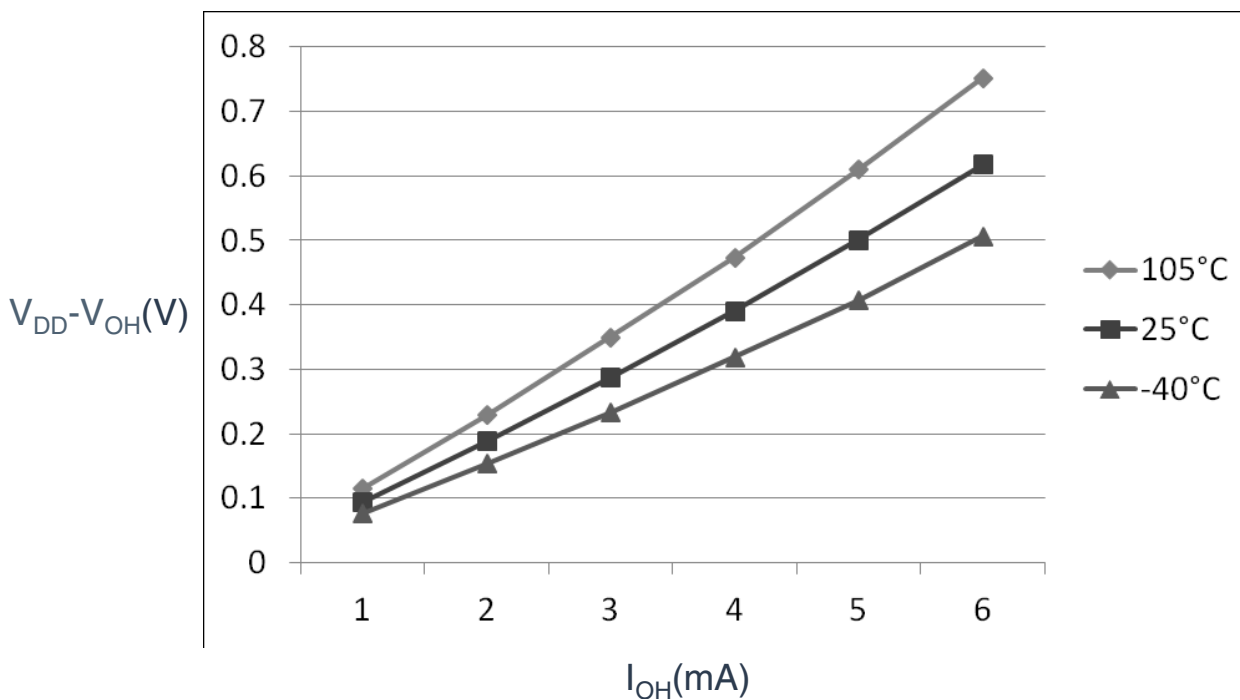

Figure 2. Typical $V_{DD}-V_{OH}$ Vs. I_{OH} (standard drive strength) ($V_{DD} = 3V$)

Nonswitching electrical specifications

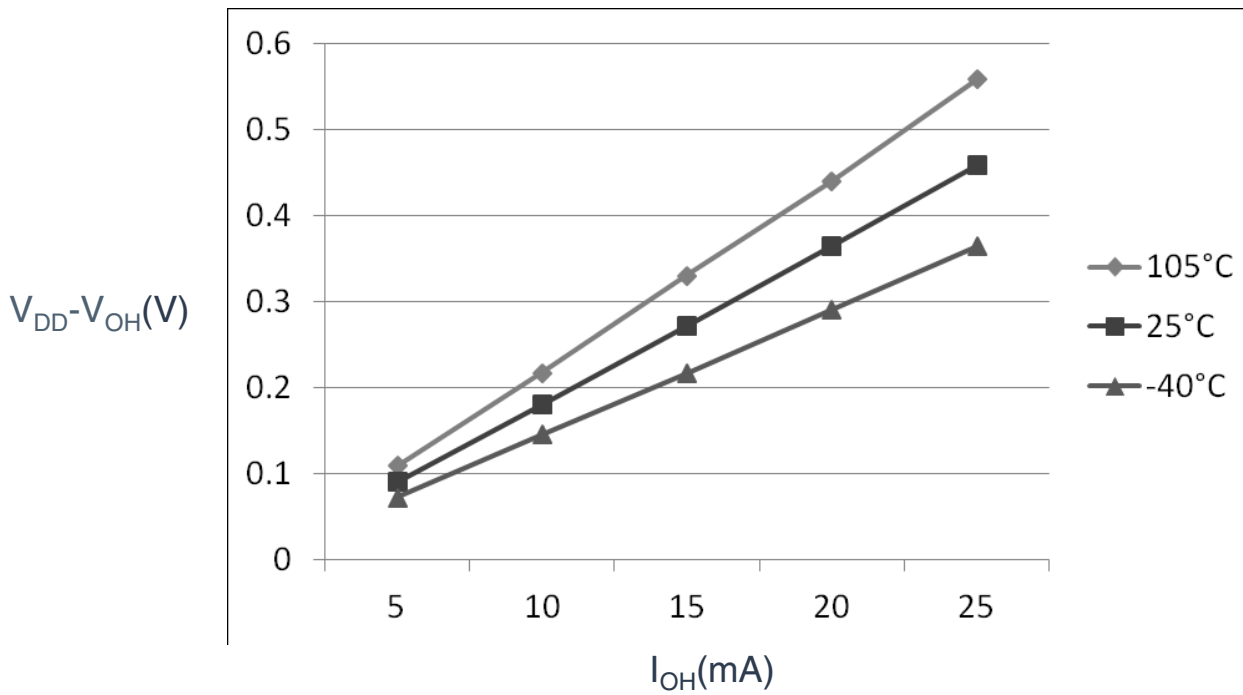

Figure 3. Typical $V_{DD}-V_{OH}$ Vs. I_{OH} (high drive strength) ($V_{DD} = 5V$)

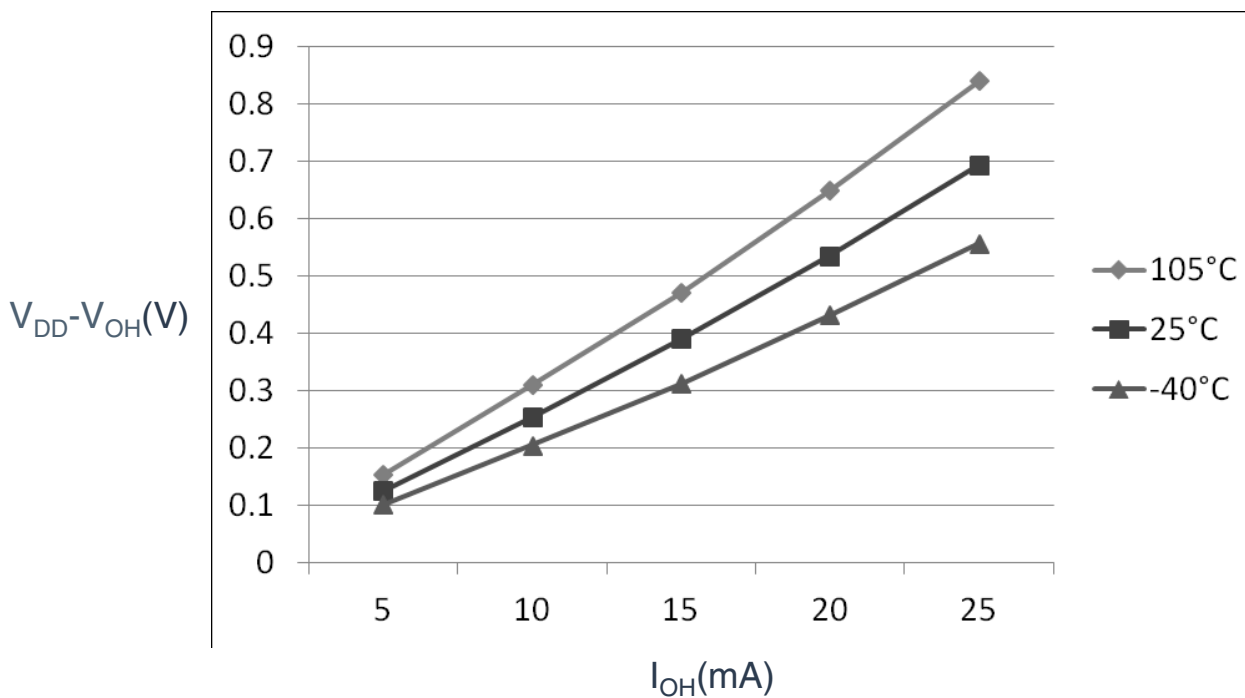

Figure 4. Typical $V_{DD}-V_{OH}$ Vs. I_{OH} (high drive strength) ($V_{DD} = 3V$)

nonswitching electrical specifications

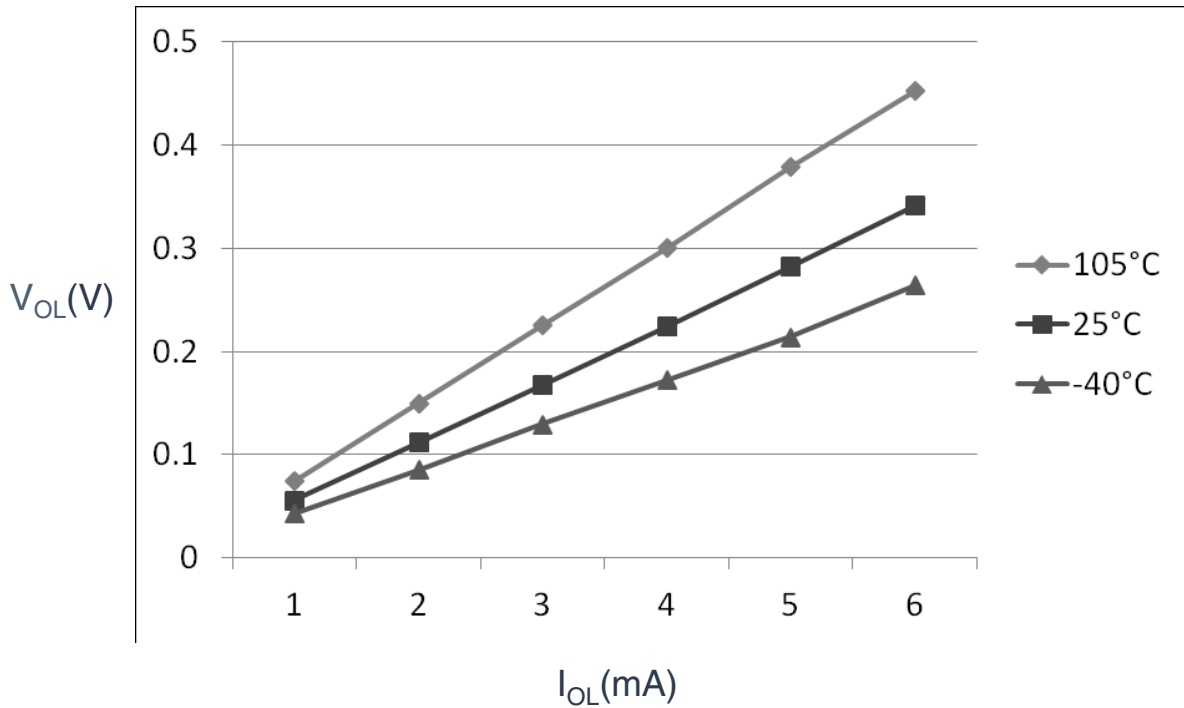

Figure 5. Typical V_{OL} Vs. I_{OL} (standard drive strength) ($V_{DD} = 5V$)

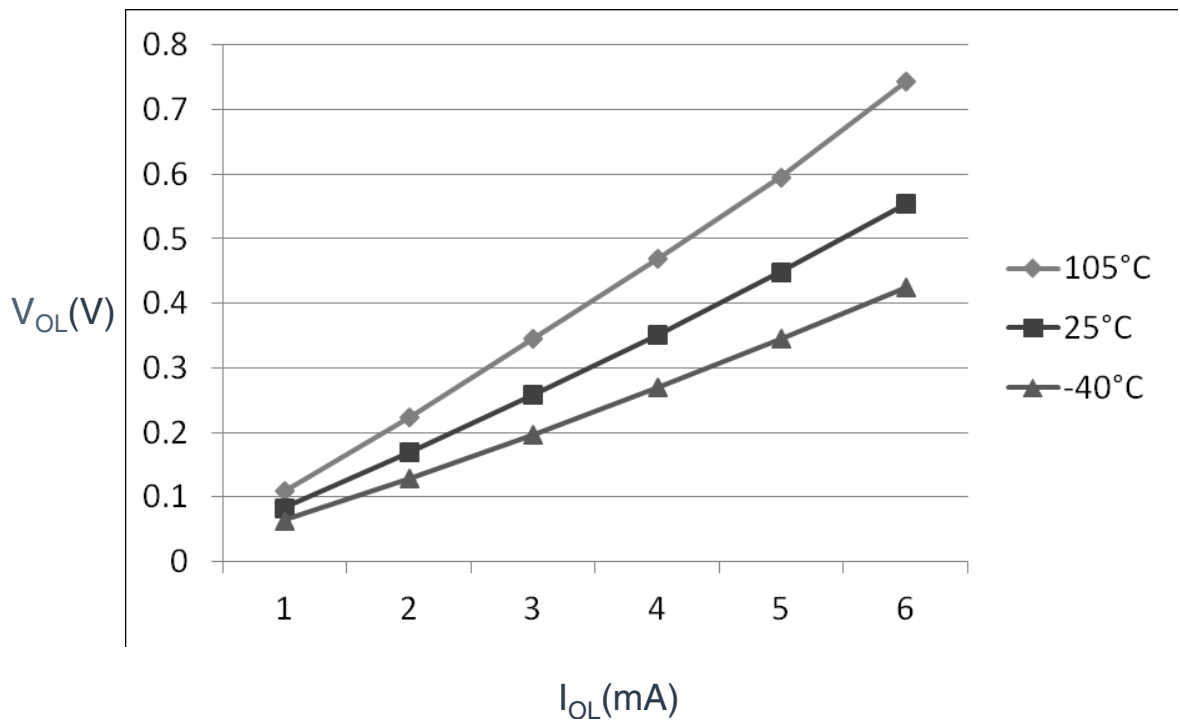

Figure 6. Typical V_{OL} Vs. I_{OL} (standard drive strength) ($V_{DD} = 3V$)

Nonswitching electrical specifications

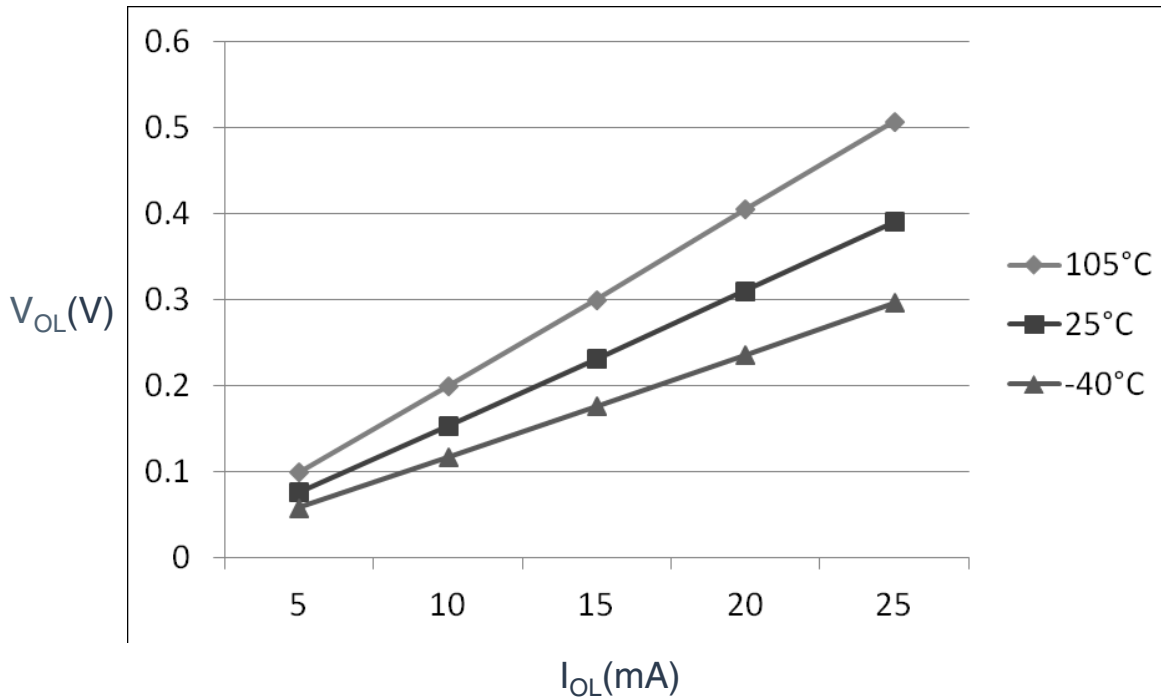

Figure 7. Typical V_{OL} Vs. I_{OL} (high drive strength) (V_{DD} = 5 V)

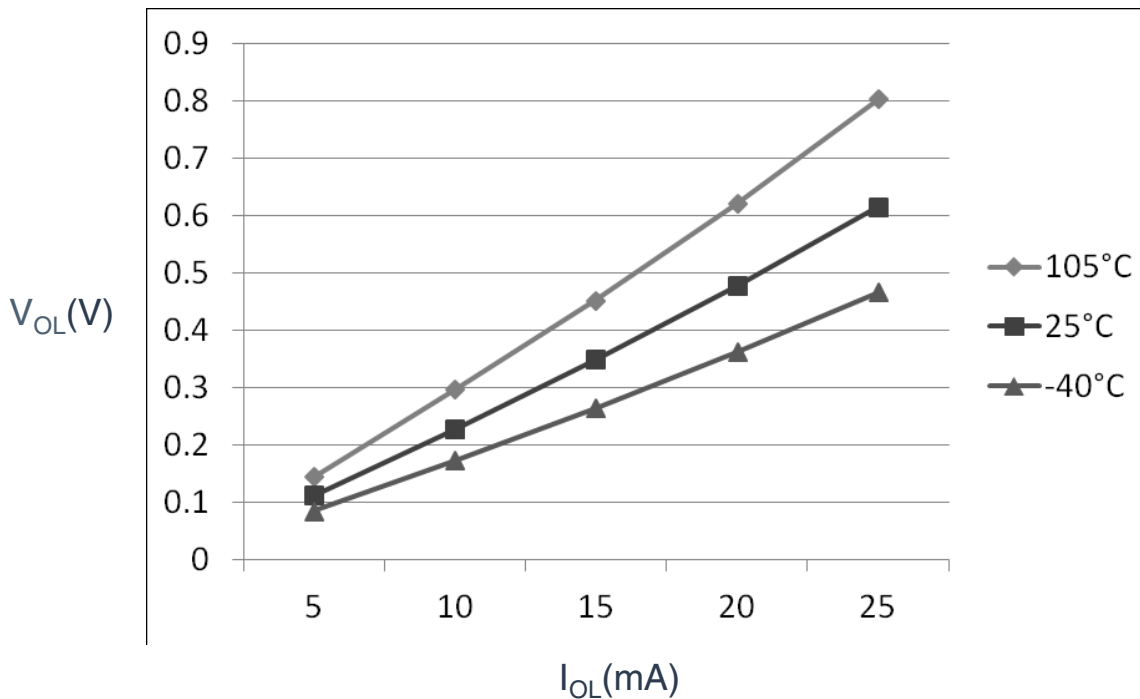

Figure 8. Typical V_{OL} Vs. I_{OL} (high drive strength) (V_{DD} = 3 V)

nonswitching electrical specifications

5.1.2 Supply current characteristics

This section includes information about power supply current in various operating modes.

Table 5. Supply current characteristics

C	Parameter	Symbol	Core/Bus Freq	V _{DD} (V)	Typical ¹	Max ²	Unit	Temp
C	Run supply current FEI mode, all modules clocks enabled; run from flash	R _{IDD}	48/24 MHz	5	11.1	—	mA	-40 to 105 °C
C			24/24 MHz		8	—		
C			12/12 MHz		5	—		
C			1/1 MHz		2.4	—		
C			48/24 MHz	3	11	—		
C			24/24 MHz		7.9	—		
C			12/12 MHz		4.9	—		
C			1/1 MHz		2.3	—		
C	Run supply current FEI mode, all modules clocks disabled and gated; run from flash	R _{IDD}	48/24 MHz	5	7.8	—	mA	-40 to 105 °C
C			24/24 MHz		5.5	—		
C			12/12 MHz		3.8	—		
C			1/1 MHz		2.3	—		
C			48/24 MHz	3	7.7	—		
C			24/24 MHz		5.4	—		
C			12/12 MHz		3.7	—		
C			1/1 MHz		2.2	—		
C	Run supply current FBE mode, all modules clocks enabled; run from RAM	R _{IDD}	48/24 MHz	5	14.7	—	mA	-40 to 105 °C
P			24/24 MHz		9.8	14.9		
C			12/12 MHz		6	—		
C			1/1 MHz		2.4	—		
C			48/24 MHz	3	14.6	—		
P			24/24 MHz		9.6	12.8		
C			12/12 MHz		5.9	—		
C			1/1 MHz		2.3	—		
C	Run supply current FBE mode, all modules clocks disabled and gated; run from RAM	R _{IDD}	48/24 MHz	5	11.4	—	mA	-40 to 105 °C
P			24/24 MHz		7.7	12.5		
C			12/12 MHz		4.7	—		
C			1/1 MHz		2.3	—		
C			48/24 MHz	3	11.3	—		
P			24/24 MHz		7.6	9.5		
C			12/12 MHz		4.6	—		
C			1/1 MHz		2.2	—		

Table continues on the next page...

Nonswitching electrical specifications

Table 5. Supply current characteristics (continued)

C	Parameter	Symbol	Core/Bus Freq	V _{DD} (V)	Typical ¹	Max ²	Unit	Temp
C	Wait mode current FEI mode, all modules clocks enabled	W _{DD}	48/24 MHz	5	8.4	—	mA	-40 to 105 °C
P			24/24 MHz		6.5	7.2		
C			12/12 MHz		4.3	—		
C			1/1 MHz		2.4	—		
C			48/24 MHz	3	8.3	—		
P			24/24 MHz		6.4	7		
C			12/12 MHz		4.2	—		
C			1/1 MHz		2.3	—		
P	Stop mode supply current no clocks active (except 1 kHz LPO clock) ³	S _{DD}	—	5	2	105	μA	-40 to 105 °C
P			—	3	1.9	95		-40 to 105 °C
C	ADC adder to Stop	—	—	5	86	—	μA	-40 to 105 °C
C	ADLPC = 1 ADLSMP = 1 ADCO = 1 MODE = 10B ADICLK = 11B	—	—	3	82	—		
C	ACMP adder to Stop	—	—	5	12	—	μA	-40 to 105 °C
C				3	12	—		
C	LVD adder to Stop ⁴	—	—	5	130	—	μA	-40 to 105 °C
C				3	125	—		

1. Data in Typical column was characterized at 5.0 V, 25 °C or is typical recommended value.
2. The Max current is observed at high temperature of 105 °C.
3. RTC adder cause <1 μA I_{DD} increase typically, RTC clock source is 1 kHz LPO clock.
4. LVD is periodically woken up from Stop by 5% duty cycle. The period is equal to or less than 2 ms.

5.1.3 EMC performance

Electromagnetic compatibility (EMC) performance is highly dependent on the environment in which the MCU resides. Board design and layout, circuit topology choices, location and characteristics of external components as well as MCU software operation play a significant role in EMC performance. The system designer must consult the following Freescale applications notes, available on freescale.com for advice and guidance specifically targeted at optimizing EMC performance.

- AN2321: Designing for Board Level Electromagnetic Compatibility
- AN1050: Designing for Electromagnetic Compatibility (EMC) with HCMOS Microcontrollers
- AN1263: Designing for Electromagnetic Compatibility with Single-Chip Microcontrollers

Switching specifications

- AN2764: Improving the Transient Immunity Performance of Microcontroller-Based Applications
- AN1259: System Design and Layout Techniques for Noise Reduction in MCU-Based Systems

5.1.3.1 EMC radiated emissions operating behaviors

Table 6. EMC radiated emissions operating behaviors for 80-pin LQFP package

Symbol	Description	Frequency band (MHz)	Typ.	Unit	Notes
V _{RE1}	Radiated emissions voltage, band 1	0.15–50	6	dBμV	1, 2
V _{RE2}	Radiated emissions voltage, band 2	50–150	6	dBμV	
V _{RE3}	Radiated emissions voltage, band 3	150–500	11	dBμV	
V _{RE4}	Radiated emissions voltage, band 4	500–1000	5	dBμV	
V _{RE_IEC}	IEC level	0.15–1000	N ³	—	2, 4

1. Determined according to IEC Standard 61967-1, *Integrated Circuits - Measurement of Electromagnetic Emissions, 150 kHz to 1 GHz Part 1: General Conditions and Definitions* and IEC Standard 61967-2, *Integrated Circuits - Measurement of Electromagnetic Emissions, 150 kHz to 1 GHz Part 2: Measurement of Radiated Emissions—TEM Cell and Wideband TEM Cell Method*. Measurements were made while the microcontroller was running basic application code. The reported emission level is the value of the maximum measured emission, rounded up to the next whole number, from among the measured orientations in each frequency range.
2. V_{DD} = 5.0 V, T_A = 25 °C, f_{OSC} = 8 MHz (crystal), f_{SYS} = 40 MHz, f_{BUS} = 20 MHz
3. IEC/SAE Level Maximums: N≤12 dBμV, M≤18 dBμV, K≤30 dBμV, I≤36 dBμV, H≤42 dBμV.
4. Specified according to Annex D of IEC Standard 61967-2, *Measurement of Radiated Emissions—TEM Cell and Wideband TEM Cell Method*

5.2 Switching specifications

5.2.1 Control timing

Table 7. Control timing

Num	C	Rating	Symbol	Min	Typical ¹	Max	Unit
1	D	System and core clock	f _{sys}	DC	—	48	MHz
2	P	Bus frequency (t _{cyc} = 1/f _{Bus})	f _{Bus}	DC	—	24	MHz
3	P	Internal low power oscillator frequency	f _{LPO}	0.67	1.0	1.25	KHz
4	D	External reset pulse width ²	t _{extrst}	1.5 × t _{cyc}	—	—	ns
5	D	Reset low drive	t _{rstdrv}	34 × t _{cyc}	—	—	ns
6	D	IRQ pulse width	Asynchronous path ²	t _{LIH}	100	—	ns
	D		Synchronous path ³	t _{HIH}	1.5 × t _{cyc}	—	ns

Table continues on the next page...

Table 7. Control timing (continued)

Num	C	Rating	Symbol	Min	Typical ¹	Max	Unit
7	D	Keyboard interrupt pulse width	Asynchronous path ²	t_{LH}	100	—	ns
	D		Synchronous path	t_{HIL}	$1.5 \times t_{cyc}$	—	ns
8	C	Port rise and fall time - Normal drive strength (load = 50 pF) ⁴	—	t_{Rise}	—	10.2	ns
	C		—	t_{Fall}	—	9.5	ns
	C	Port rise and fall time - high drive strength (load = 50 pF) ⁴	—	t_{Rise}	—	5.4	ns
	C		—	t_{Fall}	—	4.6	ns

1. Typical values are based on characterization data at $V_{DD} = 5.0\text{ V}$, $25\text{ }^\circ\text{C}$ unless otherwise stated.
2. This is the shortest pulse that is guaranteed to be recognized as a RESET pin request.
3. This is the minimum pulse width that is guaranteed to pass through the pin synchronization circuitry. Shorter pulses may or may not be recognized. In stop mode, the synchronizer is bypassed so shorter pulses can be recognized.
4. Timing is shown with respect to 20% V_{DD} and 80% V_{DD} levels. Temperature range $-40\text{ }^\circ\text{C}$ to $105\text{ }^\circ\text{C}$.

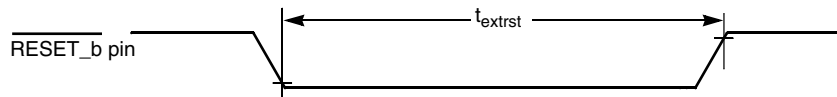

Figure 9. Reset timing

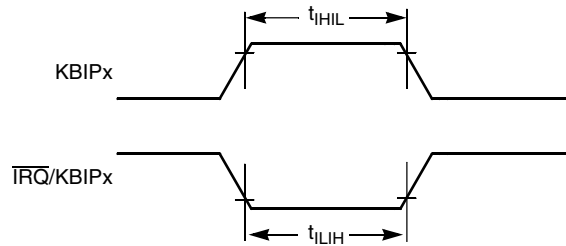

Figure 10. KBIPx timing

5.2.2 FTM module timing

Synchronizer circuits determine the shortest input pulses that can be recognized or the fastest clock that can be used as the optional external source to the timer counter. These synchronizers operate from the current bus rate clock.

Table 8. FTM input timing

C	Function	Symbol	Min	Max	Unit
D	Timer clock frequency	f_{Timer}	f_{Bus}	f_{Sys}	Hz
D	External clock frequency	f_{TCLK}	0	$f_{Timer}/4$	Hz

Table continues on the next page...

Thermal specifications

Table 8. FTM input timing (continued)

C	Function	Symbol	Min	Max	Unit
D	External clock period	t_{TCLK}	4	—	t_{Timer}^1
D	External clock high time	t_{clkh}	1.5	—	t_{Timer}^1
D	External clock low time	t_{clkl}	1.5	—	t_{Timer}^1
D	Input capture pulse width	t_{ICPW}	1.5	—	t_{Timer}^1

1. $t_{Timer} = 1/f_{Timer}$

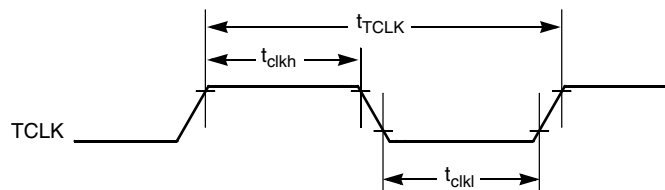

Figure 11. Timer external clock

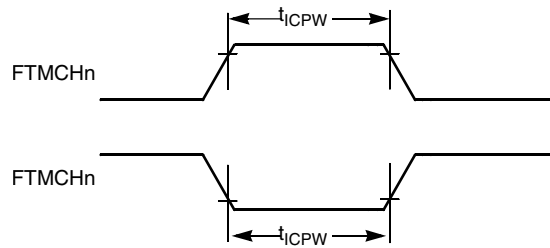

Figure 12. Timer input capture pulse

5.3 Thermal specifications

5.3.1 Thermal characteristics

This section provides information about operating temperature range, power dissipation, and package thermal resistance. Power dissipation on I/O pins is usually small compared to the power dissipation in on-chip logic and voltage regulator circuits, and it is user-determined rather than being controlled by the MCU design. To take $P_{I/O}$ into account in power calculations, determine the difference between actual pin voltage and V_{SS} or V_{DD} and multiply by the pin current for each I/O pin. Except in cases of unusually high pin current (heavy loads), the difference between pin voltage and V_{SS} or V_{DD} will be very small.

Table 9. Thermal attributes

Board type	Symbol	Description	64 LQFP	64 QFP	44 LQFP	80 LQFP	Unit	Notes
Single-layer (1S)	R _{θJA}	Thermal resistance, junction to ambient (natural convection)	71	61	75	57	°C/W	1, 2
Four-layer (2s2p)	R _{θJA}	Thermal resistance, junction to ambient (natural convection)	53	47	53	44	°C/W	1, 3
Single-layer (1S)	R _{θJMA}	Thermal resistance, junction to ambient (200 ft./min. air speed)	59	50	62	47	°C/W	1, 3
Four-layer (2s2p)	R _{θJMA}	Thermal resistance, junction to ambient (200 ft./min. air speed)	46	41	47	38	°C/W	1, 3
—	R _{θJB}	Thermal resistance, junction to board	35	32	34	28	°C/W	4
—	R _{θJC}	Thermal resistance, junction to case	20	23	20	15	°C/W	5
—	Ψ _{JT}	Thermal characterization parameter, junction to package top outside center (natural convection)	5	8	5	3	°C/W	6

1. Junction temperature is a function of die size, on-chip power dissipation, package thermal resistance, mounting site (board) temperature, ambient temperature, air flow, power dissipation of other components on the board, and board thermal resistance.
2. Per JEDEC JESD51-2 with the single layer board (JESD51-3) horizontal.
3. Per JEDEC JESD51-6 with the board (JESD51-7) horizontal.
4. Thermal resistance between the die and the printed circuit board per JEDEC JESD51-8. Board temperature is measured on the top surface of the board near the package.
5. Thermal resistance between the die and the solder pad on the bottom of the package. Interface resistance is ignored.
6. Thermal characterization parameter indicating the temperature difference between package top and the junction temperature per JEDEC JESD51-2. When Greek letters are not available, the thermal characterization.

The average chip-junction temperature (T_J) in °C can be obtained from:

$$T_J = T_A + (P_D \times \theta_{JA})$$

Where:

T_A = Ambient temperature, °C

θ_{JA} = Package thermal resistance, junction-to-ambient, °C/W

P_D = P_{int} + P_{I/O}

P_{int} = I_{DD} × V_{DD}, Watts - chip internal power

P_{I/O} = Power dissipation on input and output pins - user determined

For most applications, P_{I/O} << P_{int} and can be neglected. An approximate relationship between P_D and T_J (if P_{I/O} is neglected) is:

Peripheral operating requirements and behaviors

$$P_D = K \div (T_J + 273 \text{ }^\circ\text{C})$$

Solving the equations above for K gives:

$$K = P_D \times (T_A + 273 \text{ }^\circ\text{C}) + \theta_{JA} \times (P_D)^2$$

where K is a constant pertaining to the particular part. K can be determined by measuring P_D (at equilibrium) for an known T_A . Using this value of K, the values of P_D and T_J can be obtained by solving the above equations iteratively for any value of T_A .

6 Peripheral operating requirements and behaviors

6.1 Core modules

6.1.1 SWD electricals

Table 10. SWD full voltage range electricals

Symbol	Description	Min.	Max.	Unit
	Operating voltage	2.7	5.5	V
J1	SWD_CLK frequency of operation • Serial wire debug	0	24	MHz
J2	SWD_CLK cycle period	1/J1	—	ns
J3	SWD_CLK clock pulse width • Serial wire debug	20	—	ns
J4	SWD_CLK rise and fall times	—	3	ns
J9	SWD_DIO input data setup time to SWD_CLK rise	10	—	ns
J10	SWD_DIO input data hold time after SWD_CLK rise	3	—	ns
J11	SWD_CLK high to SWD_DIO data valid	—	35	ns
J12	SWD_CLK high to SWD_DIO high-Z	5	—	ns

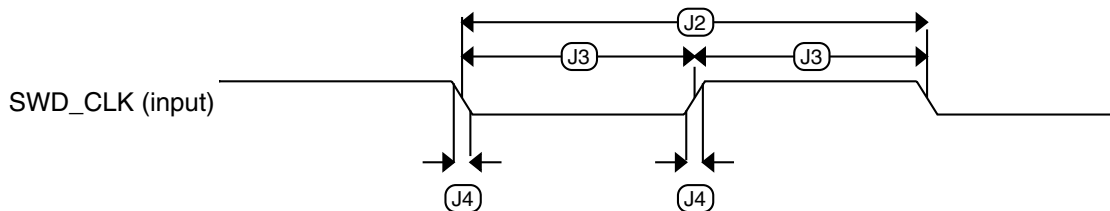

Figure 13. Serial wire clock input timing

Peripheral operating requirements and behaviors

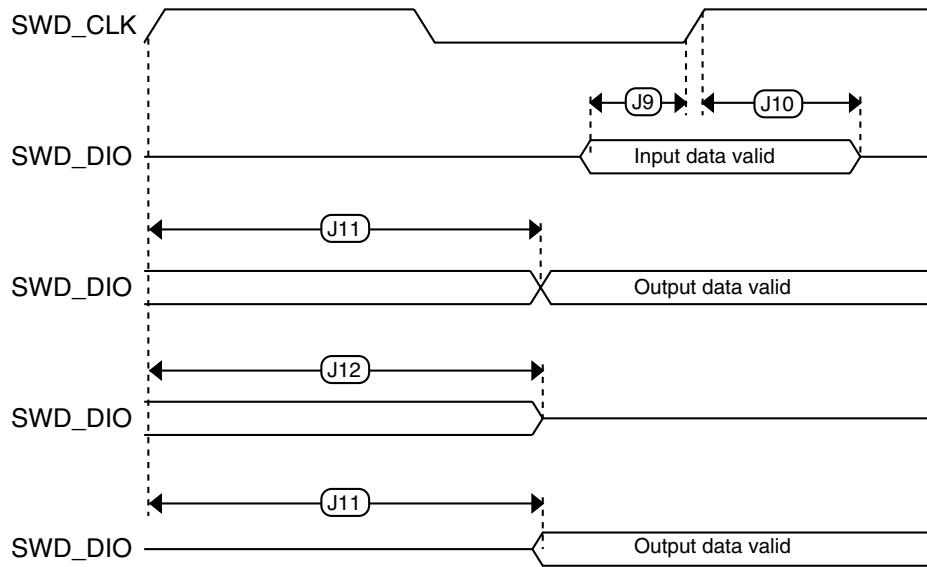

Figure 14. Serial wire data timing

6.2 External oscillator (OSC) and ICS characteristics

Table 11. OSC and ICS specifications (temperature range = -40 to 105 °C ambient)

Num	C	Characteristic		Symbol	Min	Typical ¹	Max	Unit
1	C	Crystal or resonator frequency	Low range (RANGE = 0)	f_{lo}	31.25	32.768	39.0625	kHz
	C		High range (RANGE = 1)	f_{hi}	4	—	24	MHz
2	D	Load capacitors		C1, C2	See Note ²			
3	D	Feedback resistor	Low Frequency, Low-Power Mode ³	R_F	—	—	—	MΩ
			Low Frequency, High-Gain Mode		—	10	—	MΩ
			High Frequency, Low-Power Mode		—	1	—	MΩ
			High Frequency, High-Gain Mode		—	1	—	MΩ
4	D	Series resistor - Low Frequency	Low-Power Mode ³	R_S	—	0	—	kΩ
			High-Gain Mode		—	200	—	kΩ
5	D	Series resistor - High Frequency	Low-Power Mode ³	R_S	—	0	—	kΩ

Table continues on the next page...

Peripheral operating requirements and behaviors

**Table 11. OSC and ICS specifications (temperature range = -40 to 105 °C ambient)
 (continued)**

Num	C	Characteristic	Symbol	Min	Typical ¹	Max	Unit	
	D	Series resistor - High Frequency, High-Gain Mode		4 MHz	—	0	—	kΩ
	D			8 MHz	—	0	—	kΩ
	D			16 MHz	—	0	—	kΩ
6	C	Crystal start-up time low range = 32.768 kHz crystal; High range = 20 MHz crystal ^{4,5}	t_{CSTL}	Low range, low power	—	1000	—	ms
	C			Low range, high gain	—	800	—	ms
	C		High range, low power	t_{CSTH}	—	3	—	ms
	C		High range, high gain	—	1.5	—	ms	
7	T	Internal reference start-up time	t_{IRST}	—	20	50	μs	
8	P	Internal reference clock (IRC) frequency trim range	f_{int_t}	31.25	—	39.0625	kHz	
9	P	Internal reference clock frequency, factory trimmed	f_{int_ft}	—	37.5	—	kHz	
10	P	DCO output frequency range	f_{dco}	40	—	50	MHz	
11	P	Factory trimmed internal oscillator accuracy	Δf_{int_ft}	-0.5	—	0.5	%	
12	C	Deviation of IRC over temperature when trimmed at T = 25 °C, V _{DD} = 5 V	Δf_{int_t}	Over temperature range from -40 °C to 105°C	-1	—	0.5	%
				Over temperature range from 0 °C to 105°C	-0.5	—	0.5	
13	C	Frequency accuracy of DCO output using factory trim value	Δf_{dco_ft}	Over temperature range from -40 °C to 105°C	-1.5	—	1	%
				Over temperature range from 0 °C to 105°C	-1	—	1	
14	C	FLL acquisition time ^{4,6}	$t_{Acquire}$	—	—	2	ms	
15	C	Long term jitter of DCO output clock (averaged over 2 ms interval) ⁷	C_{Jitter}	—	0.02	0.2	% f_{dco}	

1. Data in Typical column was characterized at 5.0 V, 25 °C or is typical recommended value.
2. See crystal or resonator manufacturer's recommendation.
3. Load capacitors (C₁, C₂), feedback resistor (R_F) and series resistor (R_S) are incorporated internally when RANGE = HGO = 0.
4. This parameter is characterized and not tested on each device.
5. Proper PC board layout procedures must be followed to achieve specifications.
6. This specification applies to any time the FLL reference source or reference divider is changed, trim value changed, or changing from FLL disabled (FBELP, FBILP) to FLL enabled (FEI, FEE, FBE, FBI). If a crystal/resonator is being used as the reference, this specification assumes it is already running.
7. Jitter is the average deviation from the programmed frequency measured over the specified interval at maximum f_{BUS} . Measurements are made with the device powered by filtered supplies and clocked by a stable external clock signal. Noise injected into the FLL circuitry via V_{DD} and V_{SS} and variation in crystal oscillator frequency increase the C_{Jitter} percentage for a given interval.

Peripheral operating requirements and behaviors

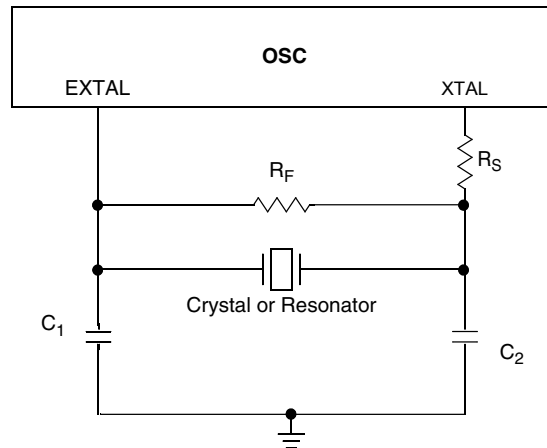

Figure 15. Typical crystal or resonator circuit

6.3 NVM specifications

This section provides details about program/erase times and program/erase endurance for the flash memories.

Table 12. Flash characteristics

C	Characteristic	Symbol	Min ¹	Typical ²	Max ³	Unit ⁴
D	Supply voltage for program/erase -40 °C to 105 °C	$V_{\text{prog/erase}}$	2.7	—	5.5	V
D	Supply voltage for read operation	V_{Read}	2.7	—	5.5	V
D	NVM Bus frequency	f_{NVMBUS}	1	—	24	MHz
D	NVM Operating frequency	f_{NVMOP}	0.8	1	1.05	MHz
D	Erase Verify All Blocks	t_{VFYALL}	—	—	2605	t_{cyc}
D	Erase Verify Flash Block	t_{RD1BLK}	—	—	2579	t_{cyc}
D	Erase Verify Flash Section	t_{RD1SEC}	—	—	485	t_{cyc}
D	Read Once	t_{RDONCE}	—	—	464	t_{cyc}
D	Program Flash (2 word)	t_{PGM2}	0.12	0.13	0.31	ms
D	Program Flash (4 word)	t_{PGM4}	0.21	0.21	0.49	ms
D	Program Once	t_{PGMONCE}	0.20	0.21	0.21	ms
D	Erase All Blocks	t_{ERSALL}	95.42	100.18	100.30	ms
D	Erase Flash Block	t_{ERSBLK}	95.42	100.18	100.30	ms
D	Erase Flash Sector	t_{ERSPG}	19.10	20.05	20.09	ms
D	Unsecure Flash	t_{UNSECU}	95.42	100.19	100.31	ms
D	Verify Backdoor Access Key	t_{VFYKEY}	—	—	482	t_{cyc}
D	Set User Margin Level	t_{MLOADU}	—	—	415	t_{cyc}
C	FLASH Program/erase endurance T_L to $T_H = -40$ °C to 105 °C	n_{FLPE}	10 k	100 k	—	Cycles

Table continues on the next page...

Peripheral operating requirements and behaviors

Table 12. Flash characteristics (continued)

C	Characteristic	Symbol	Min ¹	Typical ²	Max ³	Unit ⁴
C	Data retention at an average junction temperature of $T_{Javg} = 85^{\circ}C$ after up to 10,000 program/erase cycles	t_{D_ret}	15	100	—	years

1. Minimum times are based on maximum f_{NVMOP} and maximum f_{NVMBUS}
2. Typical times are based on typical f_{NVMOP} and maximum f_{NVMBUS}
3. Maximum times are based on typical f_{NVMOP} and typical f_{NVMBUS} plus aging
4. $t_{cyc} = 1 / f_{NVMBUS}$

Program and erase operations do not require any special power sources other than the normal V_{DD} supply. For more detailed information about program/erase operations, see the Flash Memory Module section in the reference manual.

6.4 Analog

6.4.1 ADC characteristics

Table 13. 5 V 12-bit ADC operating conditions

Characteristic	Conditions	Symbol	Min	Typ ¹	Max	Unit	Comment
Reference potential	• Low	V_{REFL}	V_{SSA}	—	$V_{DDA}/2$	V	—
	• High	V_{REFH}	$V_{DDA}/2$	—	V_{DDA}		
Supply voltage	Absolute	V_{DDA}	2.7	—	5.5	V	—
	Delta to V_{DD} ($V_{DD}-V_{DDA}$)	ΔV_{DDA}	-100	0	+100	mV	—
Input voltage		V_{ADIN}	V_{REFL}	—	V_{REFH}	V	—
Input capacitance		C_{ADIN}	—	4.5	5.5	pF	—
Input resistance		R_{ADIN}	—	3	5	k Ω	—
Analog source resistance	12-bit mode	R_{AS}	—	—	2	k Ω	External to MCU
	• $f_{ADCK} > 4$ MHz		—	—	5		
	• $f_{ADCK} < 4$ MHz		—	—	5		
10-bit mode	—	—	5	k Ω	External to MCU		
• $f_{ADCK} > 4$ MHz	—	—	10				
• $f_{ADCK} < 4$ MHz	—	—	10				
8-bit mode (all valid f_{ADCK})			—	—	10		
ADC conversion clock frequency	High speed (ADLPC=0)	f_{ADCK}	0.4	—	8.0	MHz	—
	Low power (ADLPC=1)		0.4	—	4.0		

Peripheral operating requirements and behaviors

1. Typical values assume $V_{DDA} = 5.0\text{ V}$, $\text{Temp} = 25^\circ\text{C}$, $f_{\text{ADCK}} = 1.0\text{ MHz}$ unless otherwise stated. Typical values are for reference only and are not tested in production.

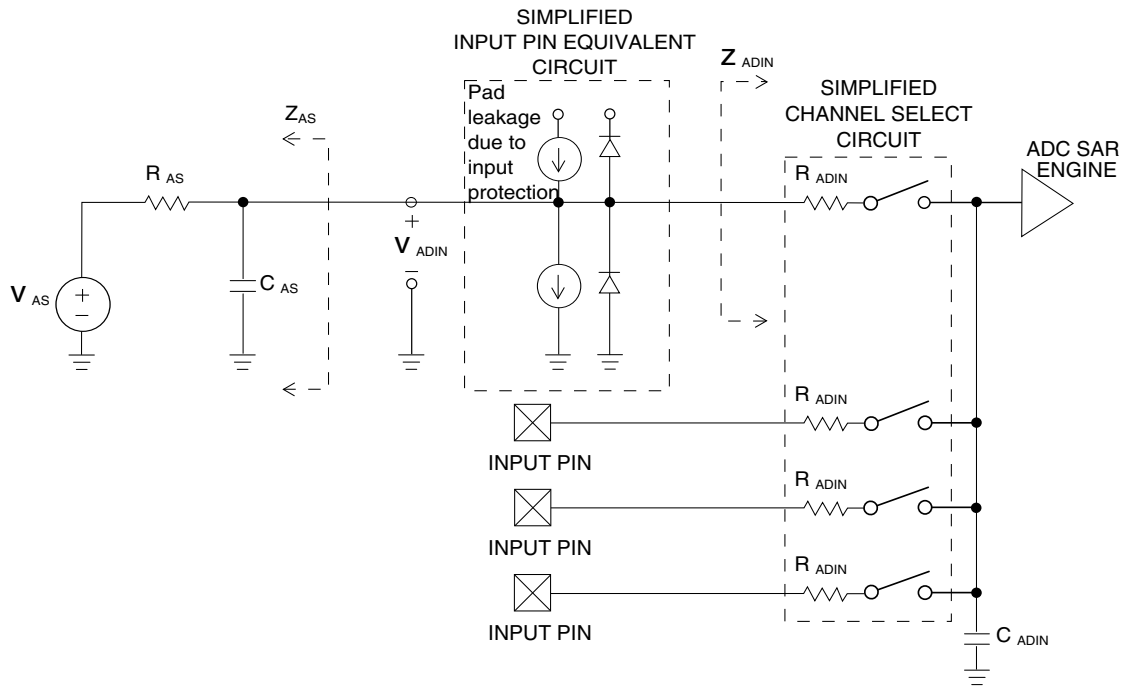

Figure 16. ADC input impedance equivalency diagram

Table 14. 12-bit ADC characteristics ($V_{\text{REFH}} = V_{\text{DDA}}$, $V_{\text{REFL}} = V_{\text{SSA}}$)

Characteristic	Conditions	C	Symbol	Min	Typ ¹	Max	Unit
Supply current		T	I_{DDA}	—	133	—	μA
ADLPC = 1							
ADLSMP = 1							
ADCO = 1							
Supply current		T	I_{DDA}	—	218	—	μA
ADLPC = 1							
ADLSMP = 0							
ADCO = 1							
Supply current		T	I_{DDA}	—	327	—	μA
ADLPC = 0							
ADLSMP = 1							
ADCO = 1							
Supply current		T	I_{DDA}	—	582	990	μA
ADLPC = 0							
ADLSMP = 0							
ADCO = 1							
Supply current	Stop, reset, module off	T	I_{DDA}	—	0.011	1	μA

Table continues on the next page...

Peripheral operating requirements and behaviors

Table 14. 12-bit ADC characteristics ($V_{REFH} = V_{DDA}$, $V_{REFL} = V_{SSA}$) (continued)

Characteristic	Conditions	C	Symbol	Min	Typ ¹	Max	Unit
ADC asynchronous clock source	High speed (ADLPC = 0)	P	f_{ADACK}	2	3.3	5	MHz
	Low power (ADLPC = 1)			1.25	2	3.3	
Conversion time (including sample time)	Short sample (ADLSMP = 0)	T	t_{ADC}	—	20	—	ADCK cycles
	Long sample (ADLSMP = 1)			—	40	—	
Sample time	Short sample (ADLSMP = 0)	T	t_{ADS}	—	3.5	—	ADCK cycles
	Long sample (ADLSMP = 1)			—	23.5	—	
Total unadjusted Error ²	12-bit mode	C	E_{TUE}	—	±5.0	—	LSB ³
	10-bit mode	C		—	±1.5	—	
	8-bit mode	C		—	±0.8	—	
Differential Non-Linearity	12-bit mode	C	DNL	—	±1.5	—	LSB ³
	10-bit mode	C		—	±0.4	—	
	8-bit mode	C		—	±0.15	—	
Integral Non-Linearity	12-bit mode	C	INL	—	±1.5	—	LSB ³
	10-bit mode	C		—	±0.4	—	
	8-bit mode	C		—	±0.15	—	
Zero-scale error ⁴	12-bit mode	C	E_{ZS}	—	±1.0	—	LSB ³
	10-bit mode	C		—	±0.2	—	
	8-bit mode	C		—	±0.35	—	
Full-scale error ⁵	12-bit mode	C	E_{FS}	—	±2.5	—	LSB ³
	10-bit mode	C		—	±0.3	—	
	8-bit mode	C		—	±0.25	—	
Quantization error	≤12 bit modes	D	E_Q	—	—	±0.5	LSB ³
Input leakage error ⁶	all modes	D	E_{IL}	$I_{In} * R_{AS}$			mV
Temp sensor slope	-40 °C–25 °C	D	m	—	3.266	—	mV/°C
	25 °C–125 °C			—	3.638	—	
Temp sensor voltage	25 °C	D	V_{TEMP25}	—	1.396	—	V

1. Typical values assume $V_{DDA} = 5.0$ V, Temp = 25 °C, $f_{ADCK} = 1.0$ MHz unless otherwise stated. Typical values are for reference only and are not tested in production.
2. Includes quantization
3. $1 \text{ LSB} = (V_{REFH} - V_{REFL})/2^N$
4. $V_{ADIN} = V_{SSA}$
5. $V_{ADIN} = V_{DDA}$
6. I_{In} = leakage current (refer to DC characteristics)

6.4.2 Analog comparator (ACMP) electricals

Table 15. Comparator electrical specifications

C	Characteristic	Symbol	Min	Typical	Max	Unit
D	Supply voltage	V_{DDA}	2.7	—	5.5	V
T	Supply current (Operation mode)	I_{DDA}	—	10	20	μ A
D	Analog input voltage	V_{AIN}	$V_{SS} - 0.3$	—	V_{DDA}	V
P	Analog input offset voltage	V_{AIO}	—	—	40	mV
C	Analog comparator hysteresis (HYST=0)	V_H	—	15	20	mV
C	Analog comparator hysteresis (HYST=1)	V_H	—	20	30	mV
T	Supply current (Off mode)	I_{DDAOFF}	—	60	—	nA
C	Propagation Delay	t_D	—	0.4	1	μ s

6.5 Communication interfaces

6.5.1 SPI switching specifications

The serial peripheral interface (SPI) provides a synchronous serial bus with master and slave operations. Many of the transfer attributes are programmable. The following tables provide timing characteristics for classic SPI timing modes. See the SPI chapter of the chip's reference manual for information about the modified transfer formats used for communicating with slower peripheral devices. All timing is shown with respect to 20% V_{DD} and 80% V_{DD} , unless noted, and 25 pF load on all SPI pins. All timing assumes slew rate control is disabled and high-drive strength is enabled for SPI output pins.

Table 16. SPI master mode timing

Nu m.	Symbol	Description	Min.	Max.	Unit	Comment
1	f_{op}	Frequency of operation	$f_{BUS}/2048$	$f_{BUS}/2$	Hz	f_{BUS} is the bus clock
2	t_{SPSCK}	SPSCK period	$2 \times t_{BUS}$	$2048 \times t_{BUS}$	ns	$t_{BUS} = 1/f_{BUS}$
3	t_{Lead}	Enable lead time	1/2	—	t_{SPSCK}	—
4	t_{Lag}	Enable lag time	1/2	—	t_{SPSCK}	—
5	t_{WSPSCK}	Clock (SPSCK) high or low time	$t_{BUS} - 30$	$1024 \times t_{BUS}$	ns	—
6	t_{SU}	Data setup time (inputs)	8	—	ns	—
7	t_{HI}	Data hold time (inputs)	8	—	ns	—
8	t_v	Data valid (after SPSCK edge)	—	25	ns	—
9	t_{HO}	Data hold time (outputs)	20	—	ns	—
10	t_{RI}	Rise time input	—	$t_{BUS} - 25$	ns	—

Table continues on the next page...

Peripheral operating requirements and behaviors

Table 16. SPI master mode timing (continued)

Nu m.	Symbol	Description	Min.	Max.	Unit	Comment
	t_{FI}	Fall time input				
11	t_{RO}	Rise time output	—	25	ns	—
	t_{FO}	Fall time output				

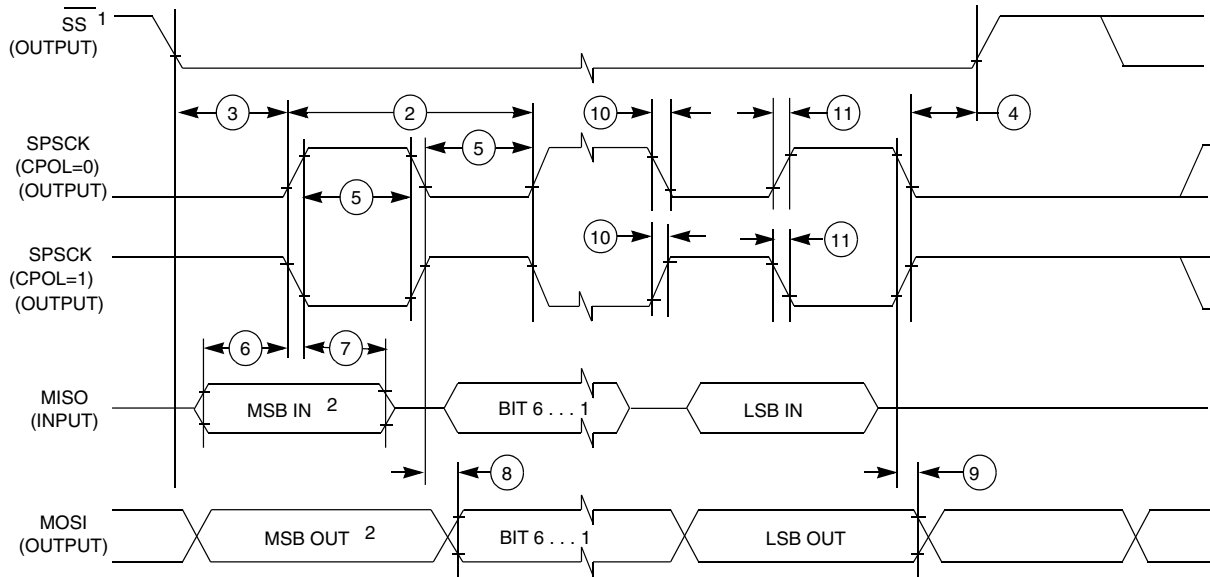

1. If configured as an output.
2. LSBF = 0. For LSBF = 1, bit order is LSB, bit 1, ..., bit 6, MSB.

Figure 17. SPI master mode timing (CPHA=0)

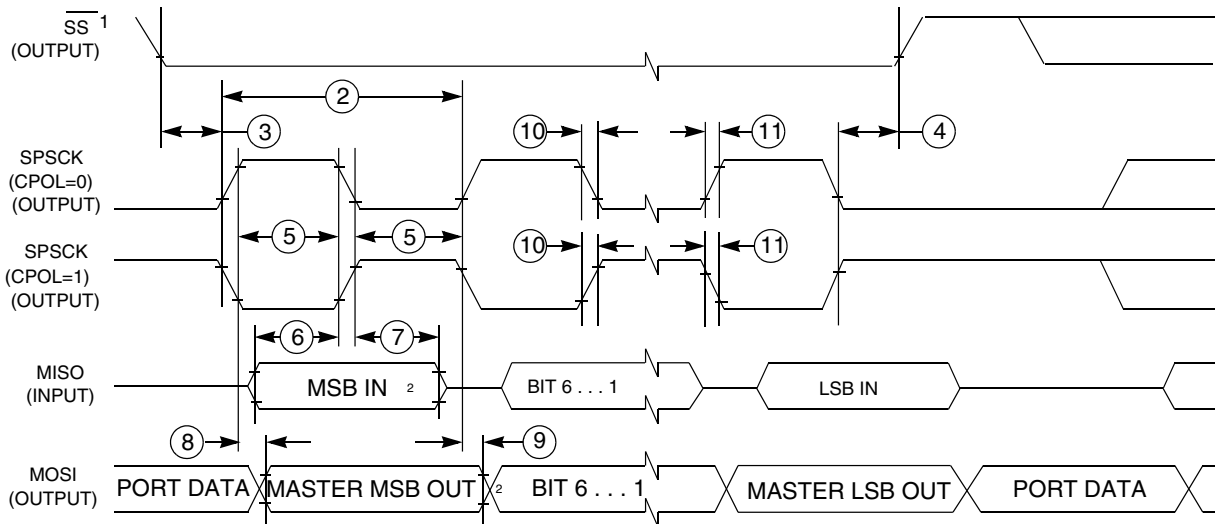

1. If configured as output
2. LSBF = 0. For LSBF = 1, bit order is LSB, bit 1, ..., bit 6, MSB.

Figure 18. SPI master mode timing (CPHA=1)

Peripheral operating requirements and behaviors

Table 17. SPI slave mode timing

Nu m.	Symbol	Description	Min.	Max.	Unit	Comment
1	f_{op}	Frequency of operation	0	$f_{Bus}/4$	Hz	f_{Bus} is the bus clock as defined in Control timing .
2	t_{SPSCK}	SPSCK period	$4 \times t_{Bus}$	—	ns	$t_{Bus} = 1/f_{Bus}$
3	t_{Lead}	Enable lead time	1	—	t_{Bus}	—
4	t_{Lag}	Enable lag time	1	—	t_{Bus}	—
5	t_{WSPSCK}	Clock (SPSCK) high or low time	$t_{Bus} - 30$	—	ns	—
6	t_{SU}	Data setup time (inputs)	15	—	ns	—
7	t_{HI}	Data hold time (inputs)	25	—	ns	—
8	t_a	Slave access time	—	t_{Bus}	ns	Time to data active from high-impedance state
9	t_{dis}	Slave MISO disable time	—	t_{Bus}	ns	Hold time to high-impedance state
10	t_v	Data valid (after SPSCK edge)	—	25	ns	—
11	t_{HO}	Data hold time (outputs)	0	—	ns	—
12	t_{RI}	Rise time input	—	$t_{Bus} - 25$	ns	—
	t_{FI}	Fall time input				
13	t_{RO}	Rise time output	—	25	ns	—
	t_{FO}	Fall time output				

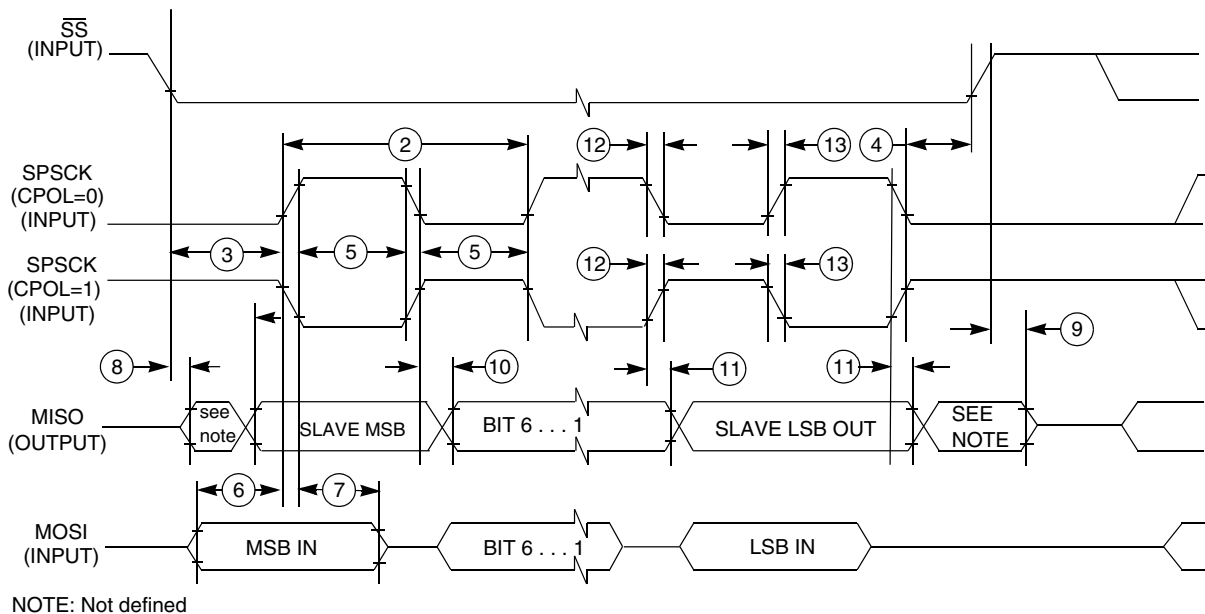
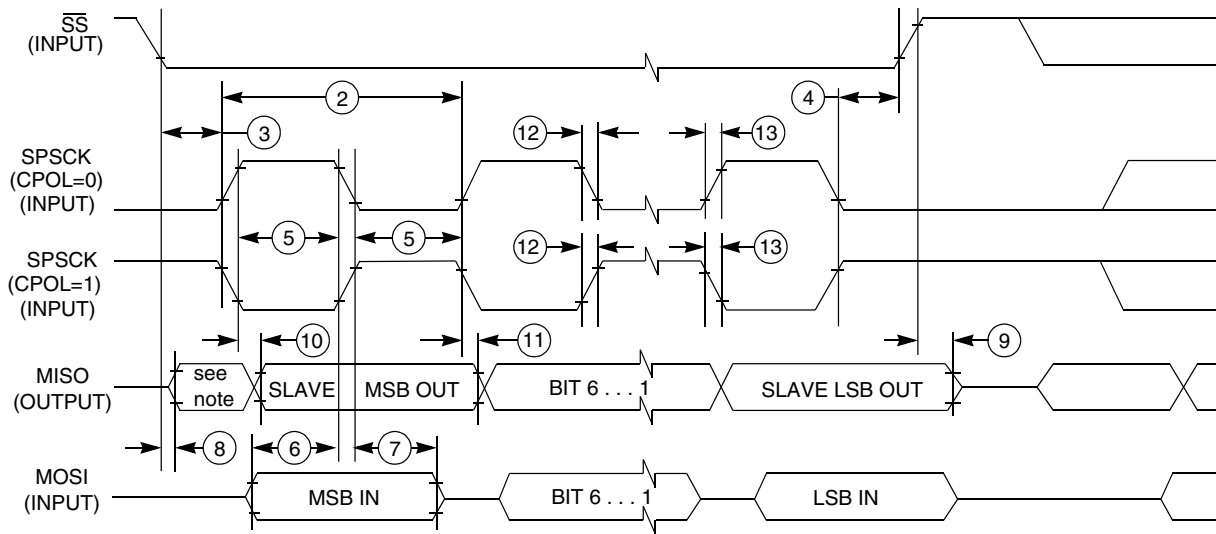

Figure 19. SPI slave mode timing (CPHA = 0)

Dimensions



NOTE: Not defined

Figure 20. SPI slave mode timing (CPHA=1)

6.5.2 MSCAN

Table 18. MSCAN wake-up pulse characteristics

Parameter	Symbol	Min	Typ	Max	Unit
MSCAN wakeup dominant pulse filtered	t_{WUP}	-	-	1.5	μs
MSCAN wakeup dominant pulse pass	t_{WUP}	5	-	-	μs

7 Dimensions

7.1 Obtaining package dimensions

Package dimensions are provided in package drawings.

To find a package drawing, go to freescale.com and perform a keyword search for the drawing's document number:

If you want the drawing for this package	Then use this document number
44-pin LQFP	98ASS23225W
64-pin QFP	98ASB42844B
64-pin LQFP	98ASS23234W
80-pin LQFP	98ASS23237W

8 Pinout

8.1 Signal multiplexing and pin assignments

The following table shows the signals available on each pin and the locations of these pins on the devices supported by this document. The Port Control Module is responsible for selecting which ALT functionality is available on each pin.

NOTE

VSS and VSSA are internally connected.

VREFH and VDDA are internally connected in 64-pin packages.

PTB4, PTB5, PTD0, PTD1, PTE0, PTE1, PTH0, and PTH1 are high-current drive pins when operated as output.

PTA2 and PTA3 are true open-drain pins when operated as output.

80 LQFP	64 LQFP /QFP	44 LQFP	Pin Name	Default	ALT0	ALT1	ALT2	ALT3	ALT4	ALT5	ALT6	ALT7
1	1	1	PTD1	DISABLED	PTD1	KB10_P25	FTM2_CH3	SPI1_MOSI				
2	2	2	PTD0	DISABLED	PTD0	KB10_P24	FTM2_CH2	SPI1_SCK				
3	3	—	PTH7	DISABLED	PTH7	KB11_P31	PWT_IN1					
4	4	—	PTH6	DISABLED	PTH6	KB11_P30						
5	—	—	PTH5	DISABLED	PTH5	KB11_P29						
6	5	3	PTE7	DISABLED	PTE7	KB11_P7	TCLK2		FTM1_CH1	CAN0_TX		
7	6	4	PTH2	DISABLED	PTH2	KB11_P26	BUSOUT		FTM1_CH0	CAN0_RX		
8	7	5	VDD	VDD							VDD	
9	8	6	VDDA	VDDA						VREFH	VDDA	
10	—	—	VREFH	VREFH							VREFH	
11	9	7	VREFL	VREFL							VREFL	
12	10	8	VSS/ VSSA	VSS/ VSSA						VSSA	VSS	
13	11	9	PTB7	EXTAL	PTB7	KB10_P15	I2C0_SCL				EXTAL	
14	12	10	PTB6	XTAL	PTB6	KB10_P14	I2C0_SDA				XTAL	
15	13	11	PTI4	DISABLED	PTI4		IRQ					
16	—	—	PTI1	DISABLED	PTI1		IRQ	UART2_TX				
17	—	—	PTI0	DISABLED	PTI0		IRQ	UART2_RX				
18	14	—	PTH1	DISABLED	PTH1	KB11_P25	FTM2_CH1					

Pinout

80 LQFP	64 LQFP /QFP	44 LQFP	Pin Name	Default	ALT0	ALT1	ALT2	ALT3	ALT4	ALT5	ALT6	ALT7
19	15	—	PTH0	DISABLED	PTH0	KB11_P24	FTM2_CH0					
20	16	—	PTE6	DISABLED	PTE6	KB11_P6						
21	17	—	PTE5	DISABLED	PTE5	KB11_P5						
22	18	12	PTB5	DISABLED	PTB5	KB10_P13	FTM2_CH5	SPI0_PCS	ACMP1_OUT			
23	19	13	PTB4	NMI_b	PTB4	KB10_P12	FTM2_CH4	SPI0_MISO	ACMP1_IN2	NMI_b		
24	20	14	PTC3	ADC0_SE11	PTC3	KB10_P19	FTM2_CH3		ADC0_SE11			
25	21	15	PTC2	ADC0_SE10	PTC2	KB10_P18	FTM2_CH2		ADC0_SE10			
26	22	16	PTD7	DISABLED	PTD7	KB10_P31	UART2_TX					
27	23	17	PTD6	DISABLED	PTD6	KB10_P30	UART2_RX					
28	24	18	PTD5	DISABLED	PTD5	KB10_P29	PWT_IN0					
29	—	—	PTI6	DISABLED	PTI6	IRQ						
30	—	—	PTI5	DISABLED	PTI5	IRQ						
31	25	19	PTC1	ADC0_SE9	PTC1	KB10_P17	FTM2_CH1		ADC0_SE9			
32	26	20	PTC0	ADC0_SE8	PTC0	KB10_P16	FTM2_CH0		ADC0_SE8			
33	—	—	PTH4	DISABLED	PTH4	KB11_P28	I2C1_SCL					
34	—	—	PTH3	DISABLED	PTH3	KB11_P27	I2C1_SDA					
35	27	—	PTF7	ADC0_SE15	PTF7	KB11_P15			ADC0_SE15			
36	28	—	PTF6	ADC0_SE14	PTF6	KB11_P14			ADC0_SE14			
37	29	—	PTF5	ADC0_SE13	PTF5	KB11_P13			ADC0_SE13			
38	30	—	PTF4	ADC0_SE12	PTF4	KB11_P12			ADC0_SE12			
39	31	21	PTB3	ADC0_SE7	PTB3	KB10_P11	SPI0_MOSI	FTM0_CH1	ADC0_SE7			
40	32	22	PTB2	ADC0_SE6	PTB2	KB10_P10	SPI0_SCK	FTM0_CH0	ADC0_SE6			
41	33	23	PTB1	ADC0_SE5	PTB1	KB10_P9	UART0_TX		ADC0_SE5			
42	34	24	PTB0	ADC0_SE4	PTB0	KB10_P8	UART0_RX	PWT_IN1	ADC0_SE4			
43	35	—	PTF3	DISABLED	PTF3	KB11_P11	UART1_TX					
44	36	—	PTF2	DISABLED	PTF2	KB11_P10	UART1_RX					
45	37	25	PTA7	ADC0_SE3	PTA7	KB10_P7	FTM2_FLT2	ACMP1_IN1	ADC0_SE3			
46	38	26	PTA6	ADC0_SE2	PTA6	KB10_P6	FTM2_FLT1	ACMP1_IN0	ADC0_SE2			
47	39	—	PTE4	DISABLED	PTE4	KB11_P4						
48	40	27	VSS	VSS							VSS	
49	41	28	VDD	VDD							VDD	
50	—	—	PTG7	DISABLED	PTG7	KB11_P23	FTM2_CH5	SPI1_PCS				
51	—	—	PTG6	DISABLED	PTG6	KB11_P22	FTM2_CH4	SPI1_MISO				
52	—	—	PTG5	DISABLED	PTG5	KB11_P21	FTM2_CH3	SPI1_MOSI				
53	—	—	PTG4	DISABLED	PTG4	KB11_P20	FTM2_CH2	SPI1_SCK				
54	42	—	PTF1	DISABLED	PTF1	KB11_P9	FTM2_CH1					
55	43	—	PTF0	DISABLED	PTF0	KB11_P8	FTM2_CH0					
56	44	29	PTD4	DISABLED	PTD4	KB10_P28						
57	45	30	PTD3	DISABLED	PTD3	KB10_P27	SPI1_PCS					
58	46	31	PTD2	DISABLED	PTD2	KB10_P26	SPI1_MISO					

Pinout

80 LQFP	64 LQFP /QFP	44 LQFP	Pin Name	Default	ALT0	ALT1	ALT2	ALT3	ALT4	ALT5	ALT6	ALT7
59	47	32	PTA3	DISABLED	PTA3	KBIO_P3	UART0_TX	I2C0_SCL				
60	48	33	PTA2	DISABLED	PTA2	KBIO_P2	UART0_RX	I2C0_SDA				
61	49	34	PTA1	ADC0_SE1	PTA1	KBIO_P1	FTM0_CH1	I2C0_4WSDAOUT	ACMP0_IN1	ADC0_SE1		
62	50	35	PTA0	ADC0_SE0	PTA0	KBIO_P0	FTM0_CH0	I2C0_4WSCLOUT	ACMP0_IN0	ADC0_SE0		
63	51	36	PTC7	DISABLED	PTC7	KBIO_P23	UART1_TX			CAN0_TX		
64	52	37	PTC6	DISABLED	PTC6	KBIO_P22	UART1_RX			CAN0_RX		
65	—	—	PTI3	DISABLED	PTI3	IRQ						
66	—	—	PTI2	DISABLED	PTI2	IRQ						
67	53	—	PTE3	DISABLED	PTE3	KBI1_P3	SPI0_PCS					
68	54	38	PTE2	DISABLED	PTE2	KBI1_P2	SPI0_MISO	PWT_IN0				
69	—	—	VSS	VSS							VSS	
70	—	—	VDD	VDD							VDD	
71	55	—	PTG3	DISABLED	PTG3	KBI1_P19						
72	56	—	PTG2	DISABLED	PTG2	KBI1_P18						
73	57	—	PTG1	DISABLED	PTG1	KBI1_P17						
74	58	—	PTG0	DISABLED	PTG0	KBI1_P16						
75	59	39	PTE1	DISABLED	PTE1	KBI1_P1	SPI0_MOSI		I2C1_SCL			
76	60	40	PTE0	DISABLED	PTE0	KBI1_P0	SPI0_SCK	TCLK1	I2C1_SDA			
77	61	41	PTC5	DISABLED	PTC5	KBIO_P21		FTM1_CH1		RTC_CLKOUT		
78	62	42	PTC4	SWD_CLK	PTC4	KBIO_P20	RTC_CLKOUT	FTM1_CH0	ACMP0_IN2	SWD_CLK		
79	63	43	PTA5	RESET_b	PTA5	KBIO_P5	IRQ	TCLK0	RESET_b			
80	64	44	PTA4	SWD_DIO	PTA4	KBIO_P4		ACMP0_OUT	SWD_DIO			

8.2 Device pin assignment

Pinout

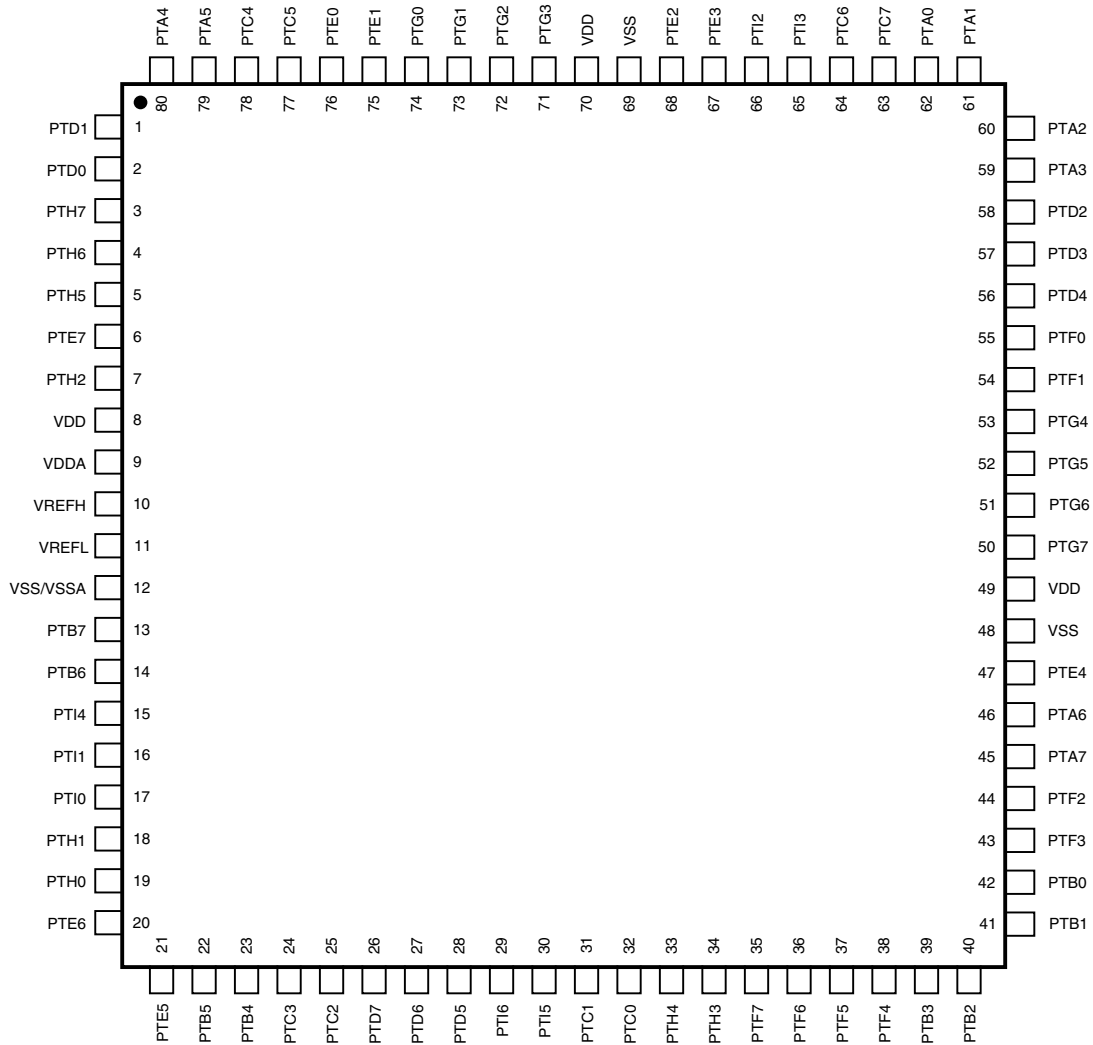

Figure 21. 80-pin LQFP package

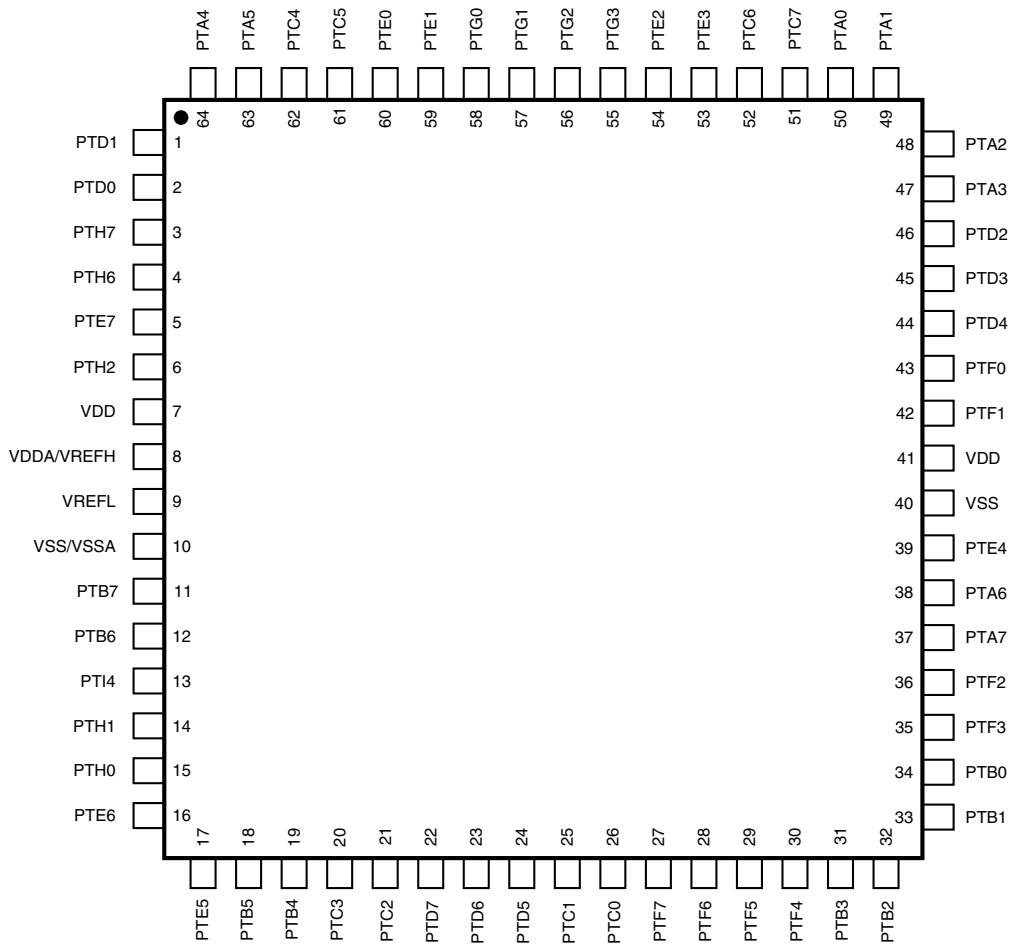

Figure 22. 64-pin QFP/LQFP packages

revision history

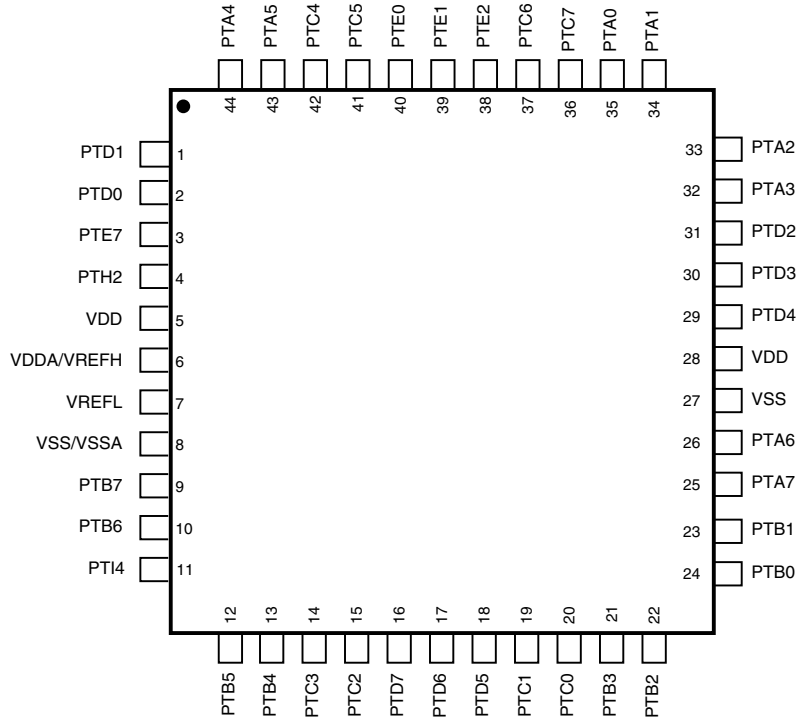

Figure 23. 44-pin LQFP package

9 Revision history

The following table provides a revision history for this document.

Table 19. Revision history

Rev. No.	Date	Substantial Changes
2	3/2014	Initial public release.

Table continues on the next page...

Table 19. Revision history (continued)

Rev. No.	Date	Substantial Changes
3	5/2014	<ul style="list-style-type: none"> • Updated the Max. of S_{IDD}. • Updated footnote to the V_{OH}. • Corrected Unit in the FTM input timing table.

How to Reach Us:**Home Page:**freescale.com**Web Support:**freescale.com/support

Information in this document is provided solely to enable system and software implementers to use Freescale products. There are no express or implied copyright licenses granted hereunder to design or fabricate any integrated circuits based on the information in this document. Freescale reserves the right to make changes without further notice to any products herein.

Freescale makes no warranty, representation, or guarantee regarding the suitability of its products for any particular purpose, nor does Freescale assume any liability arising out of the application or use of any product or circuit, and specifically disclaims any and all liability, including without limitation consequential or incidental damages.

“Typical” parameters that may be provided in Freescale data sheets and/or specifications can and do vary in different applications, and actual performance may vary over time. All operating parameters, including “typicals,” must be validated for each customer application by customer’s technical experts. Freescale does not convey any license under its patent rights nor the rights of others. Freescale sells products pursuant to standard terms and conditions of sale, which can be found at the following address: freescale.com/SalesTermsandConditions.

Freescale, the Freescale logo, and Kinetis are trademarks of Freescale Semiconductor, Inc., Reg. U.S. Pat. & Tm. Off. All other product or service names are the property of their respective owners. ARM and Cortex-M0+ are the registered trademarks of ARM Limited.

©2013-2014 Freescale Semiconductor, Inc.