

Excellent Integrated System Limited

Stocking Distributor

Click to view price, real time Inventory, Delivery & Lifecycle Information:

[STMicroelectronics](#)

[STH140N8F7-2](#)

For any questions, you can email us directly:

sales@integrated-circuit.com



STH140N8F7-2

N-channel 80 V, 3.3 mΩ typ., 90 A STripFET™ F7 Power MOSFET in a H2PAK-2 package

Datasheet - production data

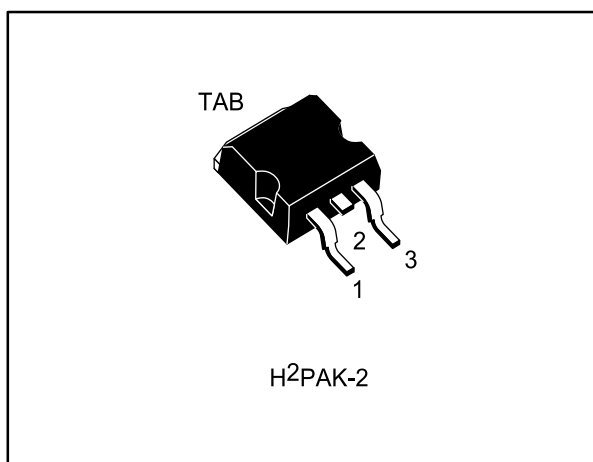
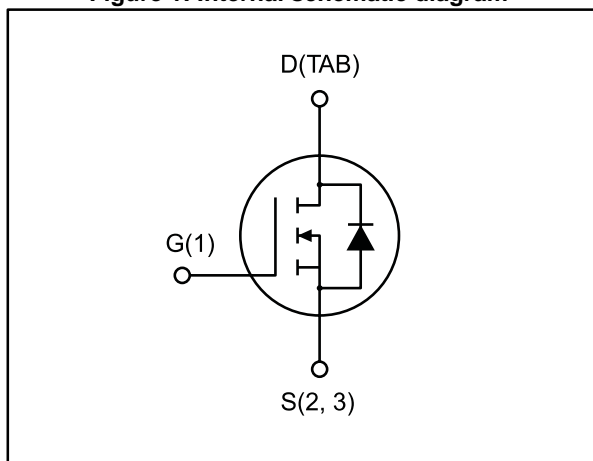

Figure 1: Internal schematic diagram



Features

Order code	V _{DS}	R _{DS(on)} max.	I _D	P _{TOT}
STH140N8F7-2	80 V	4 mΩ	90 A	200 W

- Among the lowest R_{DS(on)} on the market
- Excellent figure of merit (FoM)
- Low C_{rss}/C_{iss} ratio for EMI immunity
- High avalanche ruggedness

Applications

- Switching applications

Description

This N-channel Power MOSFET utilizes STripFET™ F7 technology with an enhanced trench gate structure that results in very low on-state resistance, while also reducing internal capacitance and gate charge for faster and more efficient switching.

Table 1: Device summary

Order code	Marking	Package	Packaging
STH140N8F7-2	140N8F7	H2PAK-2	Tape and reel

Contents

1	Electrical ratings	3
2	Electrical characteristics	4
	2.1 Electrical characteristics (curves).....	5
3	Test circuit	7
4	Package mechanical data	8
	4.1 H2PAK-2 mechanical data	9
5	Packaging mechanical data.....	12
6	Revision history	14

1 Electrical ratings

Table 2: Absolute maximum ratings

Symbol	Parameter	Value	Unit
V _{DS}	Drain-source voltage	80	V
V _{GS}	Gate-source voltage	± 20	V
I _D	Drain current (continuous) at T _C = 25 ° C	90 ⁽¹⁾	A
I _D	Drain current (continuous) at T _C = 100 ° C	90	A
I _{DM} ⁽²⁾	Drain current (pulsed)	360	A
P _{TOT}	Total dissipation at T _C = 25 ° C	200	W
E _{AS} ⁽³⁾	Single pulse avalanche energy	515	mJ
T _j	Operating junction temperature	- 55 to 175	° C
T _{stg}	Storage temperature		

Notes:

- (1)Limited by package
- (2)Pulse width is limited by safe operating area
- (3)Starting T_j =25 ° C, I_d = 18.5 A, V_{dd} = 50 V

Table 3: Thermal data

Symbol	Parameter	Value	Unit
R _{thj-pcb} ⁽¹⁾	Thermal resistance junction-pcb	35	° C/W
R _{thj-case}	Thermal resistance junction-case	0.75	° C/W

Notes:

- (1)When mounted on FR-4 board of 1inch² , 2oz Cu

Electrical characteristics

STH140N8F7-2

2 Electrical characteristics

(T_{CASE} = 25 ° C unless otherwise specified)

Table 4: On/off states

Symbol	Parameter	Test conditions	Min.	Typ.	Max.	Unit
V _{(BR)DSS}	Drain-source breakdown voltage	V _{GS} = 0, I _D = 250 μA	80			V
I _{DSS}	Zero gate voltage Drain current	V _{GS} = 0, V _{DS} = 80 V			1	μA
		V _{GS} = 0, V _{DS} = 80 V, T _J = 125 ° C			10	μA
I _{GSS}	Gate-source leakage current	V _{DS} = 0, V _{GS} = ± 20 V			± 100	nA
V _{GS(th)}	Gate threshold voltage	V _{DS} = V _{GS} , I _D = 250 μA	2.5		4.5	V
R _{DS(on)}	Static drain-source on-resistance	V _{GS} = 10 V, I _D = 45 A		3.3	4	mΩ

Table 5: Dynamic

Symbol	Parameter	Test conditions	Min.	Typ.	Max.	Unit
C _{iss}	Input capacitance	V _{GS} = 0, V _{DS} = 40 V, f = 1 MHz	-	6340	-	pF
C _{oss}	Output capacitance		-	1195	-	pF
C _{rss}	Reverse transfer capacitance		-	105	-	pF
Q _g	Total gate charge	V _{DD} = 40 V, I _D = 64 A, V _{GS} = 10 V	-	96	-	nC
Q _{gs}	Gate-source charge		-	30	-	nC
Q _{gd}	Gate-drain charge		-	26	-	nC

Table 6: Switching times

Symbol	Parameter	Test conditions	Min.	Typ.	Max.	Unit
t _{d(on)}	Turn-on delay time	V _{DD} = 40 V, I _D = 45 A R _G = 4.7 Ω, V _{GS} = 10 V	-	26	-	ns
t _r	Rise time		-	51	-	ns
t _{d(off)}	Turn-off-delay time		-	82	-	ns
t _f	Fall time		-	44	-	ns

Table 7: Source drain diode

Symbol	Parameter	Test conditions	Min.	Typ.	Max.	Unit
I _{SD}	Source-drain current		-		90	A
I _{SDM} ⁽¹⁾	Source-drain current (pulsed)		-		360	A
V _{SD} ⁽²⁾	Forward on voltage	V _{GS} = 0, I _{SD} = 90 A	-		1.2	V
t _{rr}	Reverse recovery time	I _{SD} = 64 A, di/dt = 100 A/μs, V _{DD} = 60 V, T _J = 150 ° C	-	58		ns
Q _{rr}	Reverse recovery charge		-	92		nC
I _{RRM}	Reverse recovery current		-	3.2		A

Notes:

(1)Pulse width is limited by safe operating area

(2)Pulse test: pulse duration = 300 μ s, duty cycle 1.5%

STH140N8F7-2

Electrical characteristics

2.1 Electrical characteristics (curves)

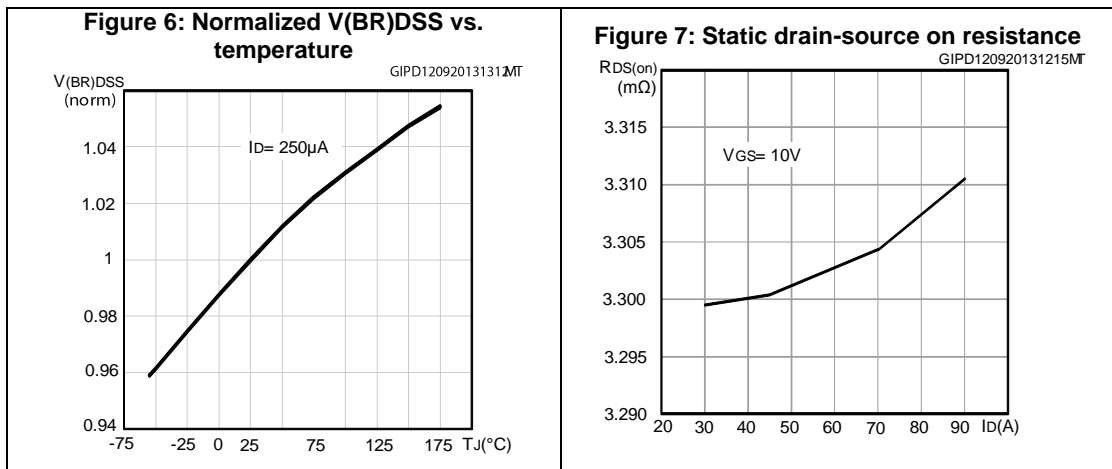
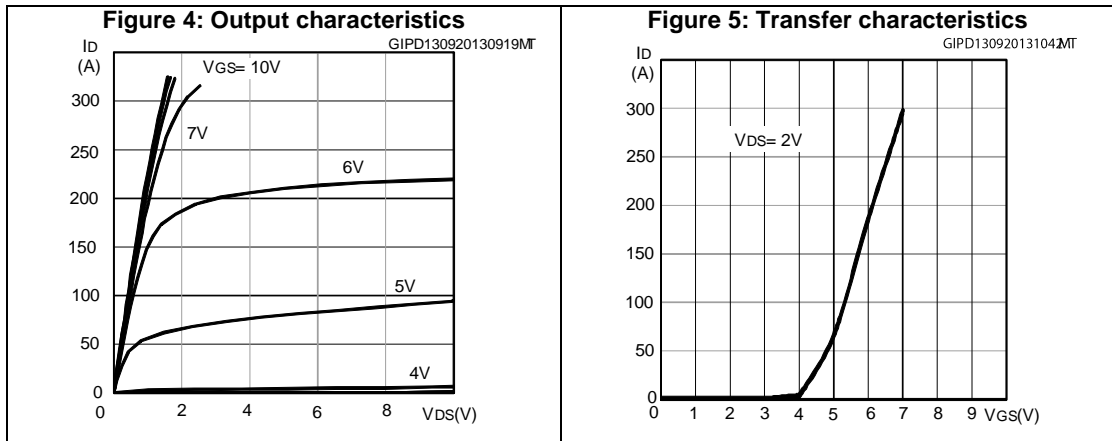
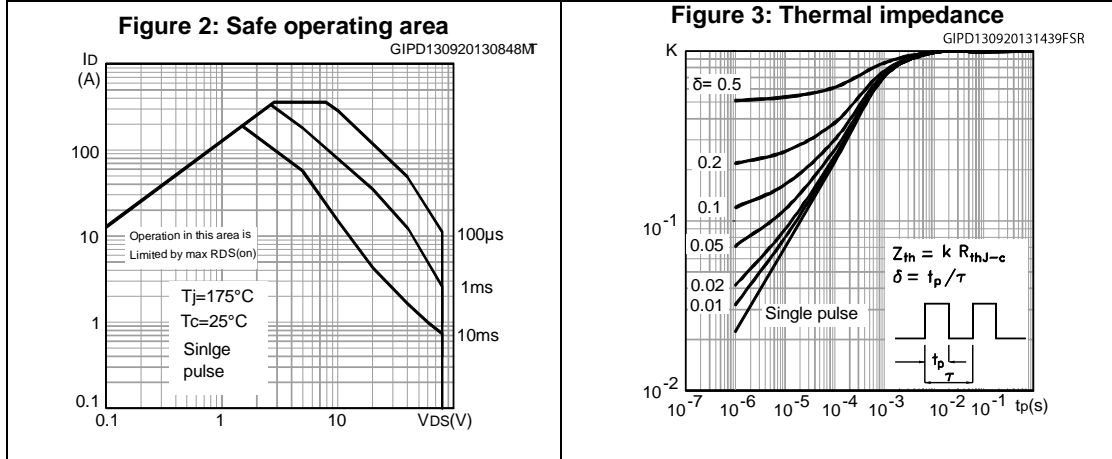

Electrical characteristics

STH140N8F7-2

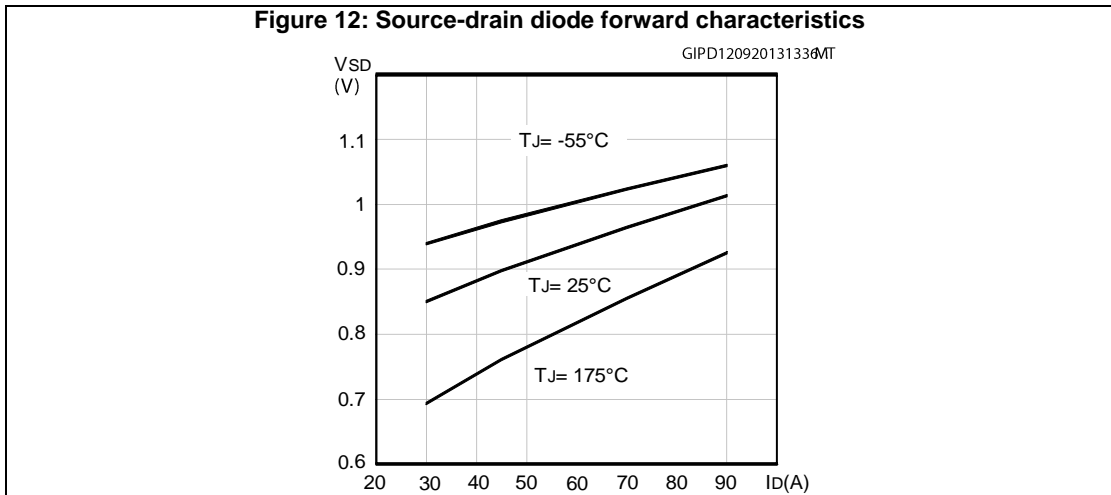
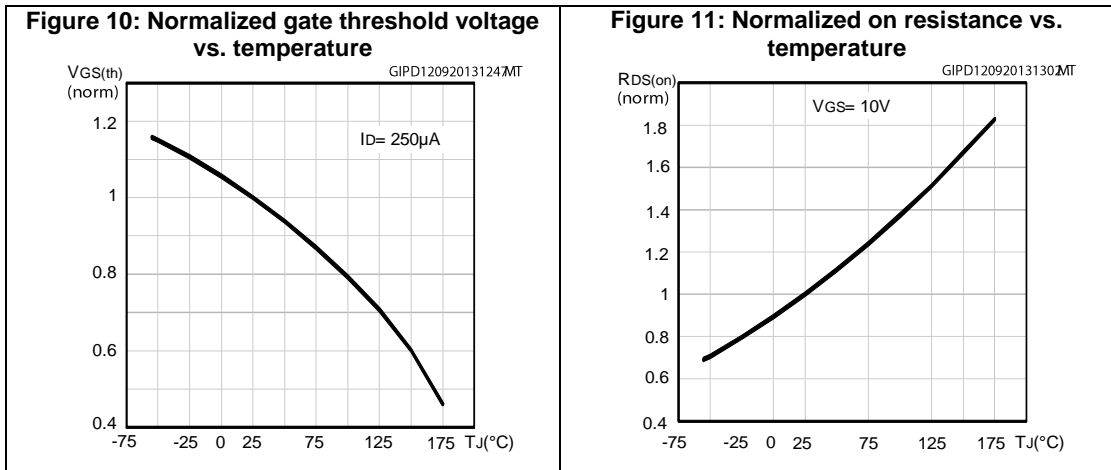
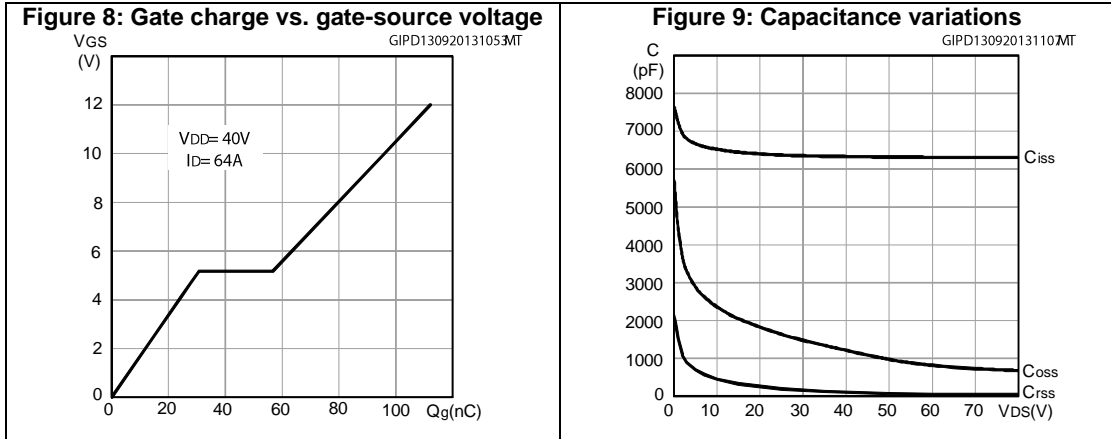

STH140N8F7-2

Test circuit

3 Test circuit

Figure 13: Switching times test circuit for resistive load

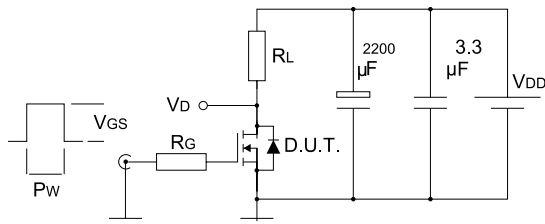

AM01468v1

Figure 14: Gate charge test circuit

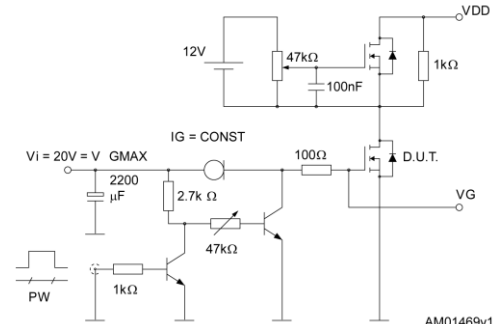

AM01469v1

Figure 15: Test circuit for inductive load switching and diode recovery times

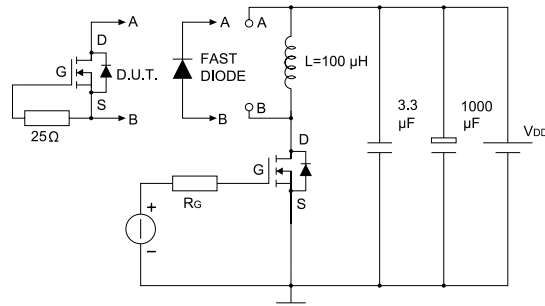

AM01470v1

Figure 16: Unclamped inductive load test circuit

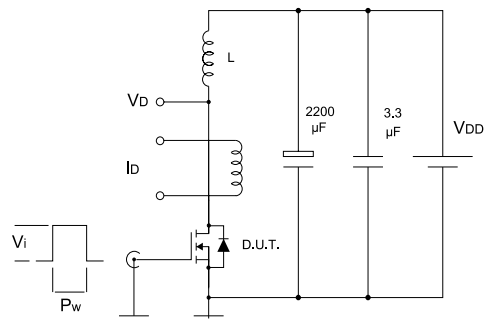

AM01471v1

Figure 17: Unclamped inductive waveform

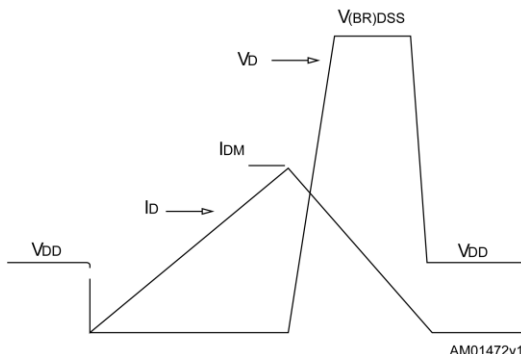

AM01472v1

Figure 18: Switching time waveform

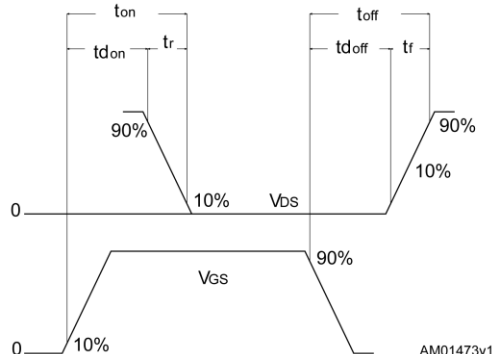

AM01473v1

4 Package mechanical data

In order to meet environmental requirements, ST offers these devices in different grades of ECOPACK® packages, depending on their level of environmental compliance. ECOPACK® specifications, grade definitions and product status are available at: www.st.com. ECOPACK® is an ST trademark.

STH140N8F7-2

Package mechanical data

4.1 H2PAK-2 mechanical data

Figure 19: H²PAK-2 leads drawing

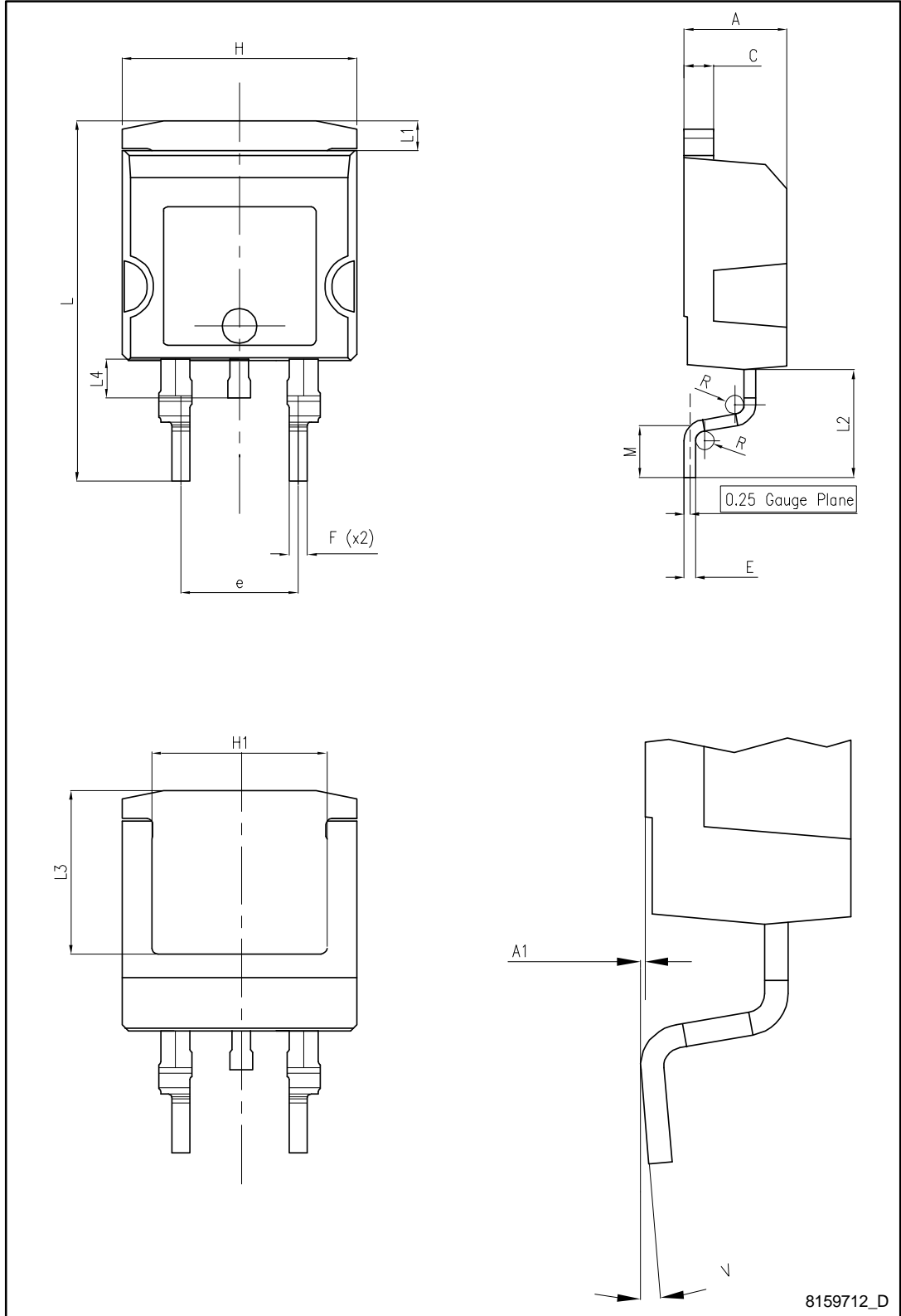

8159712_D

Package mechanical data

STH140N8F7-2

Table 8: H²PAK-2 leads mechanical data

Dim.	mm		
	Min.	Typ.	Max.
A	4.30		4.80
A1	0.03		0.20
C	1.17		1.37
e	4.98		5.18
E	0.50		0.90
F	0.78		0.85
H	10.00		10.40
H1	7.40		7.80
L	15.30		15.80
L1	1.27		1.40
L2	4.93		5.23
L3	6.85		7.25
L4	1.5		1.7
M	2.6		2.9
R	0.20		0.60
V	0°		8°

STH140N8F7-2

Package mechanical data

Figure 20: H²PAK-2 recommended footprint

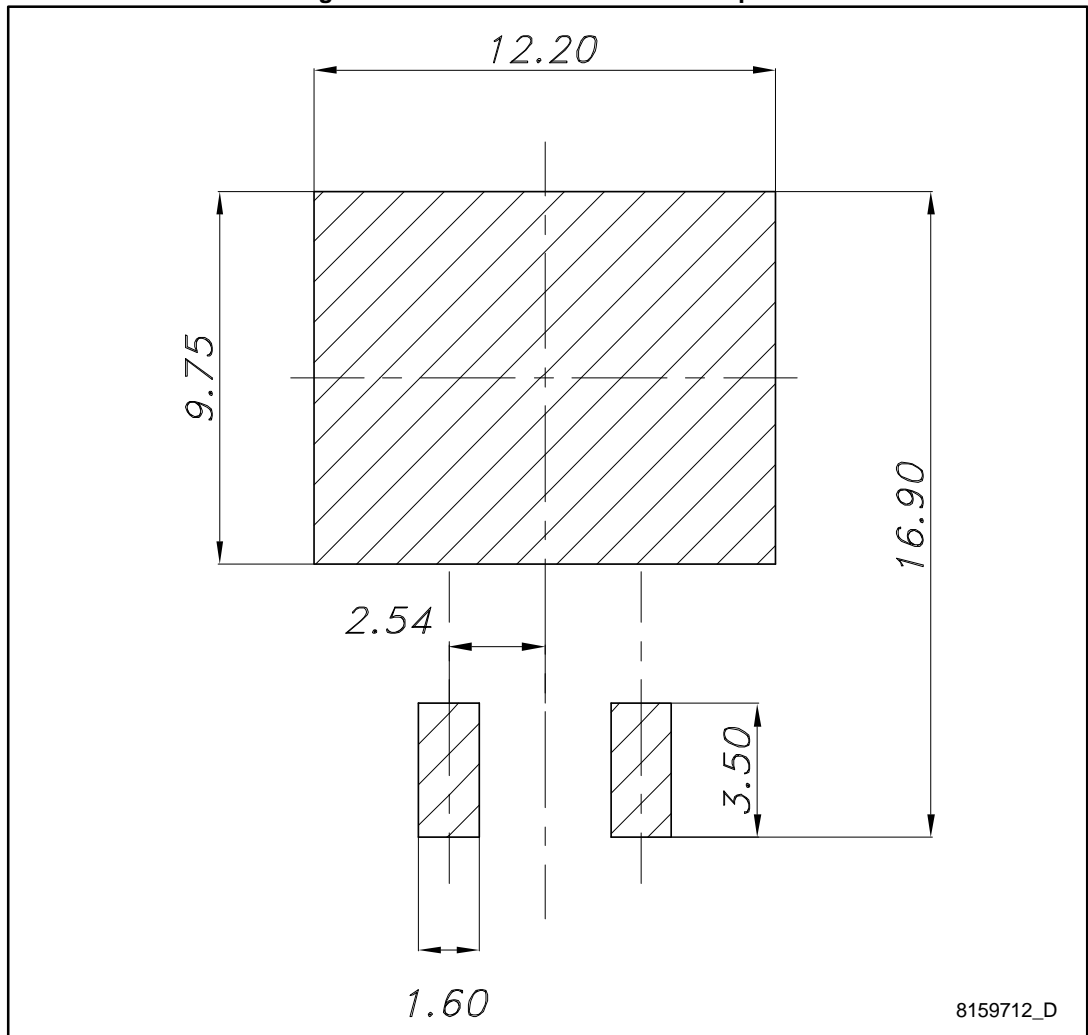

8159712_D

5 Packaging mechanical data

Figure 21: Tape

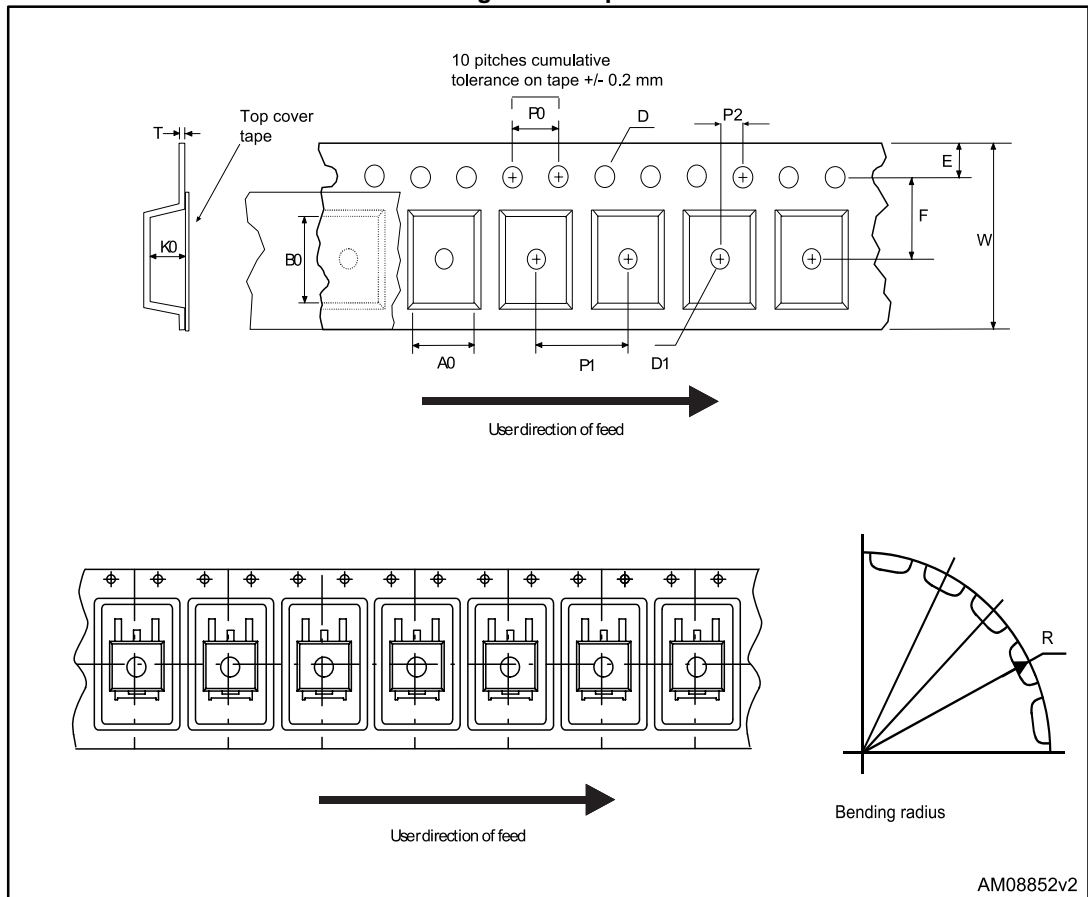

STH140N8F7-2

Packaging mechanical data

Figure 22: Reel

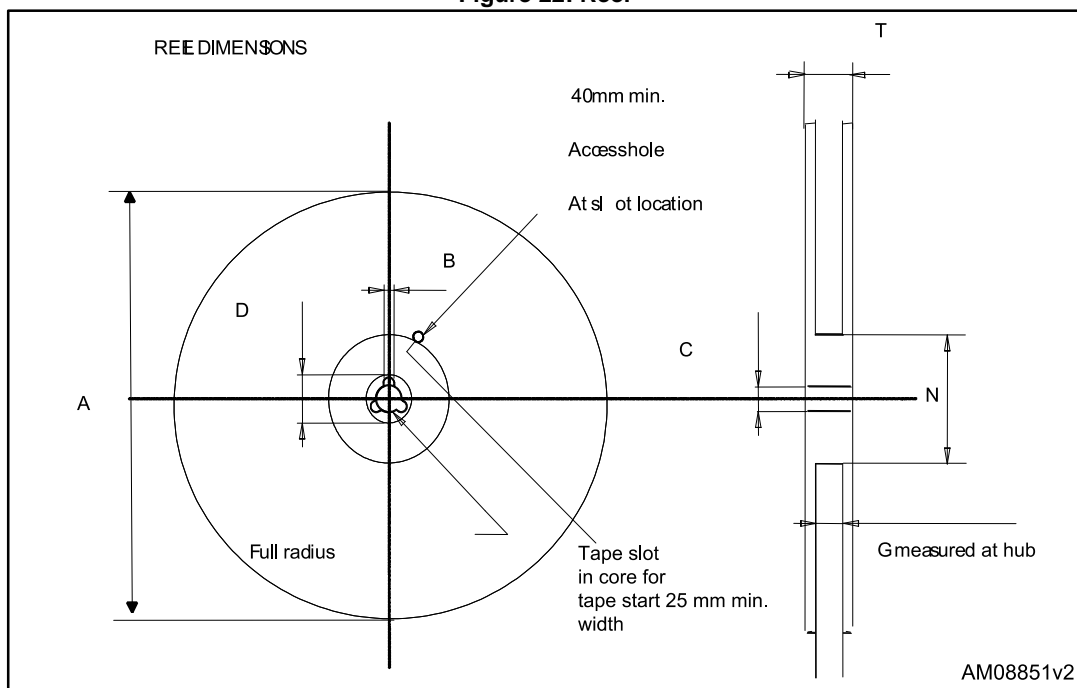

Table 9: Tape and reel mechanical data

Tape			Reel		
Dim.	mm		Dim.	mm	
	Min.	Max.		Min.	Max.
A0	10.5	10.7	A		330
B0	15.7	15.9	B	1.5	
D	1.5	1.6	C	12.8	13.2
D1	1.59	1.61	D	20.2	
E	1.65	1.85	G	24.4	26.4
F	11.4	11.6	N	100	
K0	4.8	5.0	T		30.4
P0	3.9	4.1			
P1	11.9	12.1	Base qty		1000
P2	1.9	2.1	Bulk qty		1000
R	50				
T	0.25	0.35			
W	23.7	24.3			

6 Revision history

Table 10: Document revision history

Date	Revision	Changes
25-Aug-2014	1	First release. Part numbers STF140N8F7 and STP140N8F7 previously included in the datasheet DocID023888.
10-Oct-2014	2	Updated <i>Figure 3: "Thermal impedance"</i>

STH140N8F7-2

IMPORTANT NOTICE – PLEASE READ CAREFULLY

STMicroelectronics NV and its subsidiaries (“ST”) reserve the right to make changes, corrections, enhancements, modifications, and improvements to ST products and/or to this document at any time without notice. Purchasers should obtain the latest relevant information on ST products before placing orders. ST products are sold pursuant to ST’s terms and conditions of sale in place at the time of order acknowledgement.

Purchasers are solely responsible for the choice, selection, and use of ST products and ST assumes no liability for application assistance or the design of Purchasers’ products.

No license, express or implied, to any intellectual property right is granted by ST herein.

Resale of ST products with provisions different from the information set forth herein shall void any warranty granted by ST for such product.

ST and the ST logo are trademarks of ST. All other product or service names are the property of their respective owners.

Information in this document supersedes and replaces information previously supplied in any prior versions of this document.

© 2014 STMicroelectronics – All rights reserved