

## **Excellent Integrated System Limited**

Stocking Distributor

Click to view price, real time Inventory, Delivery & Lifecycle Information:

[Amphenol Pcd](#)  
[SJT502101](#)

For any questions, you can email us directly:

[sales@integrated-circuit.com](mailto:sales@integrated-circuit.com)

PCD PART NO.	AIR FORCE PART NO. *	QUANTITY OF MODULES PER RAIL (SIZES 16, 20 & 22)	DIMENSIONS	
			A ±.015	B ±.015
SJT50210X	8027520-1-02	2	1.036	.518
SJT50310X	8027520-1-03	3	1.554	1.036
SJT50410X	8027520-1-04	4	2.072	1.554
SJT50510X	8027520-1-05	5	2.590	2.072
SJT50610X	8027520-1-06	6	3.108	2.590
SJT50710X	8027520-1-07	7	3.626	3.108
SJT50810X	8027520-1-08	8	4.144	3.626
SJT50910X	8027520-1-09	9	4.662	4.144
SJT51010X	8027520-1-10	10	5.180	4.662
SJT51110X	8027520-1-11	11	5.698	5.180
SJT51210X	8027520-1-12	12	6.216	5.698
SJT51310X	8027520-1-13	13	6.734	6.216
SJT51410X	8027520-1-14	14	7.252	6.734
SJT51510X	8027520-1-15	15	7.770	7.252
SJT51610X	8027520-1-16	16	8.288	7.770
SJT51710X	8027520-1-17	17	8.806	8.288
SJT51810X	8027520-1-18	18	9.324	8.806
SJT51910X	8027520-1-19	19	9.842	9.324
SJT52010X	8027520-1-20	20	10.360	9.842
SJT52110X	8027520-1-21	21	10.875	10.360

\* - REQUIRES NICKEL FINISH  
 TABLE 1

PCD P/N LAST DIGIT	EXTRUSION FINISH	MARKING COLOR
1	NICKEL PLATE	BLUE
2	CLEAR CADMIUM	BLUE
3	OLIVE DRAB CADMIUM	BLACK
4	BLACK ANODIZE	WHITE

TABLE 2

- NOTES:
- PART SHALL MEET ALL REQUIREMENTS OF U.S. AIR FORCE DRAWING NO. 8027520-1 UNLESS OTHERWISE SPECIFIED.
  - MATERIALS:
    - EXTRUSION - ALUMINUM ALLOY, FINISH PER TABLE 2.
    - CLIP - STAINLESS STEEL.
    - RIVET - STAINLESS STEEL.
  - MARKINGS ARE FLUSH WITH SURFACES; COLOR PER TABLE 2.
  - RAILS ACCEPT MODULES PER AFLC 8027520; PCD SJ SERIES.
  - QUANTITY OF SIZE 12 MODULES PER RAIL IS HALF THE QUANTITY OF SIZE 16, 20 & 22 MODULES (SEE TABLE 1).
  - MODULE REMOVAL TOOLS (REQUIRED TO REMOVE MODULES FROM RAIL - SUPPLIED SEPARATELY).
    - SIZES 16, 20 & 22 - AIR FORCE P/N 8027520-24-1; PCD P/N CNA051300.
    - SIZE 12 - AIR FORCE P/N 8027520-24-2; PCD P/N CNA052300.

AW-1001

REVISIONS				
REV	ECN	DESCRIPTION	DATE	APP
A	1357	REDRAWN		

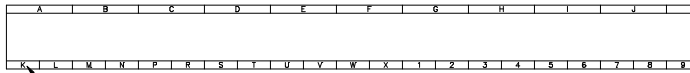

TOP MARKING  
 SCALE - 1:1

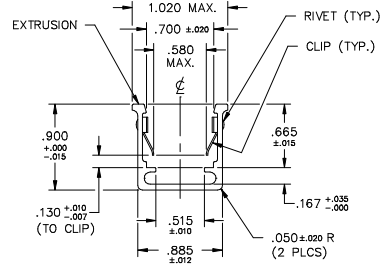
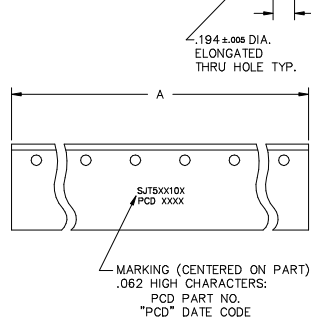
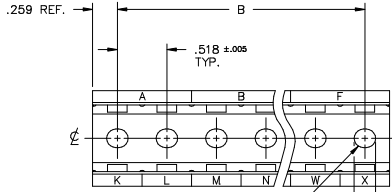

APPLIES TO ALL PCD P/N SJT5XX10X

DIMENSIONS=INCHES TOLERANCES .XX± .XXX± ANGLES±	THIRD ANGLE PROJECTION 	SPECIFICATION AFLC 8027520-1	PRECISION CONNECTOR DESIGNS, INC. PEABODY, MA 01960		
		DRAWN M. CALLA 8/18/88 CHECKED	SOCKET JUNCTION TRACK (RAIL) -ALPHA MARKING STYLE-		
THIS DOCUMENT CONTAINS PROPRIETARY INFORMATION WHICH IS THE CONFIDENTIAL PROPERTY OF PRECISION CONNECTOR DESIGNS, INC.		ENG.	SIZE C	CODE IDENT 58982	DRAWING NO. SJT502101
		BY DIR.	SCALE 1.5 : 1		SHEET 1 OF 1