

## Excellent Integrated System Limited

Stocking Distributor

Click to view price, real time Inventory, Delivery & Lifecycle Information:

[Soberton, Inc.](#)  
[WST-1612S](#)

For any questions, you can email us directly:

[sales@integrated-circuit.com](mailto:sales@integrated-circuit.com)

**Product Data Sheet**  
**Part No. WST-1612S Washable Type**

*(self drive circuit)*

**DIMENSIONS**

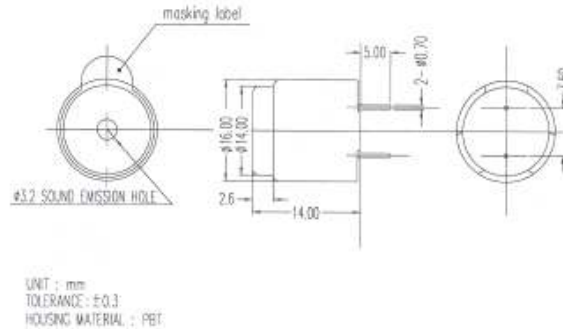

Type	Unit	
Color		Black
Rated Voltage	(V)	12
Operating Voltage	(V)	8-15
Current Consumption	(mA)	MAX.30
Sound Output (Min)	(dB)	85
Resonance Frequency	(Hz)	2300±300
Operating Temp	(C)	-20~+60
Storage Temp	(C)	-30~+70
Weight	(g)	7
Terminal		PIN TYPE
Dimension	mm	16 x H14
*applied voltage: rated voltage (DC)		
*distance for measurement 10cm		

**CHARACTERISTICS**

