

## Excellent Integrated System Limited

Stocking Distributor

Click to view price, real time Inventory, Delivery & Lifecycle Information:

[Advanced Photonix, Inc.](#)  
[PDB-C120-L](#)

For any questions, you can email us directly:

[sales@integrated-circuit.com](mailto:sales@integrated-circuit.com)

# PHOTONIC DETECTORS INC.

## Silicon Photodiode, Blue Enhanced Photoconductive Type PDB-C120L

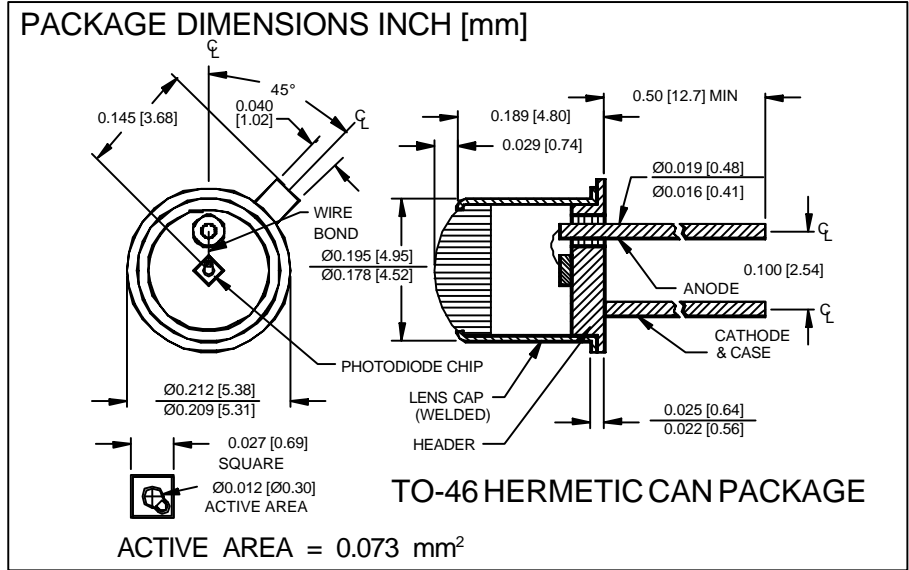

### FEATURES

- High speed
- Low capacitance
- Blue enhanced
- Low dark current

### DESCRIPTION

The **PDB-C120L** is a silicon, PIN planar diffused, blue enhanced photodiode. Ideal for high speed photoconductive applications. Packaged in a hermetic TO-46 metal can with a glass lens cap.

### APPLICATIONS

- Fiber optic
- Laser detection
- Light demodulation
- Matched to I.R. LEDs

### ABSOLUTE MAXIMUM RATING (TA=25°C unless otherwise noted)

SYMBOL	PARAMETER	MIN	MAX	UNITS
V <sub>BR</sub>	Reverse Voltage		200	V
T <sub>STG</sub>	Storage Temperature	-65	+150	°C
T <sub>O</sub>	Operating Temperature Range	-55	+125	°C
T <sub>S</sub>	Soldering Temperature*		+240	°C
I <sub>L</sub>	Light Current		500	mA

\*1/16 inch from case for 3 secs max

### SPECTRAL RESPONSE

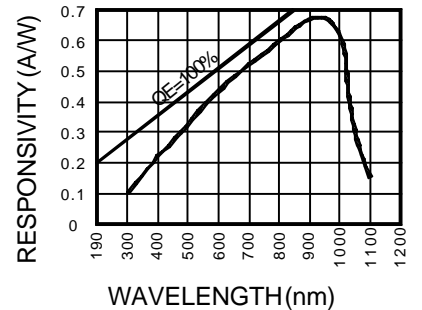

### ELECTRO-OPTICAL CHARACTERISTICS (TA=25°C unless otherwise noted)

SYMBOL	CHARACTERISTIC	TEST CONDITIONS	MIN	TYP	MAX	UNITS
I <sub>SC</sub>	Short Circuit Current	H = 100 fc, 2850 K	1.2	1.5		μA
I <sub>D</sub>	Dark Current	H = 0, V <sub>R</sub> = 10 V		0.5	2.0	nA
R <sub>SH</sub>	Shunt Resistance	H = 0, V <sub>R</sub> = 10 mV	400	500		MΩ
TCR <sub>SH</sub>	RSH Temp. Coefficient	H = 0, V <sub>R</sub> = 10 mV		-8		% / °C
C <sub>J</sub>	Junction Capacitance	H = 0, V <sub>R</sub> = 10 V**		1		pF
λ <sub>range</sub>	Spectral Application Range	Spot Scan	350		1100	nm
λ <sub>p</sub>	Spectral Response - Peak	Spot Scan		950		nm
V <sub>BR</sub>	Breakdown Voltage	I = 10 μA	100	150		V
NEP	Noise Equivalent Power	V <sub>R</sub> = 10 V @ Peak		9.0x10 <sup>-15</sup>		W/√Hz
tr	Response Time	RL = 1 KΩ V <sub>R</sub> = 50 V		1.0		nS

Information in this technical data sheet is believed to be correct and reliable. However, no responsibility is assumed for possible inaccuracies or omission. Specifications are subject to change without notice. \*\*f = 1 MHz