

## **Excellent Integrated System Limited**

Stocking Distributor

Click to view price, real time Inventory, Delivery & Lifecycle Information:

[Advanced Photonix, Inc.](#)  
[PDU-V402B](#)

For any questions, you can email us directly:  
[sales@integrated-circuit.com](mailto:sales@integrated-circuit.com)

# PHOTONIC DETECTORS INC.

## Silicon Photodiode, U.V. Enhanced Photovoltaic (center wavelength 320 nm) Type PDU-V402B

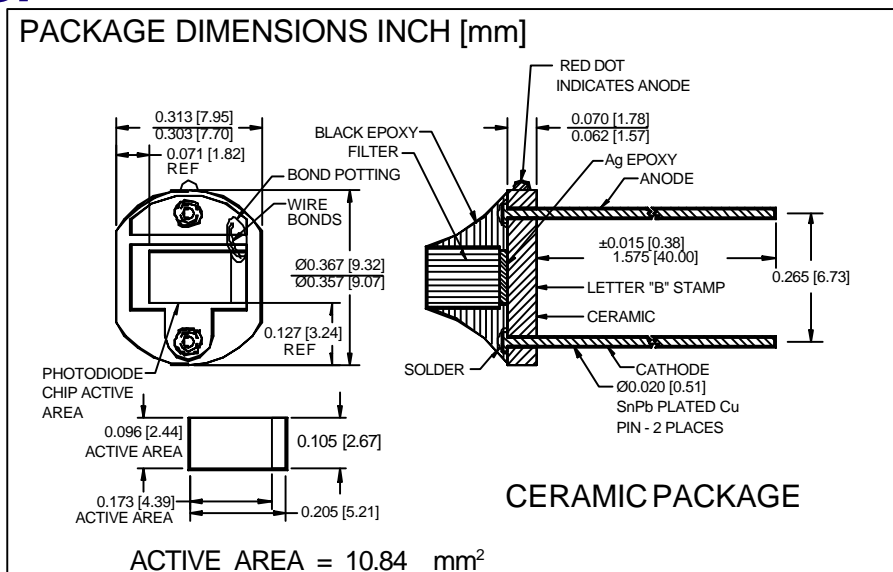

### FEATURES

- Built in filter
- U.V. enhanced
- I.R. blocking

### DESCRIPTION

The **PDU-V402B** is a silicon, PIN planar diffused, U.V. enhanced photodiode. Ideal for low noise photovoltaic applications. The filter is a U.V. type B with a center wavelength of 320 nm, with 10<sup>-3</sup> I.R. blocking. Packaged in a two lead ceramic base.

### APPLICATIONS

- U.V. detection
- U.V. A sensor
- U.V. radiometer

### ABSOLUTE MAXIMUM RATING (TA=25°C unless otherwise noted)

SYMBOL	PARAMETER	MIN	MAX	UNITS
V <sub>BR</sub>	Reverse Voltage		15	V
T <sub>STG</sub>	Storage Temperature	-55	+100	°C
T <sub>O</sub>	Operating Temperature Range	-40	+85	°C
T <sub>S</sub>	Soldering Temperature*		+260	°C
I <sub>L</sub>	Light Current		0.5	mA

\*1/16 inch from case for 3 secs max

### SPECTRAL RESPONSE

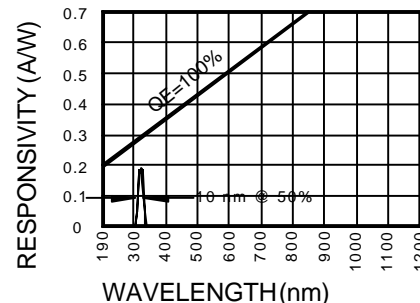

### ELECTRO-OPTICAL CHARACTERISTICS (TA=25°C unless otherwise noted)

SYMBOL	CHARACTERISTIC	TEST CONDITIONS	MIN	TYP	MAX	UNITS
I <sub>SC</sub>	Short Circuit Current	H = 100 fc, 2850 K	20	30		μA
I <sub>D</sub>	Dark Current	H = 0, V <sub>R</sub> = 10 mV		5	10	nA
R <sub>SH</sub>	Shunt Resistance	H = 0, V <sub>R</sub> = 10 mV	100	200		MΩ
TC R <sub>SH</sub>	RSH Temp. Coefficient	H = 0, V <sub>R</sub> = 10 mV		-8		% / °C
C <sub>J</sub>	Junction Capacitance	H = 0, V <sub>R</sub> = 0 V**		1250		pF
λ <sub>range</sub>	Spectral Application Range	Spot Scan	300	320	340	nm
R	Responsivity	V <sub>R</sub> = 0 V, λ = 320 nm		.08		A/W
V <sub>BR</sub>	Breakdown Voltage	I = 10 μA	15	30		V
NEP	Noise Equivalent Power	V <sub>R</sub> = 2 V @ Peak		1x10 <sup>-14</sup>		W / √Hz
tr	Response Time	RL = 1 KΩ V <sub>R</sub> = 0 V		1000		nS

Information in this technical data sheet is believed to be correct and reliable. However, no responsibility is assumed for possible inaccuracies or omission. Specifications are subject to change without notice. \*\*f = 1 MHz

[FORM NO. 100-PDU-V402B REV B]