

## Excellent Integrated System Limited

Stocking Distributor

Click to view price, real time Inventory, Delivery & Lifecycle Information:

[Molex Connector Corporation](#)  
[0621009780](#)

For any questions, you can email us directly:

[sales@integrated-circuit.com](mailto:sales@integrated-circuit.com)

Impel Daughtercard Removal Tool

<b>IMPEL™ Daughtercard Module Removal Tool</b>	<b>Application Tooling Specification Sheet</b>	<b>Order No. 62100-9780</b>
--	--	-----------------------------

**FEATURES**

- This tool is designed for the removal of an IMPEL™ Daughtercard module
- Removes Module without damage to the PCB
- Use tool 62201-8964 for inserting 4 pair by 16 column Daughtercard assemblies

**SCOPE**

Products: IMPEL™ Daughtercard signal module, 4 Pair by 16 columns (1.9mm pitch). See Product List below for order numbers.

**Product List**

The following is a partial list of the product order numbers and their specifications this tool is designed to run. Updates to this list are available on [www.molex.com](http://www.molex.com).

Series No.	Column	Guide Style	Daughtercard Module Order No.					
171320	16	Unguided	171320-1026					
		Left	171320-3026	171320-3126	171320-3226	171320-3326	171320-3426	171320-3526
			171320-3626	171320-3726	171320-3826			
		Right	171320-5026	171320-5126	171320-5226	171320-5326	171320-5426	171320-5526
			171320-5626	171320-5726	171320-5826			

**DESCRIPTION**

Figure 1 illustrates the principal parts of the removal tool.

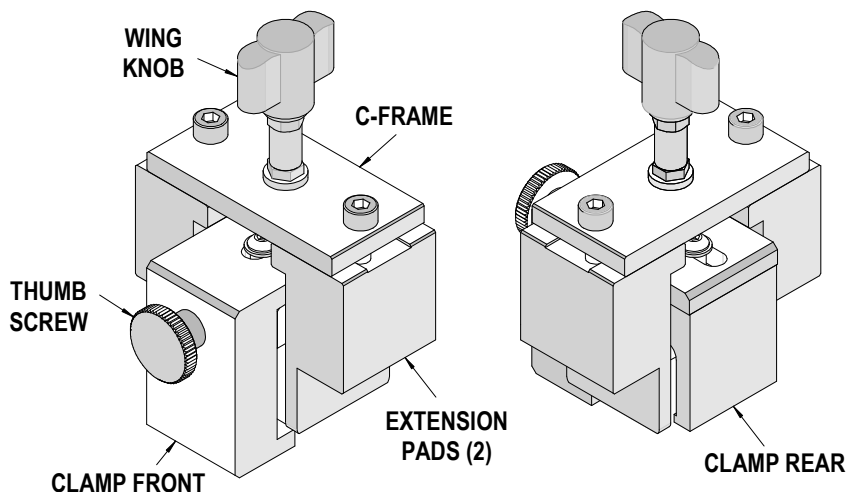

Figure 1

Impel Daughtercard Removal Tool

**Tool Restrictions**

These tools require a "Keep Out Zone" around the Module free of components. The rear of the Module should be 5.00mm (.197"). The right and left sides should be 5.00mm (.197"). See Figure 2. This is a general requirement, regardless of the module being removed.

**Note:** Be sure that all parts of the removal tool will clear any components on the printed circuit board during use. Tape may also be placed over circuit traces or on the bottom of the PCB Support for added protection of the printed circuit board.

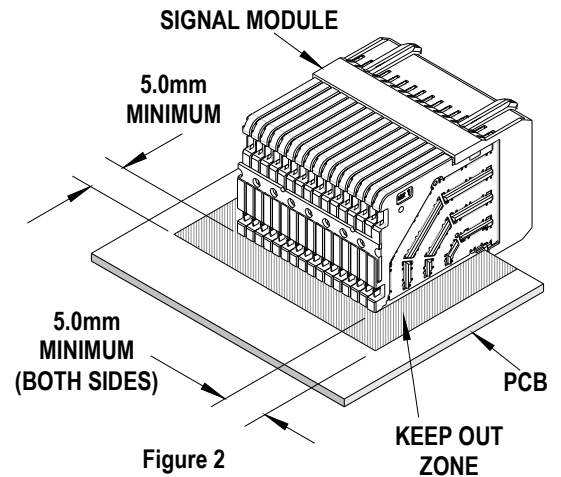

**Tool Operation**

1. Turn the wing knob counter clockwise so the clamp rear and clamp front are approximately 4mm below the bottom edge of the extension pads. See Figure 3.

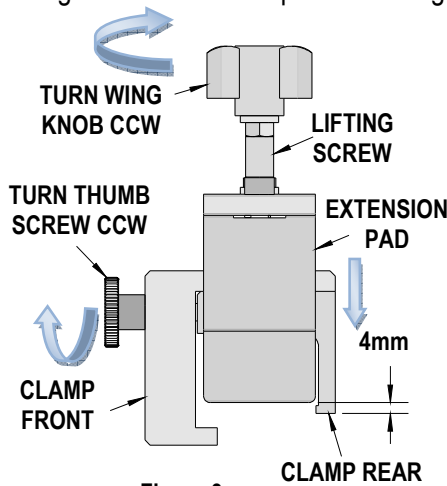

Figure 3

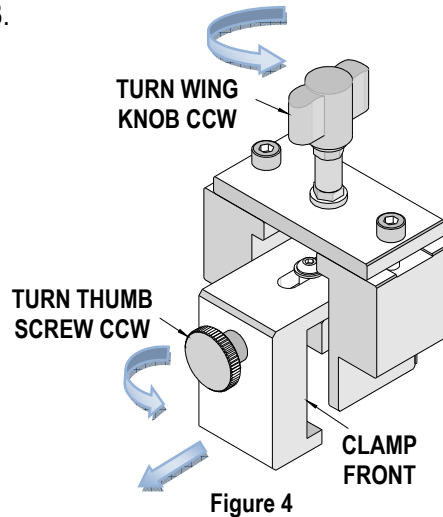

Figure 4

2. Turn the thumb screw counter clockwise so the clamp front can slide forward shown in Figure 4.
3. Position the extractor tool over the outside walls of the Daughtercard module. See figure 5.

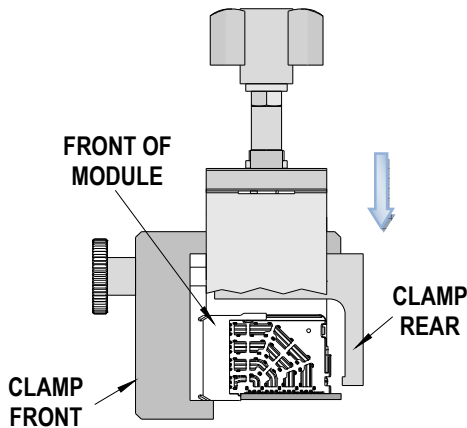

Figure 5

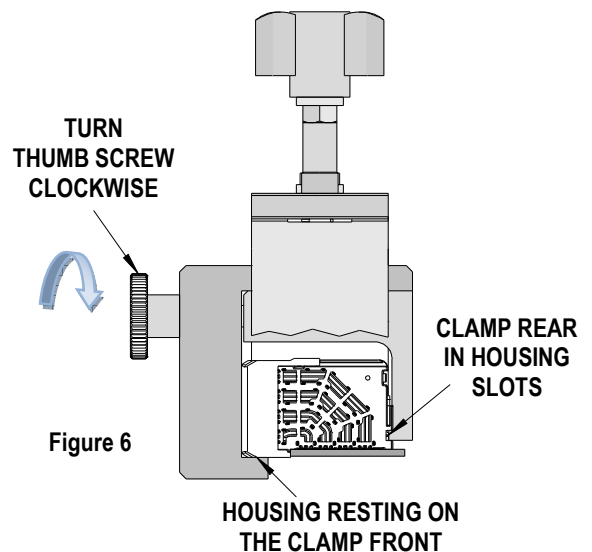

Figure 6

Impel Daughtercard Removal Tool

4. Slide the clamp front onto the bottom lip of the front module by turning the thumb screw clockwise. See Figure 6.
5. Continue turning the thumb screw until the clamp rear is pulled into position and is seated in the recessed slots of the Daughtercard.
6. Make sure the clamp front and rear are in position before lifting the Daughtercard module off the PCB.
7. Turn the wing knob clockwise (CW) until the extension pads contact the printed circuit board. See Figure 7.
8. Continue turning the wing knob clockwise (CW) until the Daughtercard module is removed from the printed circuit board.
9. Move the extraction tool away from the printed circuit board. Turn the wing knob counter-clockwise (CCW) and turn the thumb screw counterclockwise (CCW) to release the module from the extractor tool. Discard the module.

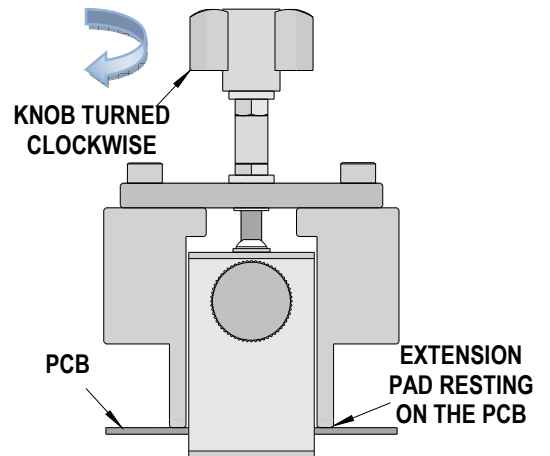

Figure 7

**Daughtercard Module Assembly Removal (With Module Assemblies on one side)**

When Daughtercard modules are stacked end to end on one side the extractor tool can be converted to allow the removal of the desired daughtercard module.

1. Remove the M5 x 14 long SHCS on the side where the extra module is located. See Figure 8.
2. Rotate the extension pad 180°.
3. Reinstall the M5 x 14 long SHCS thru the hole near the end of the C-frame.
4. Follow the tool operation for removal.

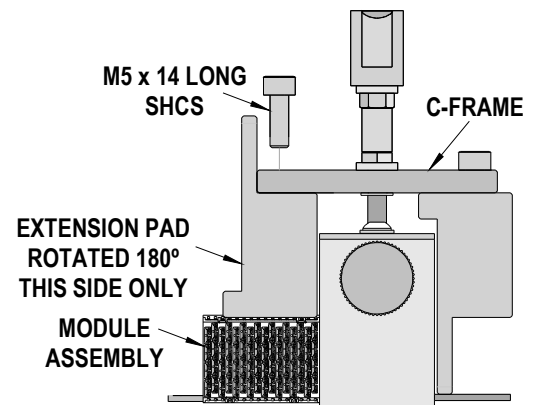

Figure 8

**Daughtercard Module Assembly Removal (With Module Assemblies on both sides)**

When Daughtercard modules are stacked end to end on both sides the extractor tool can be converted to allow the removal of the desired daughtercard module.

1. Remove the M5 x 14 long SHCS on each the side where the extra modules are located. See Figure 9.
2. Rotate the extension pads 180°.
3. Reinstall the M5 x 14 long SHCS thru the hole near the end of the C-frame.
4. Follow the tool operation for removal.

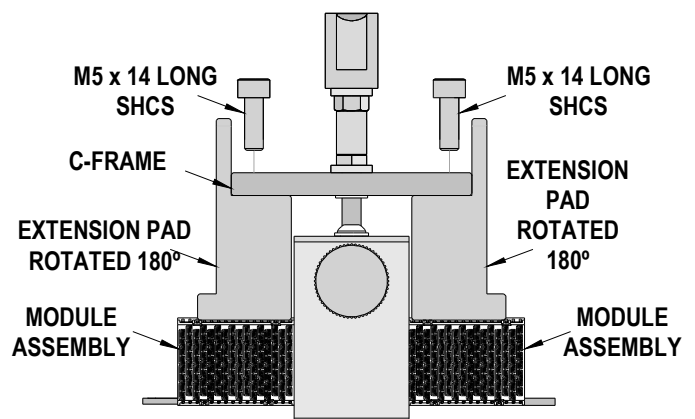

Figure 9

Impel Daughtercard Removal Tool

**Daughtercard Guided Module Assembly Removal**

When removing a Daughtercard with a Guide module the extractor tool can be converted as follows:

1. Remove the M5 x 14 long SHCS on the side where the guide module is located.
2. Move the extension pad out on this side. See Figure 10.
3. Align the second threaded hole in the extension pad with the C-frame.
4. Reinstall the M5 x 14 long SHCS thru the hole near the end of the C-frame.

**NOTE:** Remove the screw holding the guide module to the PCB before removing the Daughtercard module.

5. Follow the tool operation for removal.

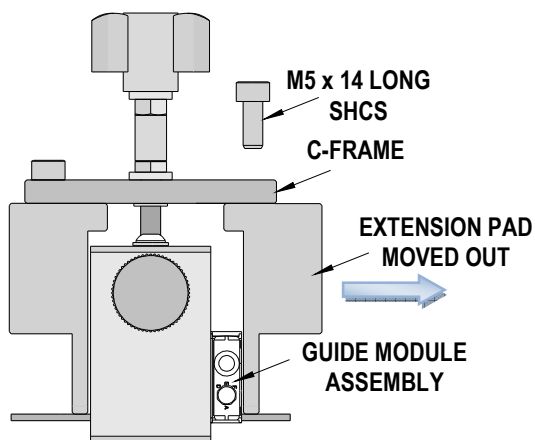

Figure 10

**Maintenance**

It is recommended that each operator of the tool be made aware of, and responsible for, the following maintenance steps:

1. Remove dust, moisture, and other contaminants with a clean brush, or soft, lint free cloth.
2. Do not use any abrasive materials that could damage the tool.
3. Make certain all pins; pivot points and bearing surfaces are protected with a thin coat of high quality machine oil. Do not oil excessively.
4. When tool is not in use, store in a clean, dry area.

**CAUTION:** Molex specifications are valid only when used with Molex terminals, applicators and tooling.

**Contact Information**

For more information on Molex application tooling please contact Molex at 1-800-786-6539.

Visit our Web site at <http://www.molex.com>