

Excellent Integrated System Limited

Stocking Distributor

Click to view price, real time Inventory, Delivery & Lifecycle Information:

[Molex Connector Corporation](#)
[0622024900](#)

For any questions, you can email us directly:

sales@integrated-circuit.com

Removal Tool for I-PASS™ ZHD Wafer Housing Assembly

I-PASS™ zHD Wafer Assembly Removal Tool	molex®	
	Application Tooling Specification Sheet	

FEATURES

- Used in the removal of the I-PASS™ zHD wafer assembly from a PCB
- Removes wafer assemblies from the PCB without damage to the board
- Use tool 62202-4800 to remove the housing assembly before removing the wafer assembly for 170729-0005 ONLY. (See Warnings below)

SCOPE

Products: I-PASS™ zHD Wafer Assembly. See Product List below for specific application tools.



Product List

The following is a partial list of the product order numbers and their specifications this tool is designed to run. Updates to this list are available on www.molex.com.

Series No.	Assembly Order Number			
170729	170729-0001	170729-0002	170729-0004	170729-0005

DESCRIPTION

The tool is used for removal of the I-PASS™ zHD wafer assembly in the Vertical housing assembly from a PCB. The principal parts of the terminal removal tool are shown in Figure 1.

-  **Warning:** For the 170729-0005 the housing assembly tool has to be removed with the vertical housing tool 62202-4800. See ATS-622024800 for more information.
-  **Warning:** For the 170729-0001, 170729-0002, and 170729-0004 remove the guide frame from the housing and use a standard pliers to pull the housing off the wafer.

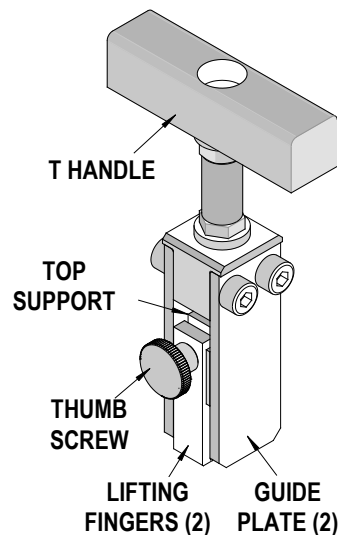

Figure 1

Removal Tool for I-PASS™ ZHD Wafer Housing Assembly

Operation

Note: Be sure that all parts of the removal tool will clear any components on the printed circuit board during use. Tape may also be placed over circuit traces or on the bottom of the PC board Support Plate for added protection of the printed circuit board.

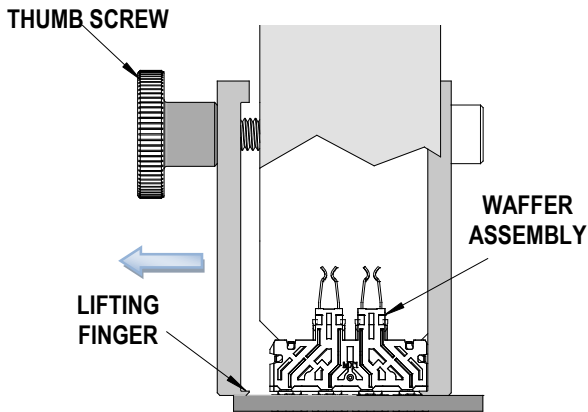

Figure 2

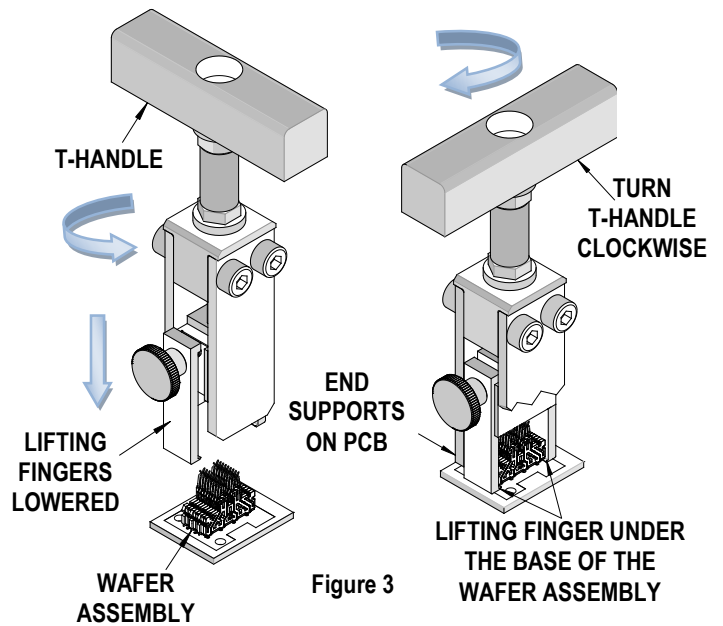

Figure 3

1. Turn the T Handle counter-clockwise (CCW) until the lifting fingers are exposed below the guide plates.
2. Turn the thumb screw counter-clockwise (CCW) so the lifting finger can be adjusted to fit over the wafer assembly. See Figure 2. Once the lifting fingers are over the wafer turn the thumb screw clockwise (CW) until both lifting fingers are securely under the wafer. See Figure 3.

Note: The lifting fingers must snap under the wafer on each side of the assembly so it can be lifted off the printed circuit board.

3. Turn the handle clockwise (CW) until the bottom of the end supports contact the board surface.
4. Continue turning the T handle clockwise (CW) until the wafer assembly is removed from the PCB. See Figure 4.
5. With the removal tool away from the PCB, take the wafer assembly out of the tool by turning the T handle counterclockwise until the lifting fingers are exposed. Loosen the thumb screw enough so all the wafers can be removed. See Figure 3. Pull the wafer assembly up slightly and slide it out of the side of the tool.

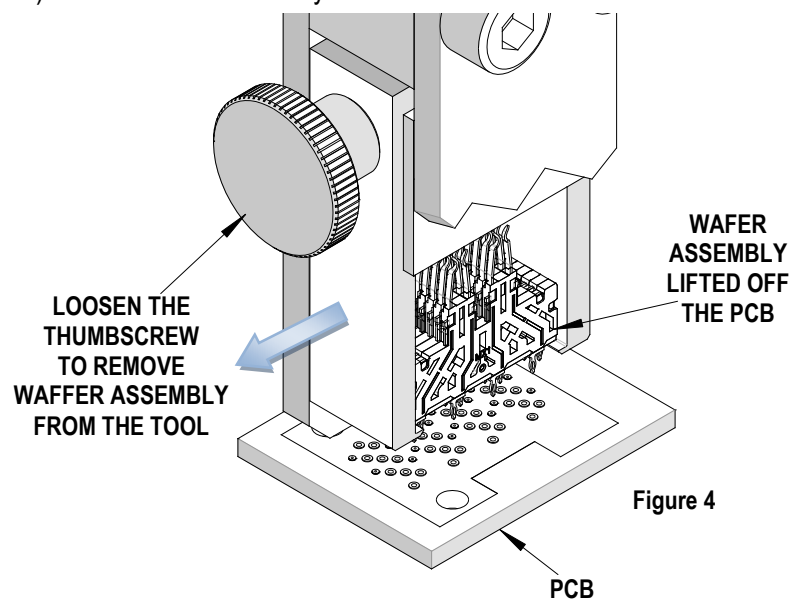

Figure 4



CAUTION: Molex specifications are valid only when used with Molex terminals, applicators and tooling.

Removal Tool for I-PASS™ ZHD Wafer Housing Assembly

Maintenance

It is recommended that each operator of the tool be made aware of, and responsible for, the following maintenance steps:

1. Remove dust, moisture, and other contaminants with a clean brush, or soft, lint free cloth.
2. Do not use any abrasive materials that could damage the tool.
3. Make certain all pins; pivot points and bearing surfaces are protected with a thin coat of high quality machine oil. Do not oil excessively.
4. When tool is not in use, store in a clean, dry area.

Visit our Web site at <http://www.molex.com>