

## Excellent Integrated System Limited

Stocking Distributor

Click to view price, real time Inventory, Delivery & Lifecycle Information:

[Molex Connector Corporation](#)  
[0638242900](#)

For any questions, you can email us directly:

[sales@integrated-circuit.com](mailto:sales@integrated-circuit.com)

Extractor Tool for 1.2mm In Line Crimp Terminals

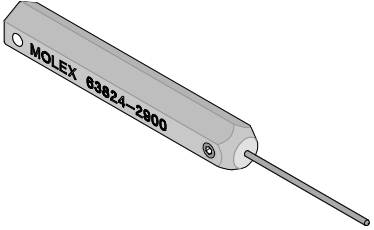
<b>Extractor Tool</b>		
	<b>Application Tooling Specification Sheet</b>	

**FEATURES**

- The 63824-2900 Extraction Tool is for the removal of crimp male terminals from housing series 34899

**SCOPE**

Products: 1.2mm Inline cable sealed 1 by 2 male blade crimped housing assemblies.

Housing Series No.	Housing Order No.			
34899	34899-2010	34899-2011	34899-6010	34899-6011

**DESCRIPTION:**

This extractor tool is 71.00 mm (2.80 in.) long by 6.35mm (.25 in.) diameter, and weight about 0.03kg (1 oz.).

**OPERATION:**

When removing a damaged crimped terminal from the 1.2mm sealed housing follow the steps below:

1. Position the extraction tool blade into the small hole (in line with the terminal to be removed) in the front face of the housing. See Figure 1.

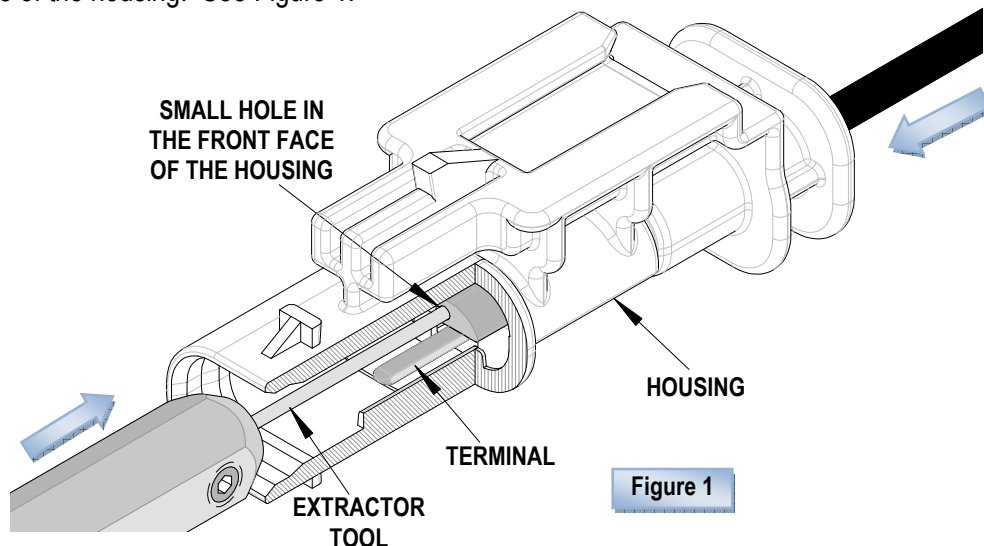

2. Push the crimped wire forward in the arrow direction before using the Extractor Tool.

Extractor Tool for 1.2mm In Line Crimp Terminals

3. Continue to push the extractor tool into the small hole until it clicks or comes to a stop.
4. This should separate the latch from the terminal. Do not force the extractor tool any farther, otherwise it may damage the housing.
5. Holding the extractor tool against the housing, gently pull the crimped wire out of the connector. See Figure 2.

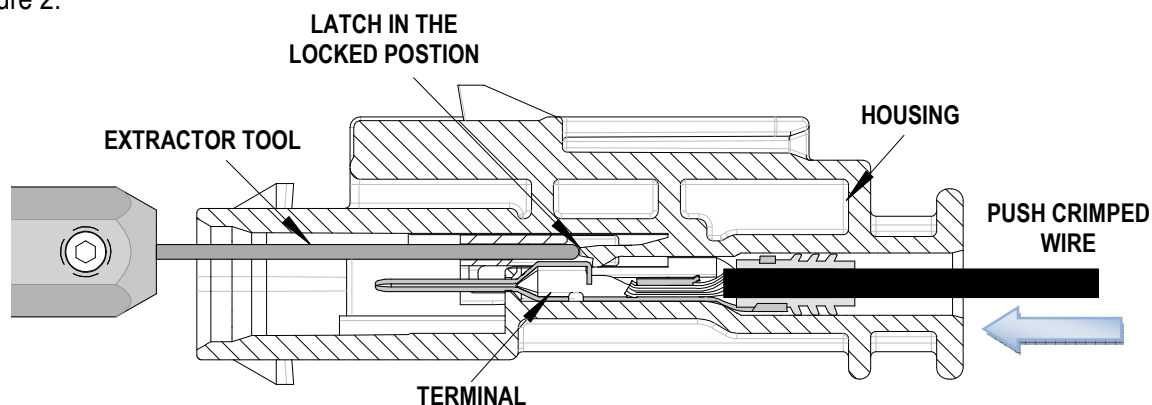

**Figure 2**

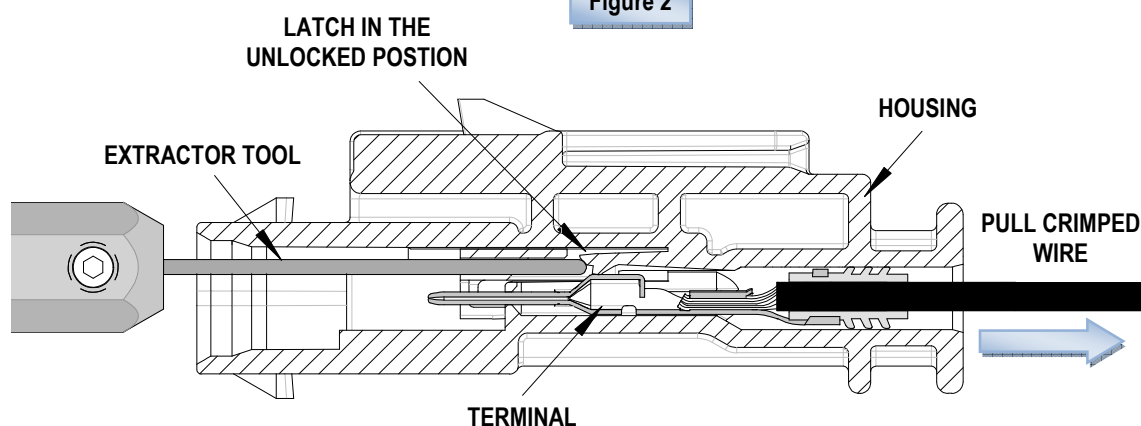

**CAUTION:** This extractor tool should be used to extract the terminal only. Using it for unintended purposes may cause injury or damage to parts. Be careful not to deform the end of the terminal.

**CAUTION:** Molex specifications are valid only when used with Molex terminals, applicators and tooling.

Molex does not offer repair parts for Extractor Tools due to the inexpensive nature of these tools.

**Contact Information**

For more information on Molex application tooling please contact Molex at 1-800-786-6539.

Visit our Web site at <http://www.molex.com>