



**Distributor of Amphenol Commercial Products: Excellent Integrated System Limited**  
Datasheet of L717TWA11W1P - D-Sub Connector Plug, Male Pins 11 (10 + 1 Power) Position  
Free Hanging (In-Line) Solder Cup

Contact us: [sales@integrated-circuit.com](mailto:sales@integrated-circuit.com) Website: [www.integrated-circuit.com](http://www.integrated-circuit.com)

---

## **Excellent Integrated System Limited**

Stocking Distributor

Click to view price, real time Inventory, Delivery & Lifecycle Information:

[Amphenol Commercial Products](#)  
[L717TWA11W1P](#)

For any questions, you can email us directly:

[sales@integrated-circuit.com](mailto:sales@integrated-circuit.com)



# TW

## Hybrid D'Sub series

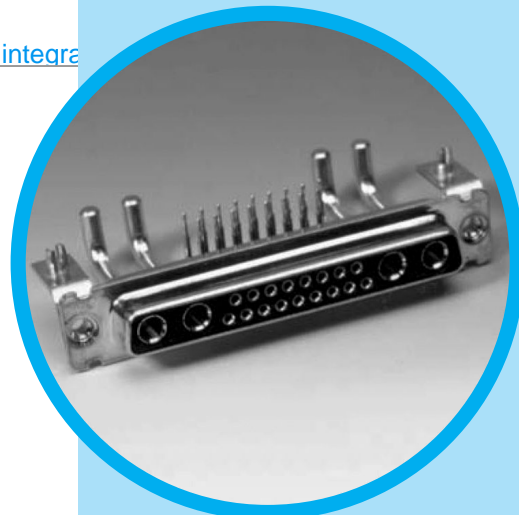

CONTENT

### Specifications

- Connectors according to: MIL C24308 - NFC93425 - HE507

Materials and platings		Electrical Data	
<b>Shells</b>	Steel-Tin plating	<b>Current rating</b>	
<b>Insulators</b>	High temperature black thermoplastic	<b>Signal contacts</b>	7.5 A. with 10 A. peaks
<b>Signal contacts</b>	Female: machined bronze	<b>Power contacts</b>	
<b>Material</b>	Male: machined brass	<b>PCB terminations</b>	10 to 40 A.
<b>Plating finish</b>	16µ "Au over 79µ" Ni min.	<b>Solder cup terminations</b>	10 to 40 A.
<b>Or</b>	30µ "Au over 79µ" Ni min.	<b>Crimp terminations</b>	10 to 40 A.
<b>Shielded contacts</b>	Female: machined bronze	<b>Shielded contacts</b>	0.5 A.
<b>Material</b>	Male: machined brass	<b>Voltage rating</b>	
<b>Plating</b>		<b>Signal and power contacts</b>	300 V.R.M.S. at 50 Hz
<b>Inner conductor</b>	16µ "Au or 30µm Au over 79µ" Ni	<b>Shielded contacts</b>	150 V.R.M.S. at 50 Hz
<b>Outer ring</b>	10µ "Au over 79µ" Ni	<b>Shielded contacts</b>	
<b>Terminations</b>	Tinned	<b>Frequency range</b>	0-1 GHz
<b>Except solder cup and crimp terminations</b>	gold flash	<b>Attenuation</b>	0.2dB
<b>Power contacts</b>	Female: machined bronze	<b>V. S. W. R.</b>	1.4(+0.04/GHz)
<b>Material</b>	Male: machined brass	<b>Characteristic impedance</b>	50 Ohms
<b>Plating</b>		<b>Dielectric withstanding voltage</b>	≥ 1000 V.R.M.S. at 50Hz
<b>Contacts</b>	16µ "Au or 30µ" Au over 79µ" Ni	<b>Insulation resistance</b>	≥ 5000 M Ohms at 500 VDC
<b>Terminations</b>	Tinned	<b>Contact resistance</b>	≤ 5m Ohms
<b>Except solder cup and crimp terminations</b>	gold flash	<b>Shell resistance (electrical grounding)</b>	≤ 1m Ohm
<b>Brackets</b>	Steel-Tin plating		
<b>Front jackscrews</b>	Brass-Tin plating		
<b>Rear clinch nuts</b>	Brass-Tin plating		
<b>Boardlocks</b>	Bronze-Tin plating		
<b>Stand-off</b>	Brass-Tin plating		

Climatic Data		Mechanical data	
<b>Operating temperature</b>	-55°C + 155°C (with peaks up to 180°C)	<b>Shells</b>	With or without dimples
<b>Damp heat</b>	56 days (40°C - 95% HR)	<b>Contact retention force in dielectric material</b>	> 40N
<b>Salt spray</b>	48 hours	<b>Maximum mating and unmating force</b>	
		<b>With dimples</b>	E size = 70 N A size = 80 N B size = 100 N C size = 150 N D size = 180 N
		<b>Without dimples</b>	E size = 30 N A size = 50 N B size = 80 N C size = 120 N D size = 160 N
		<b>Compatible with process</b>	
		<b>IR - Air convectioned</b>	260° for 20 s.
		<b>Resistance to solder iron heat</b>	260°C for 30 s.
		<b>Mating cycles</b>	≥ 200 (classe II) or 500 (classe I)
		<b>Blind mating system</b>	Available upon request
		<b>Polarization</b>	Available with locking accessories Consult factory



DESCRIPTION

Amphenol D'Sub TW Hybrid Series permits a mix of contacts including signal, power, shielded, high voltage and fiber optics in the same housing with 18 different contacts arrangements.

This economic series was first developed from our military series, and has improved features:

- new contacts
- new high temperature black thermoplastic insert
- PCB configurations come preloaded with fixed contacts and brackets.

These connectors are supplied with screw machined contacts which are fixed in the insulator.

A complete range of housings are also available for cable application.

*A full range of arrangements compatible with reflow process*

APPLICATIONS

- Commercial
- Medical
- Industrial
- Telecom
- Any application requiring optimization of space

TW / E1



## Shell and contacts plating

### CLASS II

0.4µm (16µ") Au contacts gold plating  
 200 mating cycles

Types	Shells and plating
77 TW	Tin plated shell *Male and female
717 TW	Tin plated shell with dimples Male only

### CLASS I

0.76µm (30µ") Au contacts gold plating  
 500 mating cycles

Types	Shells and plating
177 TW	Tin plated shell *Male and female
777 TW	Tin plated shell with dimples Male only

## Housing arrangements

### Male front view

Arrangement ..... Shell size .....	 5W1 E	 7W2 A	 11W1 A
Arrangement ..... Shell size .....	 3W3 A	 5W5 B	 9W4 B
Arrangement ..... Shell size .....	 13W3 B	 17W2 B	 21W1 B
Arrangement ..... Shell size .....	 27W2 C	 13W6 C	 17W5 C
Arrangement ..... Shell size .....	 21W4 C	 8W8 C	 25W3 C
Arrangement ..... Shell size .....	 24W7 D	 36W4 D	 43W2 D

## Shell size dimensions

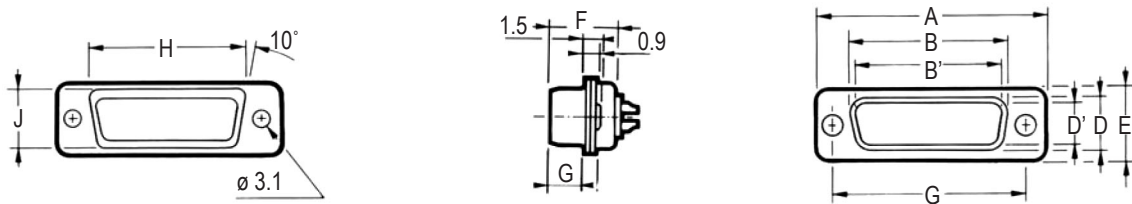

Shell size	Contact P: Pin S: Socket	A ±0.25 (±.010)	B 0/-0.20 (0/-0.008)	B' +0.20/0 (+.008/0)	C ±0.10 (±.004)	D 0/-0.25 (0/-0.010)	D' +0.25/0 (+.010/0)	E ±0.20 (±.008)	F +0.05/-0.20 (+.002/-0.008)	F' +0.10/-0.20 (+.004/-0.008)	G +0.10/-0.20 (+.004/-0.008)	G' ±0.10 (±.004)	H +0.10/-0.40 (+.004/-0.016)	J 0/-0.50 (0/-0.020)
E	P	30.7 (1.209")		16.8 (.661")	25.0 (.984")		8.2 (.323")	12.4 (.488")		10.9 (.429")		5.9 (.232")	19.4 (.764")	11.0 (.433")
	S		16.4 (.646")			8.0 (.315")		11.1 (.437")		6.2 (.244")				
A	P	39.0 (1.535")		25.1 (.988")	33.3 (1.311")		8.2 (.323")	12.4 (.488")		10.9 (.429")		5.9 (.232")	27.7 (1.091")	11.0 (.433")
	S		24.8 (.976")			8.0 (.315")		11.1 (.437")		6.2 (.244")				
B	P	52.9 (2.083")		38.8 (1.528")	47.0 (1.850")		8.2 (.323")	12.4 (.488")		11.0 (.433")		5.8 (.228")	41.4 (1.630")	11.0 (.433")
	S		38.5 (1.513")			8.0 (.315")		11.1 (.437")		6.2 (.244")				
C	P	69.2 (2.724")		55.3 (2.177")	63.5 (2.500")		8.2 (.323")	12.4 (.488")		11.0 (.433")		5.8 (.228")	57.9 (2.280")	11.0 (.433")
	S		54.9 (2.161")			8.0 (.315")		11.1 (.437")		6.2 (.244")				
D	P	66.8 (2.630")		52.7 (2.075")	61.1 (2.406")		11.0 (.433")	15.2 (.598")		11.0 (.433")		5.8 (.228")	55.5 (2.185")	13.8 (.543")
	S		52.5 (2.067")			10.9 (.429")		11.1 (.437")		6.2 (.244")				

## Panel cutouts

Optimal cutout for rear mounting

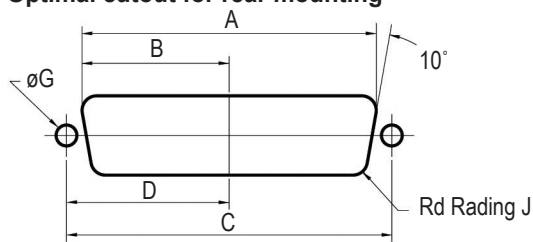

Standard cutout

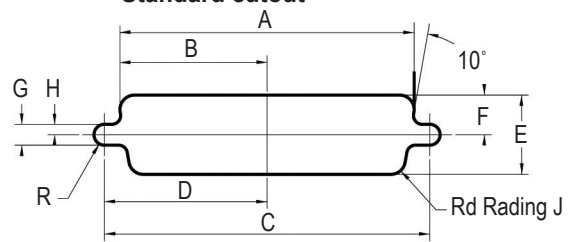

Shell size	Mounting method	A ±0.20 (±.008)	B ±0.20 (±.008)	C ±0.20 (±.008)	D ±0.20 (±.008)	E ±0.20 (±.008)	F ±0.20 (±.008)	G ±0.20 (±.008)	H ±0.20 (±.008)	J ±0.20 (±.008)
E	Front	22.2 (.874")	11.1 (.437")	25.0 (.984")	12.5 (.492")	13.0 (.512")	6.5 (.256")	3.0 (.118")	1.5 (.059")	2.1 (.083")
	Rear	20.5 (.807")	10.2 (.402")							3.4 (.134")
A	Front	30.5 (1.201")	15.3 (.602")	33.3 (1.311")	16.7 (.657")	13.0 (.512")	6.5 (.256")	3.0 (.118")	1.5 (.059")	2.1 (.083")
	Rear	28.8 (1.134")	14.4 (.567")							3.4 (.134")
B	Front	44.3 (1.744")	22.1 (.870")	47.0 (1.850")	23.5 (.925")	13.0 (.512")	6.5 (.256")	3.0 (.118")	1.5 (.059")	2.1 (.083")
	Rear	42.5 (1.673")	21.3 (.839")							3.4 (.134")
C	Front	60.7 (2.390")	30.4 (1.197")	63.5 (2.500")	31.7 (1.248")	13.0 (.512")	6.5 (.256")	3.0 (.118")	1.5 (.059")	2.1 (.083")
	Rear	59.1 (2.327")	29.5 (1.161")							3.4 (.134")
D	Front	58.3 (2.295")	29.2 (1.150")	61.1 (2.406")	30.6 (1.205")	15.8 (.622")	7.9 (.311")	3.0 (.118")	1.5 (.059")	2.1 (.083")
	Rear	56.3 (2.217")	28.2 (1.110")							3.4 (.134")

## Straight connector footprint

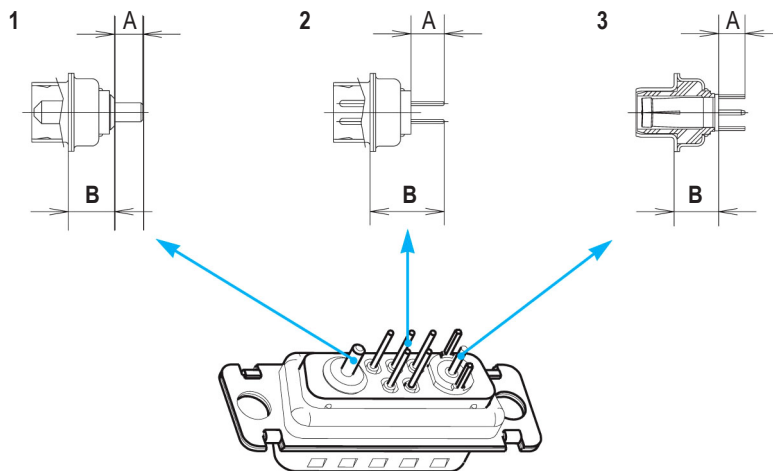

Signal tail 0.6 mm Dia. (.0236")  
 1.6 mm (.063")PCB  
 For other PCB thickness: consult factory.

Description		Dimensions	
		a	b
Power (.126" tail dia.)	1	4.80 mm (.198")	7.2 mm (.283")
Power (.0787" tail dia.)	1	4.80 mm (.198")	7.2 mm (.283")
Shielded	3	4.00 mm (.157")	7.2 mm (.283")
Signal	2	5.00 mm (.196")	11.50 mm (.453")

## Straight contact combinations

### Arrangement with signal contacts

See above dimensions	<b>Size 8 and 20 Contacts</b>
<b>P 3SY</b>	Power 3.2 mm DIA. (.126") (20 to 40 A) and signal
<b>P 2SY</b>	Power 2 mm DIA. (.0787") (10 to 20 A) and signal
<b>CSY</b>	Shielded and signal
<b>SY</b>	Signal only
No reference	Signal (Size 20) with solder cup terminations Housing preloaded with contacts

### Arrangement without signal contacts 3W3 - 5W5 - 8W8

See above dimensions	<b>Size 8 Contacts</b>
<b>P 3Y</b>	Power only 3.2 mm DIA. (.126") (20 to 40 A)
<b>P 2Y</b>	Power only 2 mm DIA. (.0787") (10 to 20 A)
<b>CY</b>	Shielded only

## Right angle connector footprint

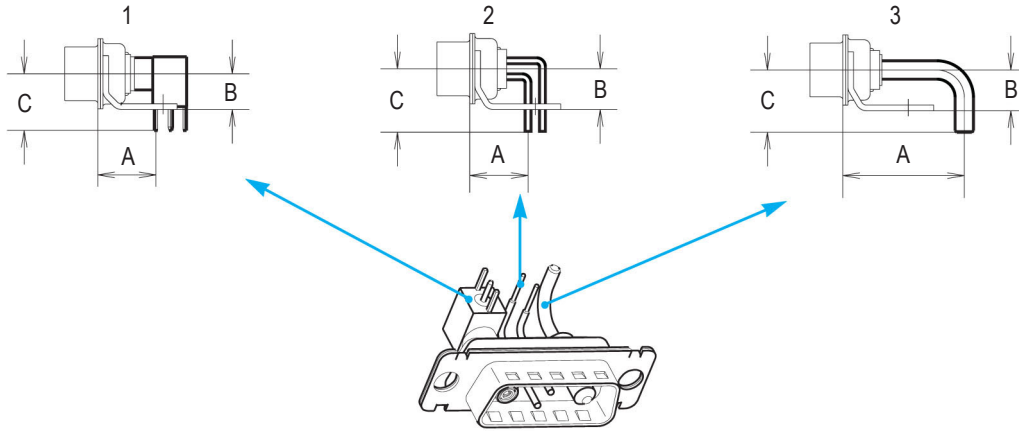

Signal tail 0.6 mm Dia. (.0236")  
 1.6 mm (.063") PCB  
 For other PCB thickness: consult factory.

Description	Europe			Mix			MIL			
	a	b	c	a	b	c	a	b	c	
Shielded	1	-	-	-	-	-	-	-	-	
Signal	2	10.30mm (.406")	7.20mm (.283")	11.20mm (.441")	10.30mm (.406")	6.30mm (.248")	9.50mm (.374")	8.10mm (.319")	6.30mm (.248")	9.50mm (.374")
Power (.0787" tail dia.)	3	11.57mm (.456")	7.20mm (.283")	10.50mm (.413")	11.57mm (.456")	6.30mm (.248")	9.50mm (.374")	9.52mm (.375")	6.30mm (.248")	9.50mm (.374")
Power (.126" tail dia.)	3	21.46mm (.845")	7.20mm (.283")	10.50mm (.413")	21.46mm (.845")	6.30mm (.248")	9.50mm (.374")	21.46mm (.845")	6.30mm (.248")	9.50mm (.374")

Note: above dimensions correspond to sizes E to C. Consult factory for D sizes.  
 Connector comes equipped with contacts and brackets.

## Right angle contacts combinations

### Arrangement with signal contacts

European footprint	Mixed footprint	MIL (U.S.) footprint	Size 8 and 20 Contacts
EP3SV	HP3SV	MP3SV	Power 3.2 mm DIA. (.126") (20 to 40 A) and signal
EP2SV	HP2SV	MP2SV	Power 2 mm DIA. (.0787") (10 to 20 A) and signal
-	HCSV	MCSV	Shielded and signal
ESV	HSV	MSV	Signal only

### Arrangement without signal contacts 3W3 - 5W5 - 8W8

European footprint	Mixed footprint	MIL (U.S.) footprint	Size 8 contacts only
EP3V	HP3V	MP3V	Power only 3.2 mm DIA. (.126") (20 to 40 A)
EP2V	HP2V	MP2V	Power only 2.0 mm DIA. (.0787") (10 to 20 A)
-	HCV	MCV	Shielded only

## Mounting options

### Right angle version

Connectors come equipped with metal brackets

**BLANK:** 3.10mm (.122") dia mounting hole

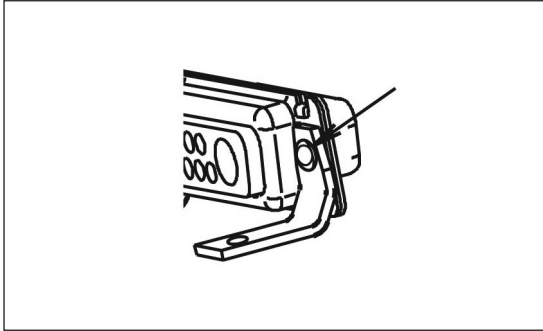

**RM6:** metal brackets + boardlock

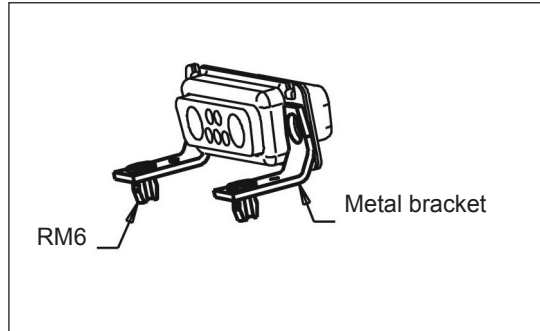

### Straight version

**BLANK:** 3.10mm (.122") dia mounting hole

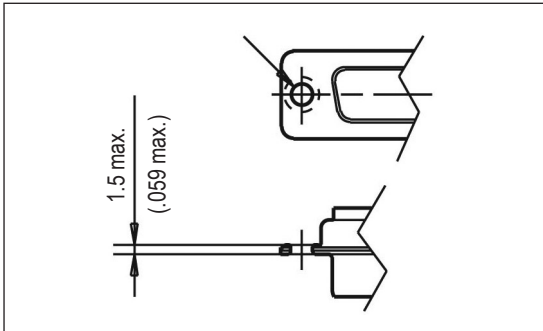

**RM54:** RM5 4.40 threaded

**RM53:** RM5 M3 threaded

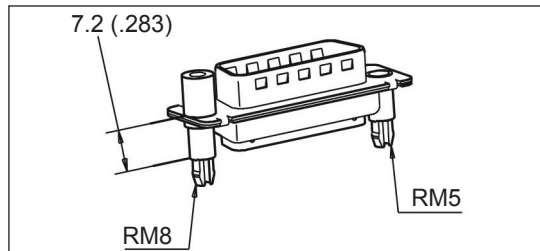

**RM84:** RM8 4.40 threaded

**RM83:** RM8 M3 threaded

**A514:** blind mating system

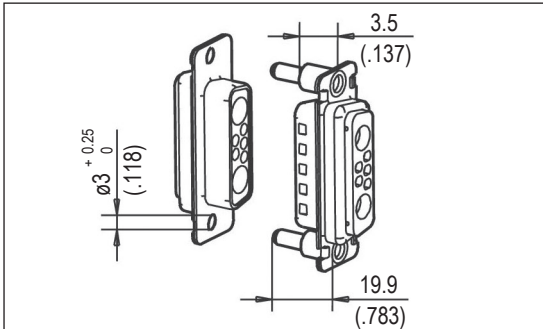

**FM:** float mounting system

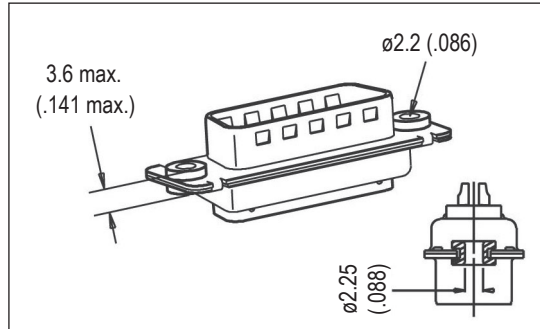

### Straight and right angle version

**4R:** 4.40 rear nut

**3R:** M3 rear nut

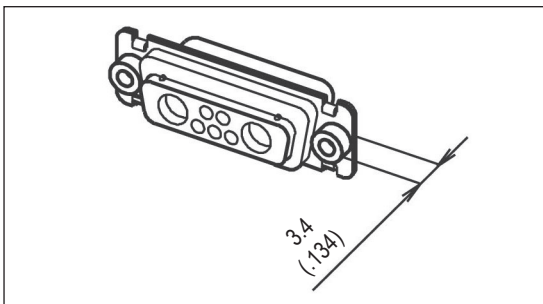

**4F:** 4.40 front female screwlock

**3F:** M3 front female screwlock

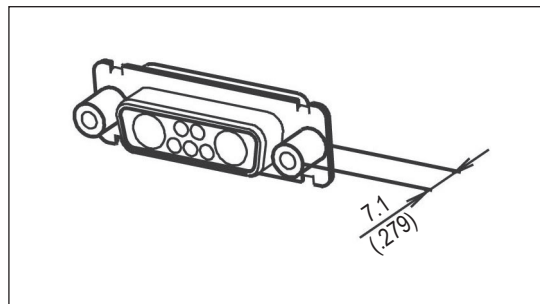

## High power contacts

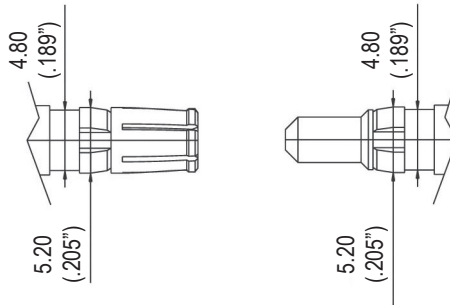

## Solder cup version

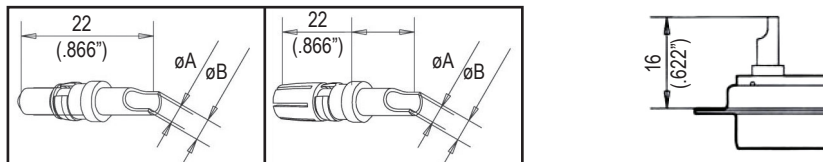

Plug	P/N	Socket	Current	Dimensions	
				A mm (inch)	B mm (inch)
L 17DM 53745-8	L 17DM 53744-7	L 17DM 53744-7	10 to 20 Amp.	1.80 (.071")	2.55 (.100")
L 17DM 53745-7	L 17DM 53744-6	L 17DM 53744-6	20 to 30 Amp.	2.80 (.110")	3.70 (.145")
L 17DM 53745-1	L 17DM 53744-1	L 17DM 53744-1	30 to 40 Amp.	4.80 (.189")	5.60 (.220")

Trim dimensions: 7.5 mm (.295")

## Crimp version

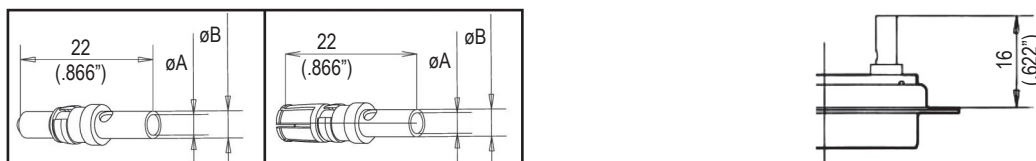

Plug	P/N	Socket	Current	Dimensions	
				A mm (inch)	B mm (inch)
L 17DM 53745-208	L 17DM 53744-207	L 17DM 53744-207	10 to 20 Amp.	1.80 (.071")	2.55 (.100")
L 17DM 53745-207	L 17DM 53744-206	L 17DM 53744-206	20 to 30 Amp.	2.80 (.110")	3.70 (.145")
L 17DM 53745-201	L 17DM 53744-201	L 17DM 53744-201	30 to 40 Amp.	4.80 (.189")	5.60 (.220")

Trim dimensions: 7.5 mm (.295")

**Crimping tool for all sizes  
L17D479SP**



**Extraction tool for sizes 8 cts**



## Straight shielded contacts

### Crimp ferrule and inner solder

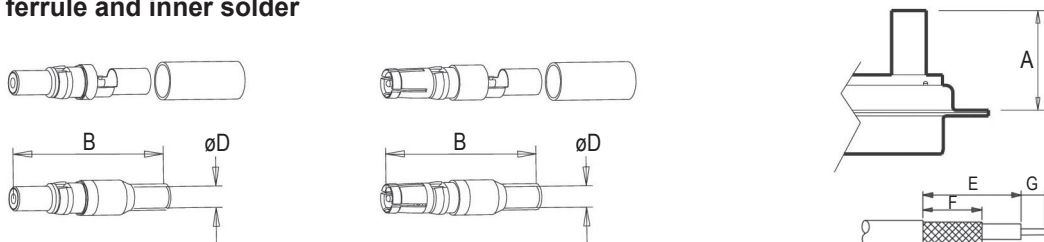

Type	P/N	Dimensions (inch)			Cable - RG	Trim dimensions (inch)		
		A Max	B	D		E	F	G
plug	L17DM 53740	18.8 (740")	23.6 (.929")	1.0 (.039")	178 B/U	7.9 (.311")	6.3 (.248")	2 (.078")
plug	L17DM 53740-1	18.8 (740")	23.6 (.929")	1.7 (.066")	179 B/U 316 B/U	7.9 (.311")	6.3 (.248")	2 (.078")
plug	L17DM 53740-3	21.5 (846")	23.6 (.929")	2.8 (.110")	180 B/U	9.5 (.374")	7.9 (.311")	2 (.078")
plug	L17DM 53740-5	21.5 (846")	23.6 (.929")	3.2 (.126")	58 C/U	9.5 (.374")	7.9 (.311")	2 (.078")
socket	L17DM 53742	18.8 (740")	23.6 (.929")	1.0 (.039")	178 B/U	7.9 (.311")	6.3 (.248")	2 (.078")
socket	L17DM 53742-1	18.8 (740")	23.6 (.929")	1.7 (.066")	179 B/U 316 B/U	7.9 (.311")	6.3 (.248")	2 (.078")
socket	L17DM 53742-3	21.5 (846")	23.6 (.929")	2.8 (.110")	180 B/U	9.5 (.374")	7.9 (.311")	2 (.078")
socket	L17DM 53742-5	21.5 (846")	23.6 (.929")	3.2 (.126")	58 C/U	9.5 (.374")	7.9 (.311")	2 (.078")

### Ferrule and inner solder

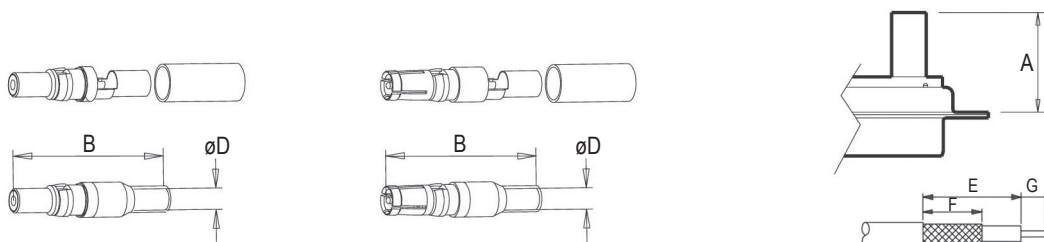

Type	P/N	Dimensions (inch)			Cable - RG	Trim dimensions (inch)		
		A Max	B	D		E	F	G
short plug	L17DM 53740-5000	17.0 (669")	21.8 (.858")	1.0 (.039")	178 B/U	7.9 (.311")	6.3 (.248")	2 (.078")
plug	L17DM 53740-5001	18.8 (740")	23.6 (.929")	1.7 (.066")	179 B/U 316 B/U	7.9 (.311")	6.3 (.248")	2 (.078")
plug	L17DM 53740-5002	21.5 (846")	26.3 (1.035")	2.8 (.110")	180 B/U	9.5 (.374")	7.9 (.311")	2 (.078")
plug	L17DM 53740-5005	21.5 (846")	26.3 (1.035")	3.2 (.126")	58 C/U	9.5 (.374")	7.9 (.311")	2 (.078")
plug	L17DM 53740-5008	18.8 (740")	23.6 (.929")	1.0 (.039")	178 B/U	7.9 (.311")	6.3 (.248")	2 (.078")
short socket	L17DM 53742-5000	17.0 (669")	21.8 (.858")	1.0 (.039")	178 B/U	7.9 (.311")	6.3 (.248")	2 (.078")
socket	L17DM 53742-5001	18.8 (740")	23.6 (.929")	1.7 (.066")	179 B/U 316 B/U	7.9 (.311")	6.3 (.248")	2 (.078")
socket	L17DM 53742-5002	21.5 (846")	26.3 (1.035")	2.8 (.110")	180 B/U	9.5 (.374")	7.9 (.311")	2 (.078")
socket	L17DM 53742-5004	21.5 (846")	26.3 (1.035")	3.2 (.126")	58 C/U	9.5 (.374")	7.9 (.311")	2 (.078")
socket	L17DM 53742-50060	18.8 (740")	23.6 (.929")	1.0 (.039")	178 B/U	7.9 (.311")	6.3 (.248")	2 (.078")

## Right angled shielded contact

### Crimp ferrule and inner solder

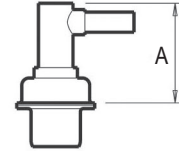
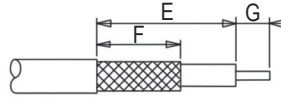
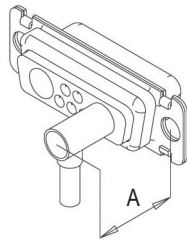

Type	P/N	Dimensions (inch)			Cable - RG	Trim dimensions (inch)		
		A Max	B	D		E	F	G
plug	L17DM 53741	13.5 (.531")	18.6 (.732")	1.0 (.039")	178 B/U	9.5 (.374")	5.9 (.232")	1.6 (.062")
plug	L17DM 53741-1	13.5 (.531")	18.6 (.732")	1.7 (.066")	179 B/U 316 B/U	9.5 (.374")	5.9 (.232")	1.6 (.062")
plug	L17DM 53741-3	13.5 (.531")	18.6 (.732")	2.8 (.110")	180 B/U	10.7 (.421")	7.9 (.311")	2.4 (.094")
plug	L17DM 53741-4	13.5 (.531")	18.6 (.732")	3.2 (.126")	58 C/U	10.7 (.421")	7.9 (.311")	2.4 (.094")
socket	L17DM 53743-2	13.5 (.531")	18.6 (.732")	1.0 (.039")	178 B/U	9.5 (.374")	5.9 (.232")	1.6 (.062")
socket	L17DM 53743-3	13.5 (.531")	18.6 (.732")	1.7 (.066")	179 B/U 316 B/U	9.5 (.374")	5.9 (.232")	1.6 (.062")
socket	L17DM 53743-5	13.5 (.531")	18.6 (.732")	2.8 (.110")	180 B/U	10.7 (.421")	7.9 (.311")	2.4 (.094")
socket	L17DM 53743-6	13.5 (.531")	18.6 (.732")	3.2 (.126")	58 C/U	10.7 (.421")	7.9 (.311")	2.4 (.094")

### Ferrule and inner solder

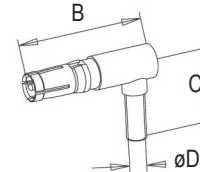
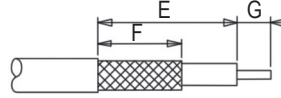
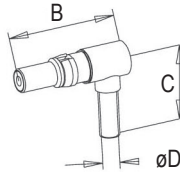

Type	P/N	Dimensions (inch)			Cable - RG	Trim dimensions (inch)		
		A Max	B	D		E	F	G
plug	L17DM 53741-5000	13.5 (.531")	18.6 (.732")	1.0 (.039")	178 B/U	9.5 (.374")	5.9 (.232")	1.6 (.062")
plug	L17DM 53741-5001	13.5 (.531")	18.6 (.732")	1.7 (.066")	179 B/U 316 B/U	9.5 (.374")	5.9 (.232")	1.6 (.062")
plug	L17DM 53741-5003	13.5 (.531")	18.6 (.732")	2.8 (.110")	180 B/U	10.7 (.421")	7.9 (.311")	2.4 (.094")
plug	L17DM 53741-5004	13.5 (.531")	18.6 (.732")	3.2 (.126")	58 C/U	10.7 (.421")	7.9 (.311")	2.4 (.094")
socket	L17DM 53743-5000	13.5 (.531")	18.6 (.732")	1.0 (.039")	178 B/U	9.5 (.374")	5.9 (.232")	1.6 (.062")
socket	L17DM 53743-5001	13.5 (.531")	18.6 (.732")	1.7 (.066")	179 B/U 316 B/U	9.5 (.374")	5.9 (.232")	1.6 (.062")
socket	L17DM 53743-5003	13.5 (.531")	18.6 (.732")	2.8 (.110")	180 B/U	10.7 (.421")	7.9 (.311")	2.4 (.094")
socket	L17DM 53743-5004	13.5 (.531")	18.6 (.732")	3.2 (.126")	58 C/U	10.7 (.421")	7.9 (.311")	2.4 (.094")

## Crimping tool

### Hand crimp tool

227-0944 (without dies) (M 22 520/5-01)

RG cables	MIL reference	Amphenol P/N	dim. between 2 flat surface cavity	
			A	B
RG 58 C/U	M 22 520/5-05	227 1221-05	5.41	-
RG 178 B/U	M 22 520/5-03	227 1221-03	-	2.67
RG 179 B/U	M 22 520/5-03	227 1221-03	3.25	-
RG 180 B/U	M 22 520/5-05	227 1221-05	-	4.52

## Extraction tool

### Extraction tool for sizes 8 cts L17D429SP



## Cabling instructions for shielded contacts

### Straight crimp shielded contacts:

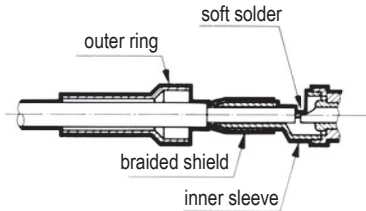

### inner solder contact outer crimp contact

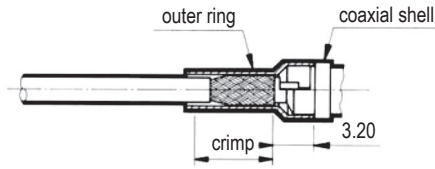

### Right angle crimp shielded contacts:

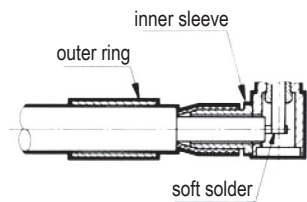

### inner solder contact outer crimp contact

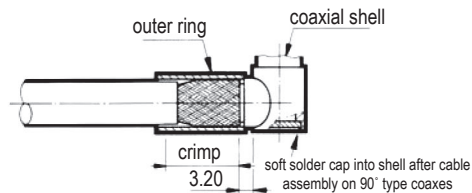

### Assembly method

- Slide the outer ring over the cable jacket. Trim the cable according to the recommended dimensions.
- Insert the cable dielectric and the center conductor inside the inner sleeve.
- Solder the central conductor to the shielded center contacts.
- Slide the outer ring towards the inner sleeve and recover the braid.
- Using crimp hand tool equipped with the appropriate dies, crimp in the area defined.

### Solder straight shielded contacts:

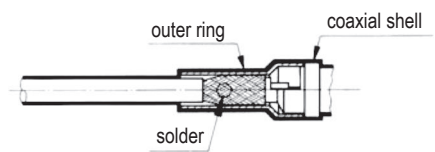
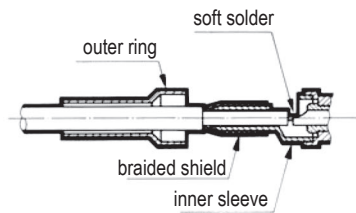

### Solder right angle shielded contacts:

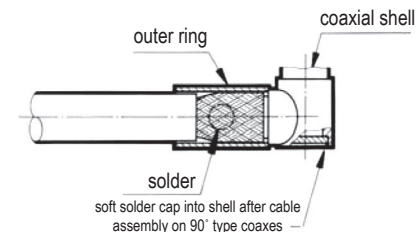
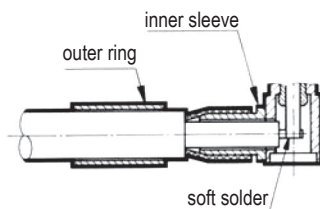

### Assembly method

- Slide the outer ring over the cable jacket. Trim the cable according to the recommended dimensions.
- Insert the cable dielectric and the center conductor inside the inner sleeve.
- Solder the central conductor to the shielded center contacts.
- Slide the outer ring towards the inner sleeve and recover the braid.
- Solder by introducing metal through the outer ring hole.

## How to build your part number

**RoHS Compliant**

Contacts and Shell		
Contact Plating	Shell	
	Tinned	Tinned & Indents; Plug only
0.4µm(16µ") Au	77	717
0.76µm(30µ") Au	177	777

**Shell size and Configuration:**  
 E5W1, A3W3, A7W2, A11W1, B5W5, B9W4, B13W3, B17W2, B21W1, C8W8, C13W6, C17W5, C21WA4, C25W3, C27W2, D24W7, D36W4, D43W2

**Gender:**  
 P: Pin  
 S: Socket

**Special Deviations**  
 Please consult factory

**Board Mounting Options**  
**For Straight**  
**Blank:** .120"(3.05mm) Clear Hole  
**RM53:** M3 Threaded (panel side) standoff with boardlock  
**RM54:** 4-40UNC Threaded (panel side) standoff with boardlock  
**RM84:** Non-Removable M3 screwlock, with standoff and boardlock  
**For Right Angle**  
**RM6:** Metal bracket with boardlocks

**Panel Mounting Options**  
**For right angle & cable mount**  
**Blank:** .120"(3.05mm) Clear Hole  
**3F:** M3 Front Screwlock  
**3R:** M3 Rear Threaded Insert  
**4F:** #4-40 Front Screwlock  
**4R:** #4-40 Threaded Rear Insert  
**FM:** Float mount system  
**A514:** Blind Mate Guide Pin

**Contacts:**

**For straight**  
**BLANK:** Solder-cup signal contacts only  
**P3SY:** 20-40 Amp power & signal mix  
**P2SY:** 10-20 Amp power & signal mix  
**CSY:** Coax & signal mix  
**SY:** Signal only  
**P3Y:** 20-40 Amp power only (3W3, 5W5, 8W8)  
**P2Y:** 10-20 Amp power only (3W3, 5W5, 8W8)  
**CY:** Coax only (3W3, 5W5, 8W8)

**For right angle**  
**MP3SV:** US Footprint, 20-40 Amp power & signal mix  
**MP2SV:** US Footprint, 10-20 Amp power & signal mix  
**MCSV:** US Footprint, Coax & signal mix  
**MSV:** US Footprint, Signal only  
**MP3V:** US Footprint, 20-40 Amp power only (3W3, 5W5, 8W8)  
**MP2V:** US Footprint, 10-20 Amp power only (3W3, 5W5, 8W8)  
**MCV:** US Footprint, Coax only (3W3, 5W5, 8W8)  
**EP3SV:** European Footprint, 20-40 Amp power & signal mix  
**EP2SV:** European Footprint, 10-20 Amp power & signal mix  
**ESV:** European Footprint, Signal only  
**EP3V:** European Footprint, 20-40 Amp power only (3W3, 5W5, 8W8)  
**EP2V:** European Footprint, 10-20 Amp power only (3W3, 5W5, 8W8)  
**HP3SV:** Mixed Footprint, 20-40 Amp power & signal mix  
**HP2SV:** Mixed Footprint, 10-20 Amp power & signal mix  
**HCSV:** Mixed Footprint, Coax & signal mix  
**HSV:** Mixed Footprint, Signal only  
**HP3V:** Mixed Footprint, 20-40 Amp power only (3W3, 5W5, 8W8)  
**HP2V:** Mixed Footprint, 10-20 Amp power only (3W3, 5W5, 8W8)  
**HCV:** Mixed Footprint, Coax only (3W3, 5W5, 8W8)

