

Excellent Integrated System Limited

Stocking Distributor

Click to view price, real time Inventory, Delivery & Lifecycle Information:

[Diodes Incorporated](#)
[ULN2002AS16-13](#)

For any questions, you can email us directly:

sales@integrated-circuit.com



ULN2002A/ ULN2003A/ ULN2004A

**HIGH VOLTAGE, HIGH CURRENT
DARLINGTON TRANSISTOR ARRAYS**

Description

The ULN2002A, ULN2003A and ULN2004A are high voltage, high current Darlington arrays each containing seven open collector common emitter pairs. Each pair is rated at 500mA. Suppression diodes are included for inductive load driving, the inputs and outputs are pinned in opposition to simplify board layout.

Device options are designed to be compatible with common logic families:

- ULN2002A (14-25V PMOS)
- ULN2003A (5V TTL, CMOS)
- ULN2004A (6-15V CMOS, PMOS)

These devices are capable of driving a wide range of loads including solenoids, relays, DC motors, LED displays, filament lamps, thermal print-heads and high-power buffers.

The ULN2002A, 2003A and 2004A are available in both a small outline 16-pin package (SO-16) and DIP-16 package.

Features

- 500mA Rated Collector Current (single output)
- High Voltage Outputs: 50V
- Output Clamp Diodes
- Inputs Compatible with Popular Logic Types
- Relay Driver Applications
- "Green" Molding Compound (No Br, Sb)
- **Totally Lead-Free & Fully RoHS Compliant (Note 1 & 2)**
- **Halogen and Antimony Free. "Green" Device (Note 3)**

Notes: 1. No purposely added lead. Fully EU Directive 2002/95/EC (RoHS) & 2011/65/EU (RoHS 2) compliant.
 2. See http://www.diodes.com/quality/lead_free.html for more information about Diodes Incorporated's definitions of Halogen- and Antimony-free, "Green" and Lead-free.
 3. Halogen- and Antimony-free "Green" products are defined as those which contain <900ppm bromine, <900ppm chlorine (<1500ppm total Br + Cl) and <1000ppm antimony compounds.

Pin Assignments

(Top View)

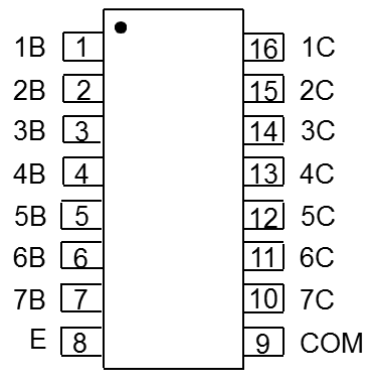

SO-16/DIP-16

Connection Diagram

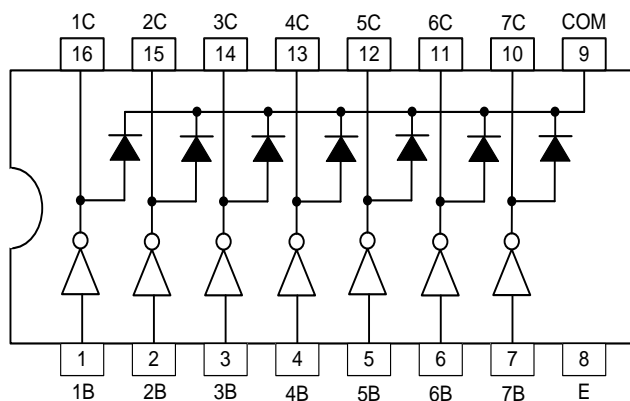

Pin Descriptions

Pin Number	Pin Name	Function
1	1B	Input Pair 1
2	2B	Input Pair 2
3	3B	Input Pair 3
4	4B	Input Pair 4
5	5B	Input Pair 5
6	6B	Input Pair 6
7	7B	Input Pair 7
8	E	Common Emitter (ground)
9	COM	Common Clamp Diodes
10	7C	Output Pair 7
11	6C	Output Pair 6
12	5C	Output Pair 5
13	4C	Output Pair 4
14	3C	Output Pair 3
15	2C	Output Pair 2
16	1C	Output Pair 1

Functional Block Diagram

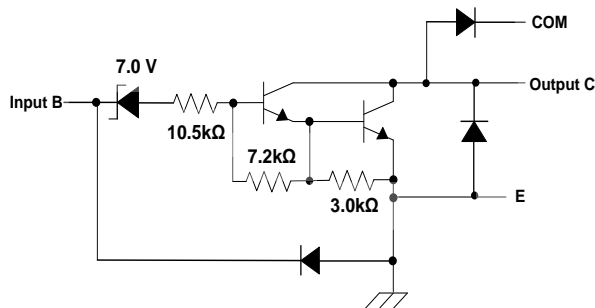

ULN2002A

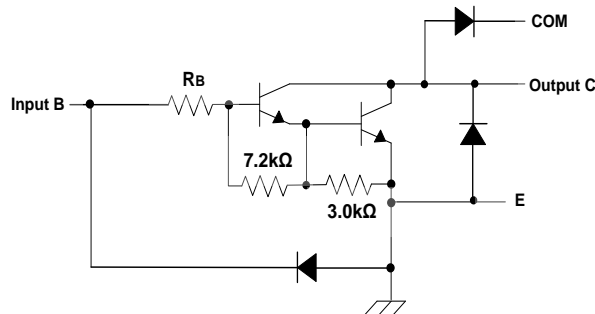

ULN2003A: $R_B = 2k7$
 ULN2004A: $R_B = 10k5$
ULN2003A, ULN2004A



ULN2002A/ ULN2003A/ ULN2004A

Absolute Maximum Ratings (Note 4) (@T_A = +25°C, unless otherwise specified.)

Symbol	Parameter	Rating	Unit	
V _{CC}	Collector to Emitter Voltage	50	V	
V _R	Clamp Diode Reverse Voltage (Note 5)	50	V	
V _I	Input Voltage (Note 5)	30	V	
I _{CP}	Peak Collector Current	See typical characteristics	mA	
I _{OK}	Output Clamp Current	500	mA	
I _{TE}	Total Emitter Current	-2.5	A	
θ _{JA}	Thermal Resistance Junction-to-Ambient (Note 6)	SO-16	63.0	°C/W
		DIP-16	50.0	
θ _{JC}	Thermal Resistance Junction-to-Case (Note 6)	SO-16	12.0	°C/W
		DIP-16	15.0	
T _J	Junction Temperature	150	°C	
T _{STG}	Storage Temperature	-65 to +150	°C	

- Notes:
- Stresses beyond those listed under "absolute maximum ratings" may cause permanent damage to the device. These are stress ratings only. Functional operation of the device at these or any other conditions beyond those indicated under "recommended operating conditions" is not implied. Exposure to absolute-maximum-rated conditions for extended periods may affect device reliability.
 - All voltage values are with respect to the emitter/substrate terminal E, unless otherwise noted.
 - Maximum power dissipation is a function of T_{J(max)}, θ_{JA}, and T_A. The maximum allowable power dissipation at any allowable ambient temperature is P_D = (T_{J(max)} - T_A)/θ_{JA}. Operating at the absolute maximum T_J of 150°C can affect reliability.
 - Maximum power dissipation is a function of T_{J(max)}, θ_{JC}, and T_A. The maximum allowable power dissipation at any allowable ambient temperature is P_D = (T_{J(max)} - T_C)/θ_{JA}. Operating at the absolute maximum T_J of 150°C can affect reliability.

Recommended Operating Conditions

Symbol	Parameter	Min	Max	Unit
V _{CC}	Collector to Emitter voltage	-	50	V
T _A	Operating Ambient Temperature	-40	+105	°C

Electrical Characteristics (@T_A = +25°C, unless otherwise specified.)

ULN2002A								
Parameter	Test Figure	Test Conditions	Min	Typ	Max	Unit		
V _{I(on)}	On State Input Voltage	6	V _{CE} = 2V, I _C = 300mA	-	-	13	V	
V _{CE(sat)}	Collector Emitter Saturation Voltage	5	I _I = 250μA, I _C = 100mA	-	0.9	1.1	V	
			I _I = 350μA, I _C = 200mA	-	1	1.3		
			I _I = 500μA, I _C = 350mA	-	1.2	1.6		
V _F	Clamp Forward Voltage	8	I _F = 350mA	-	1.7	2	V	
I _{CEX}	Collector Cut-off Current	1	V _{CE} = 50V, I _I = 0	-	-	50	μA	
			V _{CE} = 50V, T _A = +105°C	I _I = 0	-	-		100
		2	V _I = 6V	-	-	500		
I _{I(off)}	Off State Input Current	3	V _{CE} = 50V, I _C = 500μA	50	65	-	μA	
I _I	Input Current	4	V _I = 17V	-	0.82	1.25	mA	
I _R	Clamp Reverse Current	7	V _R = 50V	T _A = +105°C	-	-	100	μA
			-	-	-	-	50	
C _I	Input Capacitance	-	V _I = 0, f = 1MHz	-	-	25	pF	



ULN2002A/ ULN2003A/ ULN2004A

Electrical Characteristics (@T_A = +25°C, unless otherwise specified.)

ULN2003A									
Parameter	Test Figure	Test Conditions		Min	Typ	Max	Unit		
V _{I(on)}	On State Input Voltage	6	V _{CE} = 2V	I _C = 200mA	-	-	2.4	V	
				I _C = 250mA	-	-	2.7		
				I _C = 300mA	-	-	3		
V _{CE(sat)}	Collector Emitter Saturation Voltage	5		I _I = 250μA, I _C = 100mA	-	0.9	1.1	V	
				I _I = 350μA, I _C = 200mA	-	1	1.3		
				I _I = 500μA, I _C = 350mA	-	1.2	1.6		
V _F	Clamp Forward Voltage	8		I _F = 350mA	-	1.7	2	V	
I _{CEX}	Collector Cut-off Current	1		V _{CE} = 50V, I _I = 0	-	-	50	μA	
		2		V _{CE} = 50V, T _A = +105°C, I _I = 0	-	-	100		
I _{I(off)}	Off State Input Current	3		V _{CE} = 50V, I _C = 500μA	50	65	-	μA	
I _I	Input Current	4		V _I = 3.85V	-	0.93	1.35	mA	
I _R	Clamp Reverse Current	7		V _R = 50V	T _A = +105°C	-	-	100	μA
					-	-	-	50	
C _I	Input Capacitance	-		V _I = 0, f = 1MHz	-	15	25	pF	
ULN2004A									
Parameter	Test Figure	Test Conditions		Min	Typ	Max	Unit		
V _{I(on)}	On State Input Voltage	6	V _{CE} = 2V	I _C = 125mA	-	-	5	V	
				I _C = 200mA	-	-	6		
				I _C = 275mA	-	-	7		
				I _C = 350mA	-	-	8		
V _{CE(sat)}	Collector Emitter Saturation Voltage	5		I _I = 250μA, I _C = 100mA	-	0.9	1.1	V	
				I _I = 350μA, I _C = 200mA	-	1	1.3		
				I _I = 500μA, I _C = 350mA	-	1.2	1.6		
V _F	Clamp Forward Voltage	8		I _F = 350mA	-	1.7	2	V	
I _{CEX}	Collector Cut-off Current	1		V _{CE} = 50V, I _I = 0	-	-	50	μA	
		2		V _{CE} = 50V, T _A = +105°C, I _I = 0, V _I = 6V	-	-	500		
I _{I(off)}	Off State Input Current	3		V _{CE} = 50V, I _C = 500μA	50	65	-	μA	
I _I	Input Current	4		V _I = 5V	-	0.35	0.5	mA	
I _R	Clamp Reverse Current	7		V _R = 50V	T _A = +105°C	-	-	100	μA
					-	-	-	50	
C _I	Input Capacitance	-		V _I = 0, f = 1MHz	-	15	25	pF	



ULN2002A/ ULN2003A/ ULN2004A

Electrical Characteristics (@T_A = -40°C to +105°C, unless otherwise specified.)

ULN2003A								
Parameter		Test Figure	Test Conditions	Min	Typ	Max	Unit	
V _{I(on)}	On State Input Voltage	6	V _{CE} = 2V	I _C = 200mA	-	-	2.7	V
				I _C = 250mA	-	-	2.9	
				I _C = 300mA	-	-	3	
V _{CE(sat)}	Collector Emitter Saturation Voltage	5	I _I = 250μA, I _C = 100mA	-	0.9	1.2	V	
			I _I = 350μA, I _C = 200mA	-	1	1.4		
			I _I = 500μA, I _C = 350mA	-	1.2	1.7		
V _F	Clamp Forward Voltage	8	I _F = 350mA	-	1.7	2.2	V	
I _{CEX}	Collector Cut-off Current	1	V _{CE} = 50V, I _I = 0	-	-	100	μA	
I _{I(off)}	Off State Input Current	3	V _{CE} = 50V, I _C = 500μA	30	65	-	μA	
I _I	Input Current	4	V _I = 3.85V	-	0.93	1.35	mA	
I _R	Clamp Reverse Current	7	V _R = 50V	-	-	100	μA	
C _I	Input Capacitance	-	V _I = 0, f = 1MHz	-	15	25	pF	

Switching Characteristics (@T_A = +25°C, unless otherwise specified.)

ULN2002A, ULN2003A, ULN2004A						
Parameter		Test figure	Min	Typ	Max	Unit
t _{PLH}	Propagation delay time, low to high level output	10	-	0.25	1	μs
t _{PLL}	Propagation delay time, high to low level output	10	-	0.25	1	μs
V _{OH}	High level output voltage after switching	10 (V _S = 50V, I _O = 300mA)	V _S -20	-	-	mV

Switching Characteristics (@T_A = -40 to +105°C, unless otherwise specified.)

ULN2003A						
Parameter		Test figure	Min	Typ	Max	Unit
t _{PLH}	Propagation delay time, low to high level output	10	-	1	10	μs
t _{PLL}	Propagation delay time, high to low level output	10	-	1	10	μs
V _{OH}	High level output voltage after switching	10 (V _S = 50V, I _O = 300mA)	V _S -50	-	-	mV

Parameter Measurement Circuits

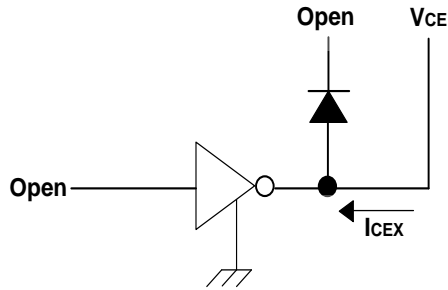

Fig.1 ICEX Test Circuit

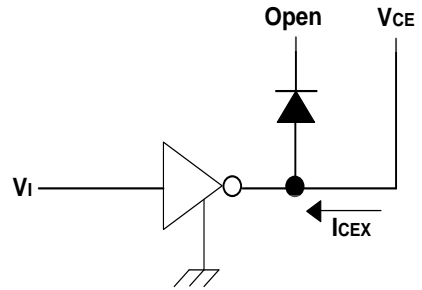

Fig.2 ICEX Test Circuit

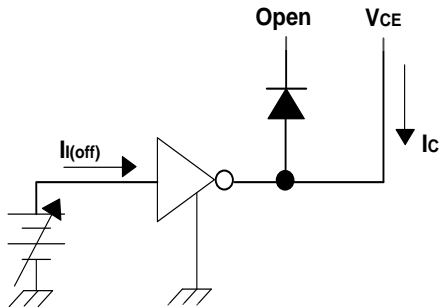

Fig.3 I(off) Test Circuit

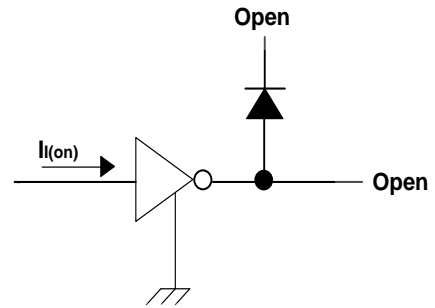

Fig.4 I(on) Test Circuit

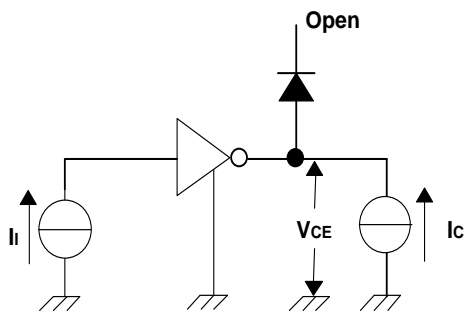

Fig. 5 hFE , VCE(sat) Test Circuit

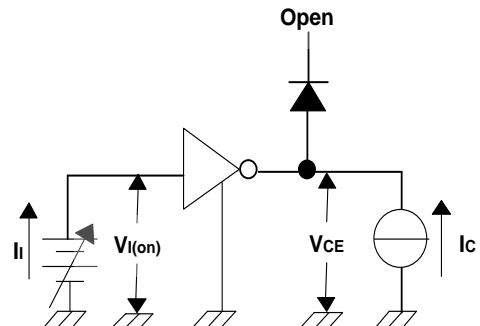

Fig. 6 VI(on) Test Circuit

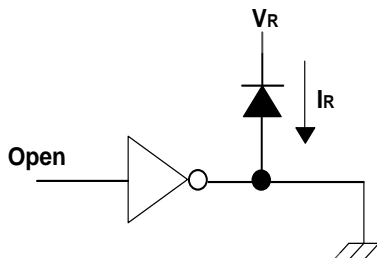

Fig. 7 IR Test Circuit

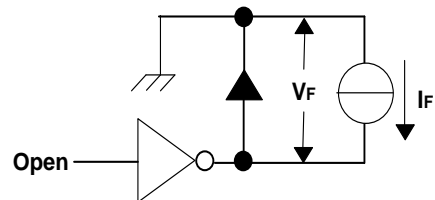

Fig. 8 VF Test Circuit

Parameter Measurement Circuits (continued)

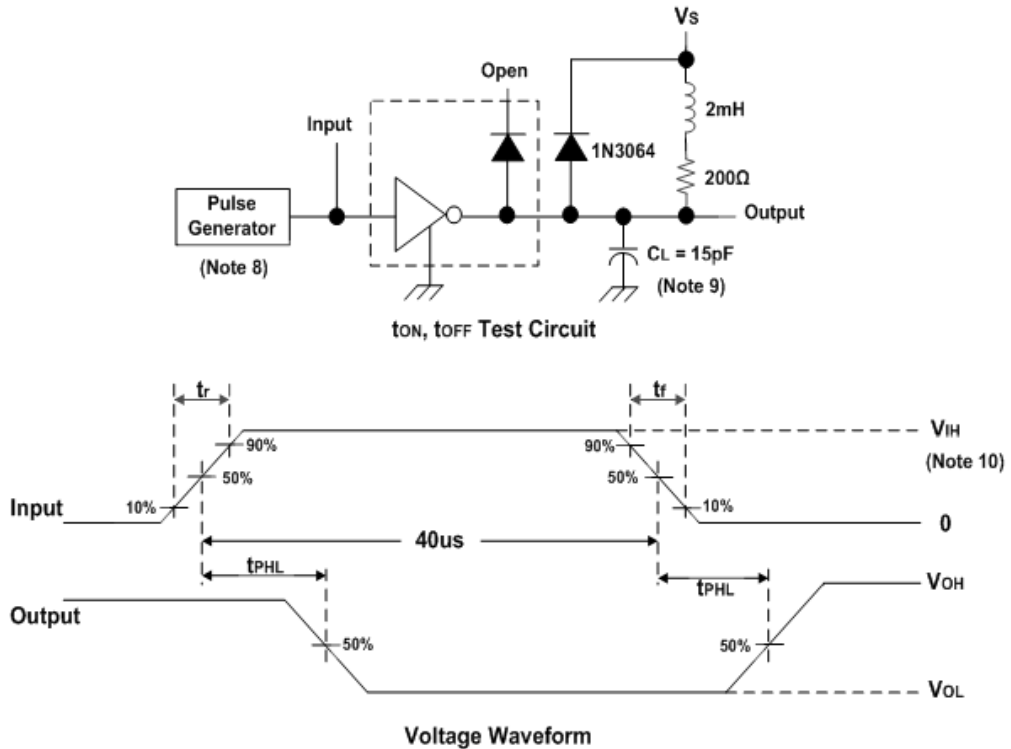

Fig. 10 Latch-Up Test Circuit and Voltage Waveform

- Notes:
- 8. The pulse generator has the following characteristics: Pulse Width = 12.5Hz, output impedance 50Ω, $t_r \leq 5\text{ns}$, $t_f \leq 10\text{ns}$.
 - 9. C_L includes probe and jig capacitance.
 - 10. For testing the ULN2002A, $V_{IH} = 13\text{V}$; for the ULN2003A, $V_{IH} = 3\text{V}$; for the ULN2004A, $V_{IH} = 8\text{V}$.

Typical Performance Characteristics

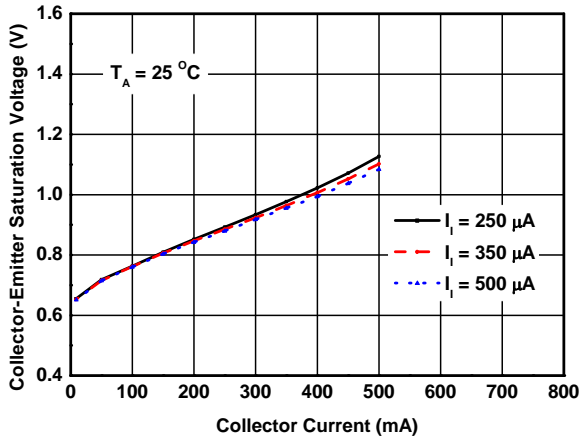

Figure 11 Collector-Emitter Saturation Voltage vs. Collector Current (One Darlington)

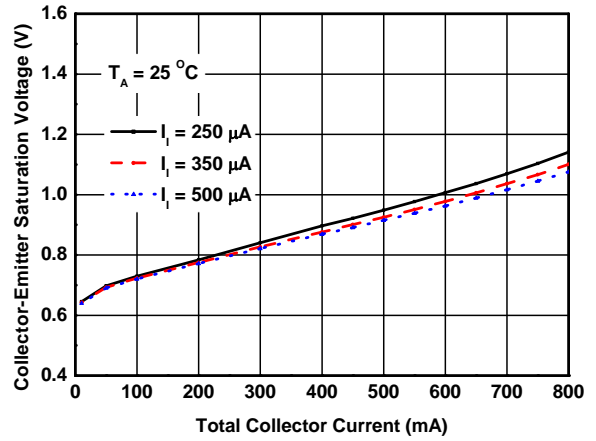

Figure 12 Collector-Emitter Saturation Voltage vs. Collector Current (Two Darlington in Parallel)

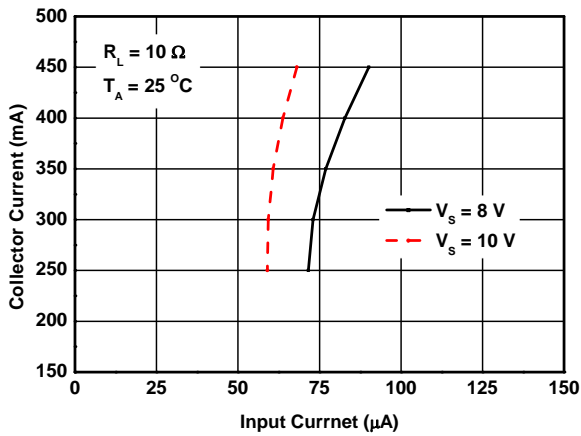

Figure 13 Collector Current vs. Input Current

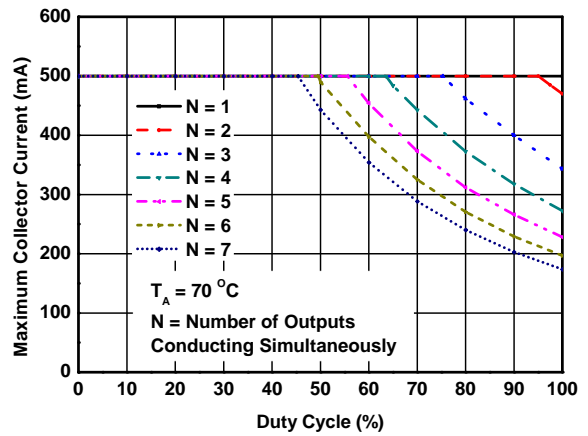

Figure 14 Maximum Collector Current vs. Duty Cycle

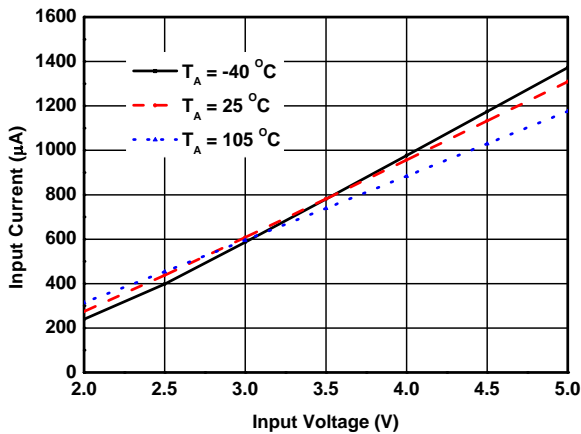

Figure 15. Input Current vs. Input Voltage

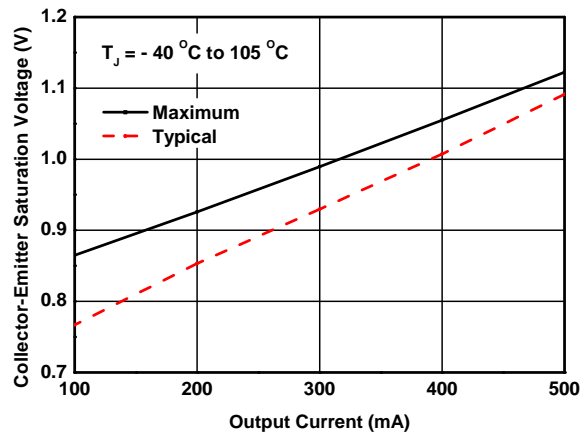

Figure 16. Collector-Emitter Saturation Voltage vs. Output Current

Typical Performance Characteristics (continued)

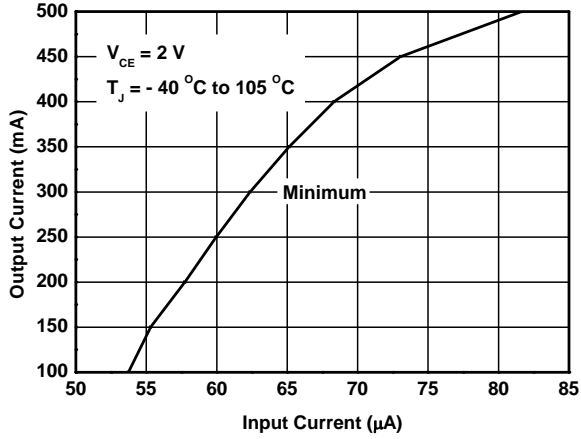
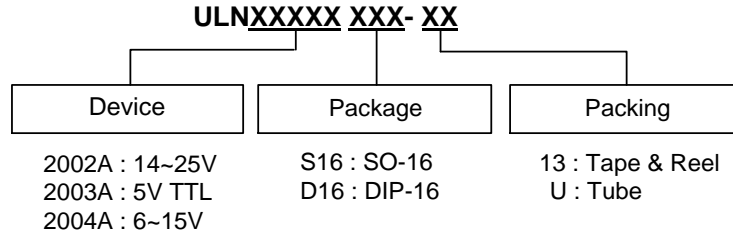

Figure 17. Output Current vs. Input Current



ULN2002A/ ULN2003A/ ULN2004A

Ordering Information



Part Number	Package Code	Packaging	13" Tape and Reel		Tube	
			Quantity	Part Number Suffix	Quantity	Part Number Suffix
ULN2002AS16-13	S16	SO-16	2,500/Tape & Reel	-13	NA	NA
ULN2003AS16-13	S16	SO-16	2,500/Tape & Reel	-13	NA	NA
ULN2004AS16-13	S16	SO-16	2,500/Tape & Reel	-13	NA	NA
ULN2002AD16-U	D16	PDIP-16	NA	NA	25/Tube	-U
ULN2003AD16-U	D16	PDIP-16	NA	NA	25/Tube	-U
ULN2004AD16-U	D16	PDIP-16	NA	NA	25/Tube	-U

Note: 11. Pad layout as shown on Diodes Inc. suggested pad layout document AP02001, which can be found on our website at <http://www.diodes.com/datasheets/ap02001.pdf>.

Marking Information

(1) SO-16

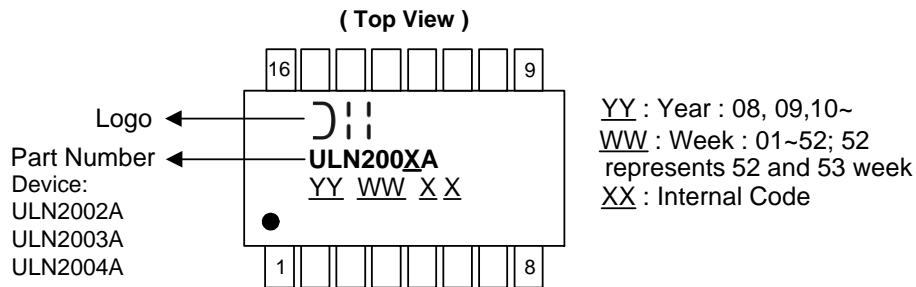

(2) PDIP-16

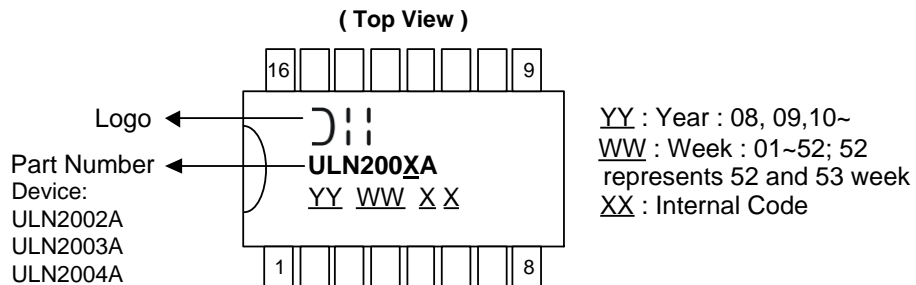

Package Outline Drawings

Please see AP02002 at <http://www.diodes.com/datasheets/ap02002.pdf> for the latest version.

SO-16

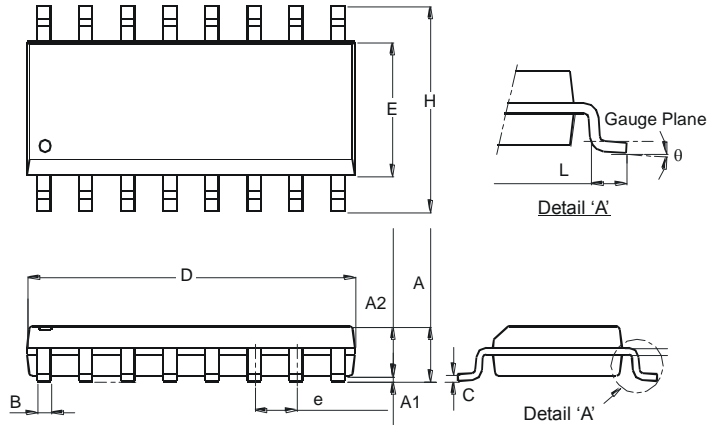

SO-16		
Dim	Min	Max
A	1.40	1.75
A1	0.10	0.25
A2	1.30	1.50
B	0.33	0.51
C	0.19	0.25
D	9.80	10.00
E	3.80	4.00
e	1.27 Typ	
H	5.80	6.20
L	0.38	1.27
θ	0°	8°
All Dimensions in mm		

PDIP-16

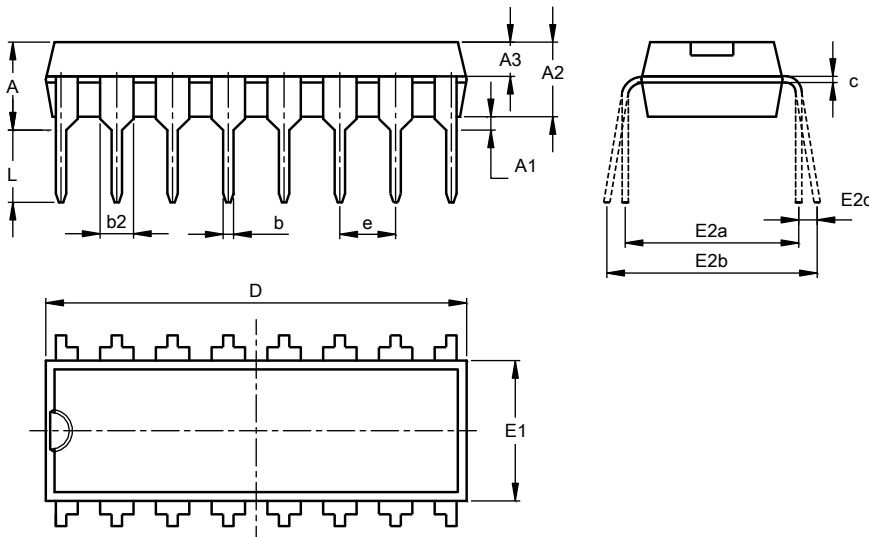

PDIP-16			
Dim	Min	Max	Nom
A	3.60	4.00	3.80
A1	0.51	-	-
A2	3.20	3.40	3.30
A3	1.47	1.57	1.52
b	0.44	0.53	-
b2	1.52BSC		
c	0.25	0.31	-
D	18.90	19.30	19.10
E1	6.15	6.55	6.35
E2a	7.62 BSC		
E2b	7.62	9.30	-
E2c	0.00	0.84	-
e	2.54BSC		
L	3.00	-	-
All Dimensions in mm			



ULN2002A/ ULN2003A/ ULN2004A

Suggested Pad Layout

Please see AP02001 at <http://www.diodes.com/datasheets/ap02001.pdf> for the latest version.

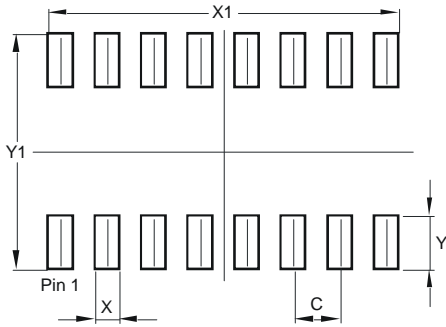

Dimensions	Value (in mm)
C	1.270
X	0.670
X1	9.560
Y	1.450
Y1	6.400

**ULN2002A/ ULN2003A/ ULN2004A****IMPORTANT NOTICE**

DIODES INCORPORATED MAKES NO WARRANTY OF ANY KIND, EXPRESS OR IMPLIED, WITH REGARDS TO THIS DOCUMENT, INCLUDING, BUT NOT LIMITED TO, THE IMPLIED WARRANTIES OF MERCHANTABILITY AND FITNESS FOR A PARTICULAR PURPOSE (AND THEIR EQUIVALENTS UNDER THE LAWS OF ANY JURISDICTION).

Diodes Incorporated and its subsidiaries reserve the right to make modifications, enhancements, improvements, corrections or other changes without further notice to this document and any product described herein. Diodes Incorporated does not assume any liability arising out of the application or use of this document or any product described herein; neither does Diodes Incorporated convey any license under its patent or trademark rights, nor the rights of others. Any Customer or user of this document or products described herein in such applications shall assume all risks of such use and will agree to hold Diodes Incorporated and all the companies whose products are represented on Diodes Incorporated website, harmless against all damages.

Diodes Incorporated does not warrant or accept any liability whatsoever in respect of any products purchased through unauthorized sales channel.

Should Customers purchase or use Diodes Incorporated products for any unintended or unauthorized application, Customers shall indemnify and hold Diodes Incorporated and its representatives harmless against all claims, damages, expenses, and attorney fees arising out of, directly or indirectly, any claim of personal injury or death associated with such unintended or unauthorized application.

Products described herein may be covered by one or more United States, international or foreign patents pending. Product names and markings noted herein may also be covered by one or more United States, international or foreign trademarks.

This document is written in English but may be translated into multiple languages for reference. Only the English version of this document is the final and determinative format released by Diodes Incorporated.

LIFE SUPPORT

Diodes Incorporated products are specifically not authorized for use as critical components in life support devices or systems without the express written approval of the Chief Executive Officer of Diodes Incorporated. As used herein:

A. Life support devices or systems are devices or systems which:

1. are intended to implant into the body, or
2. support or sustain life and whose failure to perform when properly used in accordance with instructions for use provided in the labeling can be reasonably expected to result in significant injury to the user.

B. A critical component is any component in a life support device or system whose failure to perform can be reasonably expected to cause the failure of the life support device or to affect its safety or effectiveness.

Customers represent that they have all necessary expertise in the safety and regulatory ramifications of their life support devices or systems, and acknowledge and agree that they are solely responsible for all legal, regulatory and safety-related requirements concerning their products and any use of Diodes Incorporated products in such safety-critical, life support devices or systems, notwithstanding any devices- or systems-related information or support that may be provided by Diodes Incorporated. Further, Customers must fully indemnify Diodes Incorporated and its representatives against any damages arising out of the use of Diodes Incorporated products in such safety-critical, life support devices or systems.

Copyright © 2015, Diodes Incorporated

www.diodes.com