

Excellent Integrated System Limited

Stocking Distributor

Click to view price, real time Inventory, Delivery & Lifecycle Information:

[Lumex, Inc.](#)
[GT-CM600L](#)

For any questions, you can email us directly:

sales@integrated-circuit.com

UNCONTROLLED DOCUMENT

PART NUMBER GT-CM600L	REV.
--------------------------	------

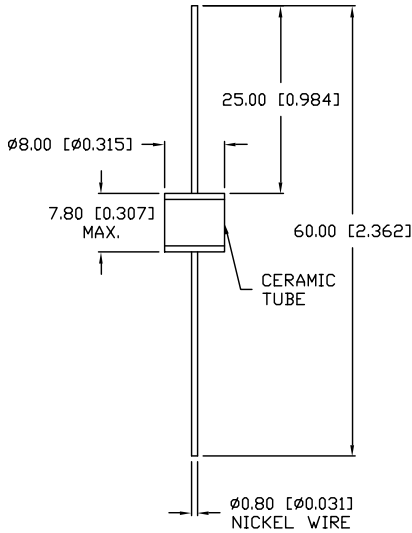

ELECTRICAL SPECIFICATIONS		
PARAMETER	VALUE	TEST CONDITION
D.C. FIRING VOLTAGE:	600V±15% D.C.	(dv/dt 100V/S)
IMPULSE FIRING VOLTAGE:	900V D.C. MAX.	(dv/dt 100V/μS)
IMPULSE CURRENT:	10KA MAX.	(8/20μS)
D.C. HOLDOVER VOLTAGE:	200V D.C. MAX.	(150mS MAX.)
A.C. DISCHARGE CURRENT:	10A	(1S X 10 TIMES)
INSULATION RESISTANCE:	10 ³ MΩ MIN.	(50 OR 100VDC)
INTER-ELECTRODE CAPACITANCE:	0.5 PF MAX.	1.0kHz

ENVIRONMENTAL SPECIFICATIONS PER MIL-STD 202			
TEST	METHODE	CONDITION	RATING
VIBRATION TESTING:	204B	C	10-55Hz, .06DA
SHOCK	213A	C	100 g
HUMIDITY:	103B	B	95% Re. HUMIDITY
TEMPERATURE CYCLING:	102A	C	- 65 TO + 125 °C
BAROMETRIC PRESSURE:	105C	B	50,000 ft.
THERMAL SHOCK:	107	B	- 65 TO + 125 °C
SOLDERABILITY:	208	B	

RESPONSE TIME	
SURGE TYPE	(Rt MAX.)
1Kv/mS	1 x 10 ⁻⁹ sec.
1Kv/μS	1 x 10 ⁻⁸ sec.
5Kv/μS	1 x 10 ⁻⁹ sec.

UNCONTROLLED DOCUMENT

*TOLERANCES PER DECIMAL PRECISION ARE: X=±1 (±0.039), X.X=±0.5 (±0.020), X.XX=±0.25 (±0.010), X.XXX=±0.127 (±0.005). LEAD LENGTH=±0.75 (±0.030), MIN=-0.00, MAX.=+0.00

REV.	PART NUMBER GT-CM600L	<p>CONFIDENTIAL INFORMATION</p> <p>THE INFORMATION CONTAINED IN THIS DOCUMENT IS THE PROPERTY OF LUMEX INC. EXCEPT AS SPECIFICALLY AUTHORIZED IN WRITING BY LUMEX INC. THE HOLDER OF THIS DOCUMENT SHALL KEEP ALL INFORMATION CONTAINED HEREIN CONFIDENTIAL AND SHALL PROTECT SAME IN WHOLE OR IN PART FROM DISCLOSURE AND DISSEMINATION TO ALL THRD PARTIES.</p>	<p>290 E. HELLEN ROAD PALATINE, ILLINOIS 60067 PHONE: (847) 359-2790 WEB: http://www.lumex.com</p>												
HEAVY DUTY CERAMIC SURGE PROTECTOR, 2 LEADED		<p>RELIABILITY NOTE</p> <p>OUR MANY YEARS OF EXPERIENCE DATA ACCUMULATION INDICATE THAT SOLDER HEAT IS A MAJOR CAUSE OF EARLY AND FUTURE FAILURE. PLEASE PAY ATTENTION TO YOUR SOLDERING PROCESS.</p>	<table border="1"> <tr> <td>DRAWN BY: KS/SK</td> <td>CHECKED BY:</td> <td>APPROVED BY:</td> <td>DATE: 3-27-00</td> </tr> <tr> <td></td> <td></td> <td></td> <td>PAGE: 1 OF 1</td> </tr> <tr> <td></td> <td></td> <td></td> <td>SCALE: N/A</td> </tr> </table>	DRAWN BY: KS/SK	CHECKED BY:	APPROVED BY:	DATE: 3-27-00				PAGE: 1 OF 1				SCALE: N/A
DRAWN BY: KS/SK	CHECKED BY:	APPROVED BY:	DATE: 3-27-00												
			PAGE: 1 OF 1												
			SCALE: N/A												