

Excellent Integrated System Limited

Stocking Distributor

Click to view price, real time Inventory, Delivery & Lifecycle Information:

[Analog Devices Inc.](#)
[HMC-C088](#)

For any questions, you can email us directly:

sales@integrated-circuit.com



Analog Devices Welcomes Hittite Microwave Corporation

NO CONTENT ON THE ATTACHED DOCUMENT HAS CHANGED

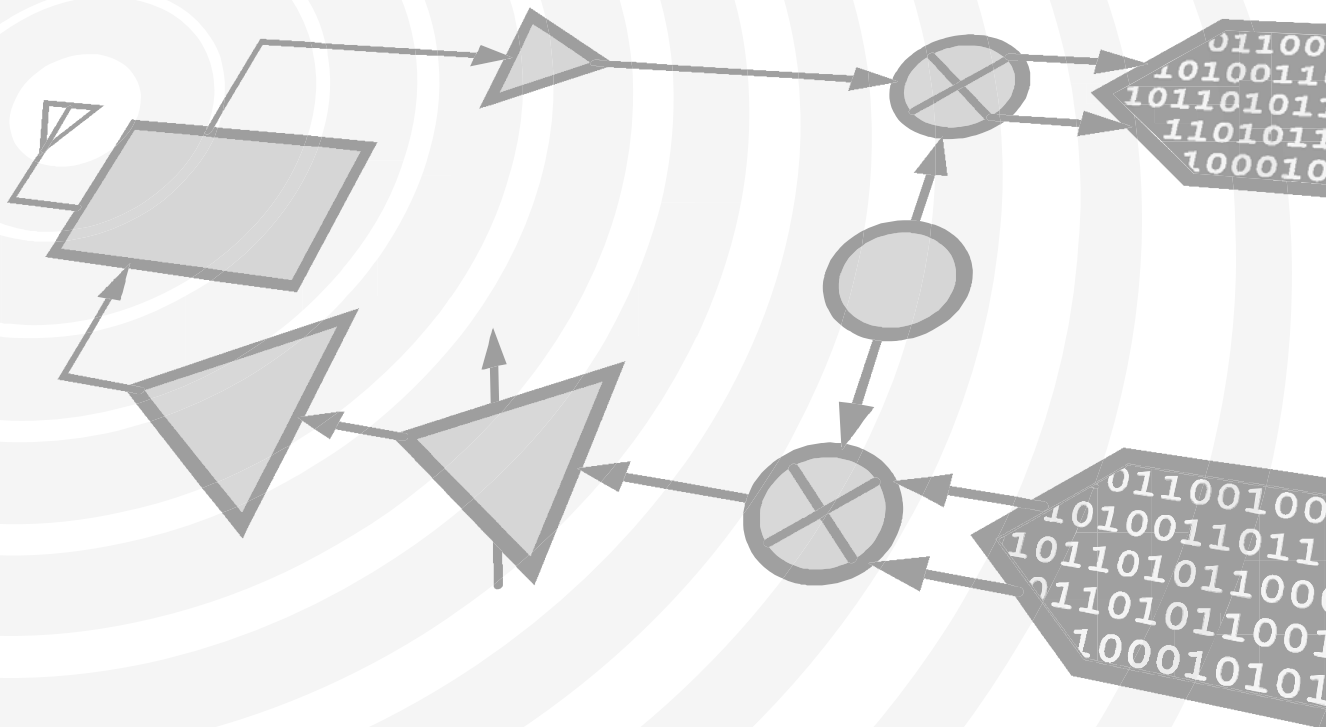

THIS PAGE INTENTIONALLY LEFT BLANK



HMC-C088

SUCCESSIVE DETECTION LOG VIDEO AMPLIFIER (SDLVA) 1 - 20 GHz

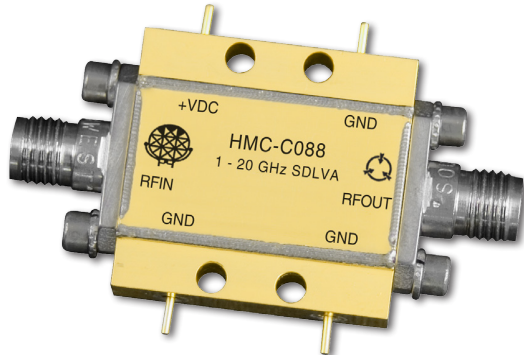

Features

- 1 to 20 GHz Operation
- High Logging Range: 59 dB
- Output Frequency Flatness: ± 2 dB
- Internal Voltage Regulation
- Fast Rise/Fall Times: 2/7 ns
- Hermetically Sealed Module
- Single Positive Supply: +7V to +16V
- 55 °C to +85 °C Operating Temperature

Typical Applications

- The HMC-C088 is ideal for:
- EW, ELINT & IFM Receivers
 - DF Radar Systems
 - ECM Systems
 - Broadband Test & Measurement
 - Power Measurement & Control Circuits
 - Military & Space Applications

General Description

The HMC-C088 is a Successive Detection Log Video Amplifier (SDLVA) which operates from 1 to 20 GHz. The HMC-C088 provides a logging range of 59 dB.

This product comes standard with two female SMA field replaceable connectors but can also be used with blind mate SMP connectors or as a drop-in module. The package size measures 1.086 x 0.85 x 0.23" (27.58 x 21.6 x 5.84 mm) making it ideal for environmentally robust applications where space is limited.

The HMC-C088 has an integrated voltage regulator that allows the SDLVA to operate from a single supply between +7 and +16V without any appreciable change in performance.

Functional Diagram

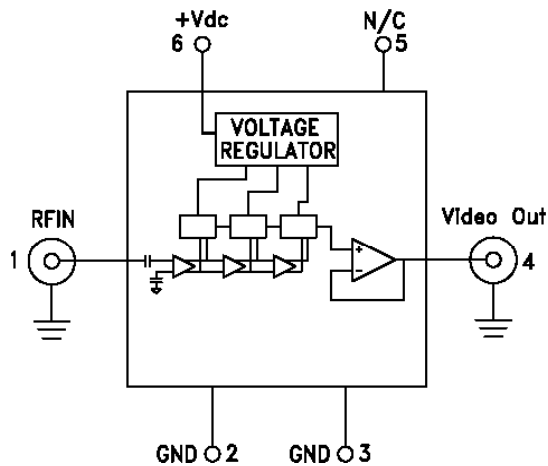

Electrical Specifications, $T_A = +25^\circ\text{C}$ $V_{dc} = +12\text{V}$

Parameter	Conditions	Typ.	Units
Input Frequency Range		1 - 20	GHz
Frequency Flatness	Pin= -30 dBm	± 2	dB
Log Linearity	Pin= -50 dBm to +0 dBm	± 1	dBm
Log Linearity over Temperature	-55 to +85° C, Pin= -30 dBm	± 1	dB
Minimum Logging Range	to ± 3 dB error	-54	dBm
Maximum Logging Range	to ± 3 dB error	+5	dBm
Input Return Loss		9	dB
Log Video Minimum Output Voltage		0.9	V

For price, delivery and to place orders: Hittite Microwave Corporation, 2 Elizabeth Drive, Chelmsford, MA 01824
 978-250-3343 tel • 978-250-3373 fax • Order On-line at www.hittite.com
 Application Support: Phone: 978-250-3343 or apps@hittite.com



HMC-C088

SUCCESSIVE DETECTION LOG VIDEO AMPLIFIER (SDLVA) 1 - 20 GHz

Electrical Specifications, (continued)

Parameter	Conditions	Typ.	Units
Log Video Maximum Output Voltage		1.5	V
Log Video Output Rise Time	Pin = -20 dBm, 10% to 90%	2	ns
Log Video Output Fall Time	Pin = -20 dBm, 90% to 10%	7	ns
Vdc Voltage Range	7 - 16	12	V
Log Video Recovery Time	-50 dBm to 0 dBm	21	ns
Log Video Output Slope		14	mV/dB
Log Video Output Slope Variation over Temperature	@ 10 GHz	5	μV/dB°C
Log Video Propagation Delay		3	ns
Supply Current (I _{dc})		86	mA

Error Flatness vs. Input Power Over Frequency

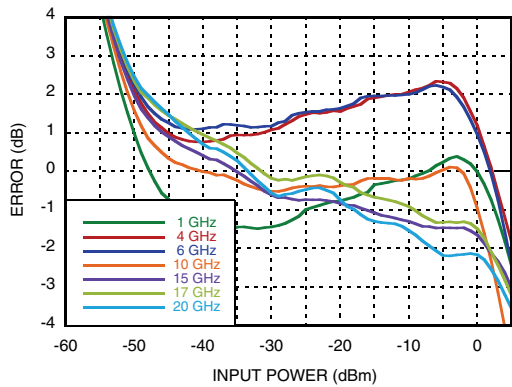

X-Band Error Flatness vs. Input Power Over Frequency

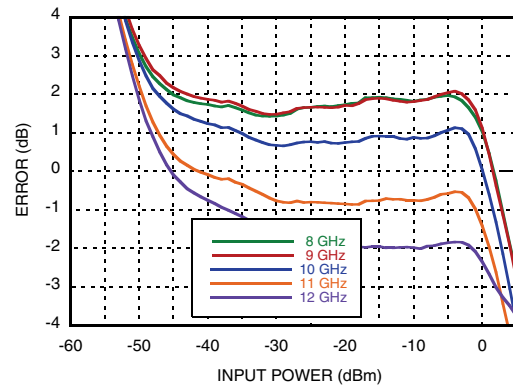

VIDEO OUT & Error vs. Input Power, Fin= 1 GHz

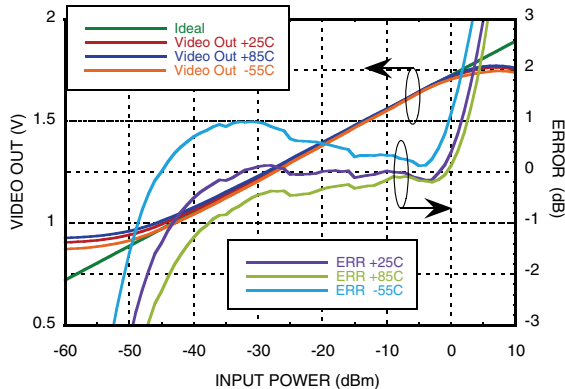

VIDEO OUT & Error vs. Input Power, Fin= 4 GHz

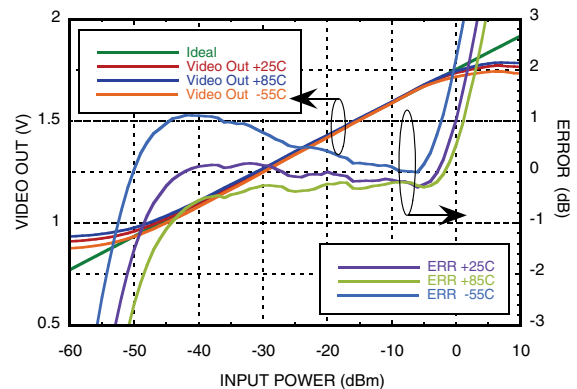

**SUCCESSIVE DETECTION LOG VIDEO AMPLIFIER (SDLVA)
 1 - 20 GHz**

VIDEO OUT & Error vs. Input Power, f_{in} = 6 GHz

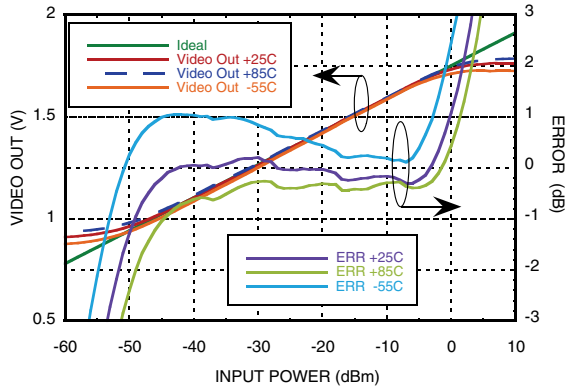

VIDEO OUT & Error vs. Input Power, f_{in} = 10 GHz

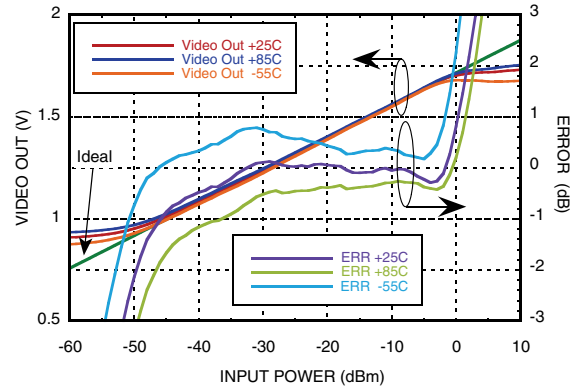

VIDEO OUT vs. Error vs. Input Power, f_{in} = 12 GHz

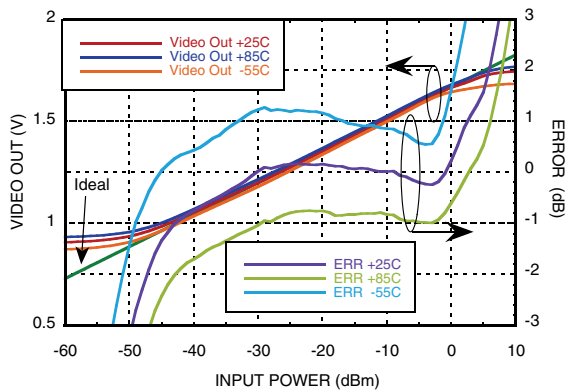

VIDEO OUT & Error vs. Input Power, f_{in} = 15 GHz

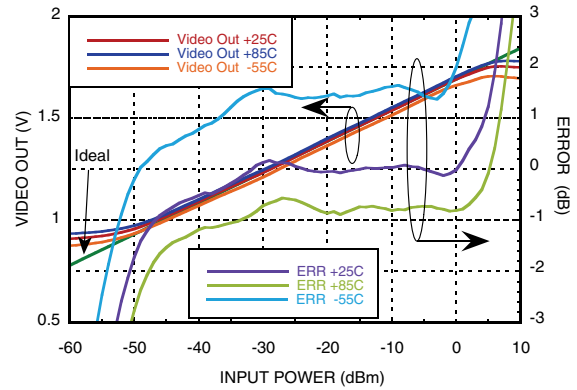

VIDEO OUT & Error vs. Input Power, f_{in} = 17 GHz

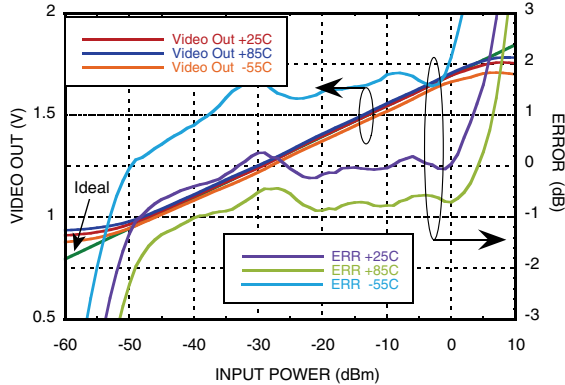

VIDEO OUT & Error vs. Input Power, f_{in} = 20 GHz

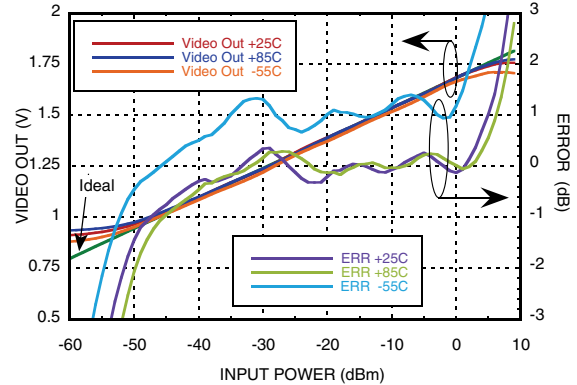

**SUCCESSIVE DETECTION LOG VIDEO AMPLIFIER (SDLVA)
 1 - 20 GHz**

**VIDEO OUT vs. Frequency
 Over Input Power & Temperature**

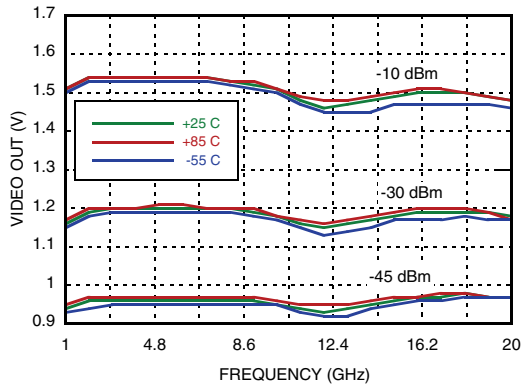

Input Return Loss vs. Frequency

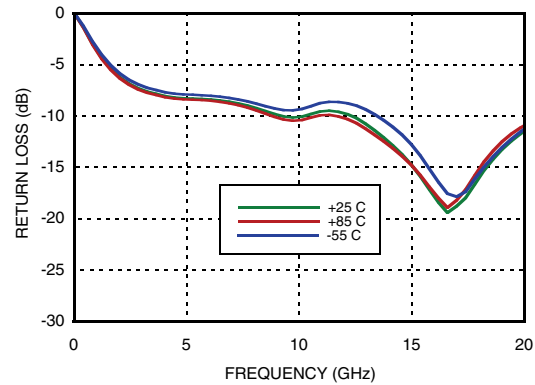

Rise Time @ 10 GHz @ -20 dBm

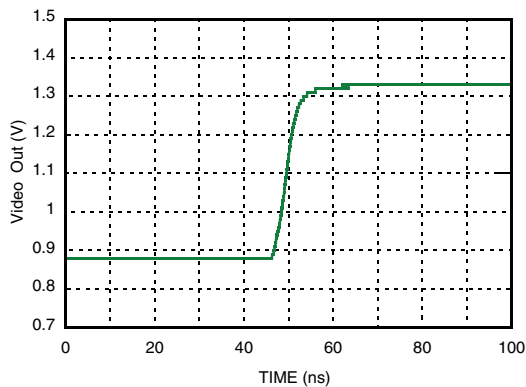

Fall Time @ 10 GHz @ -20 dBm

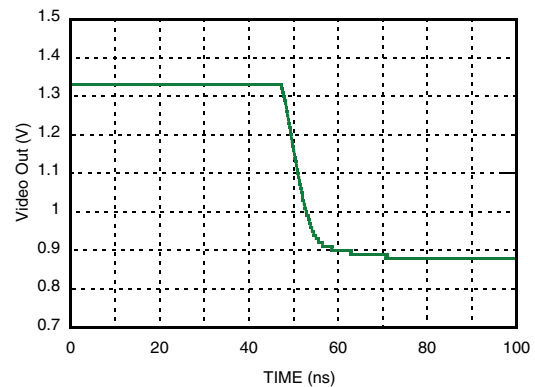

Absolute Maximum Ratings

Icc	100 mA
Input Signal Amplitude	18 dBm
Junction Temperature	125 °C
Continuous Pdiss (T=85°C) Derate 59 mW/°C above 85°C	1.6 W
Thermal Resistance (R _{th}) (junction to package bottom)	17 °C/W
Vdc Max	+16V
Storage Temperature	-65 to +150 °C
Operating Temperature	-55 to +85 °C
ESD Sensitivity (HBM)	Class 1A



**ELECTROSTATIC SENSITIVE DEVICE
 OBSERVE HANDLING PRECAUTIONS**



HMC-C088

SUCCESSIVE DETECTION LOG VIDEO AMPLIFIER (SDLVA) 1 - 20 GHz

Outline Drawing

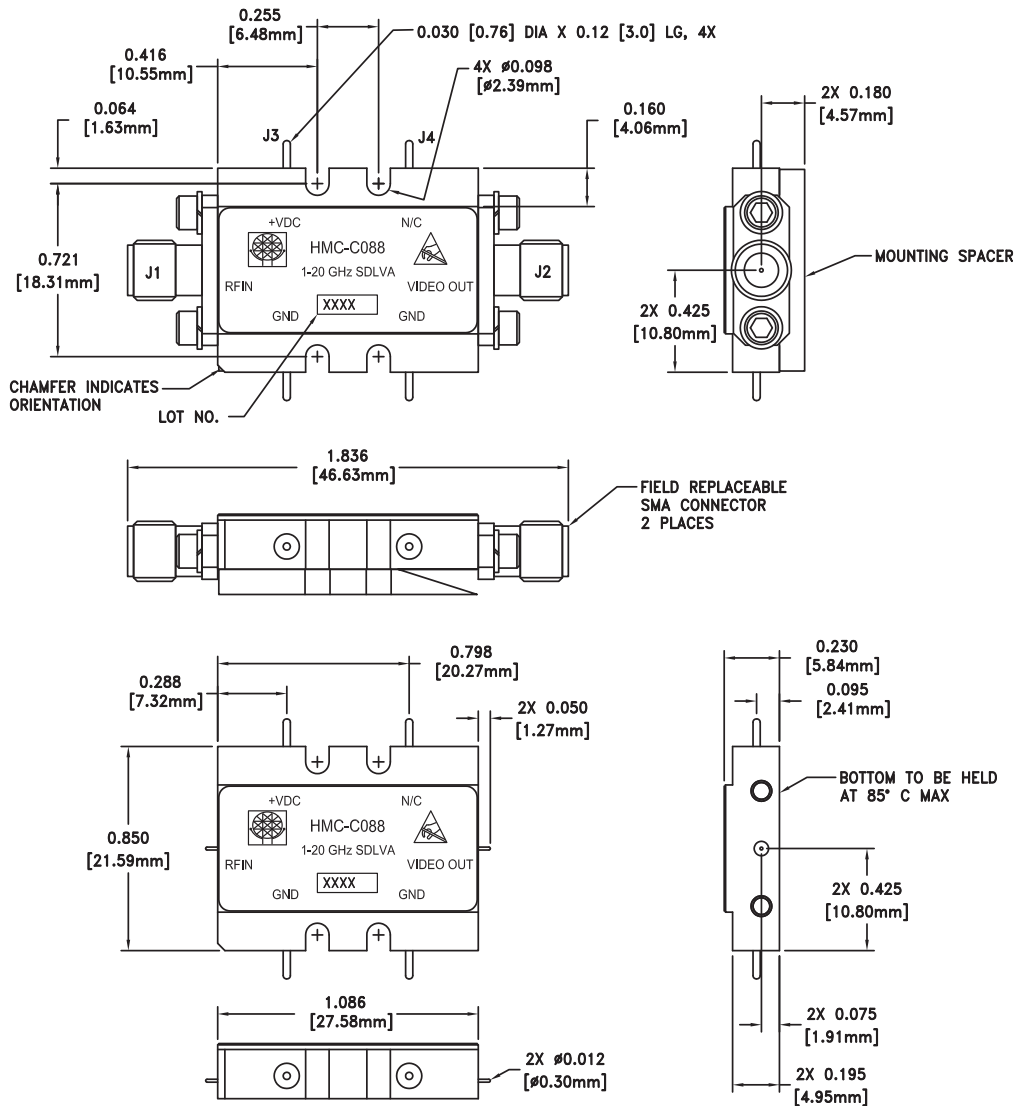

Package Information

Package Type	C-10
Package Weight [1]	16.7 gms [2]
Spacer Weight	3.3 gms [2]

[1] Includes the connectors

[2] ±1 gms Tolerance

NOTES:

- NOTES:
1. PACKAGE, LEADS, COVER MATERIAL: KOVAR™
 2. PLATING: GOLD PLATE OVER NICKEL PLATE.
 3. MOUNTING SPACER: NICKEL PLATED ALUMINUM.
 4. ALL DIMENSIONS ARE IN INCHES [MILLIMETERS].
 5. TOLERANCES:
 - 5.1 .XX = ±.02
 - 5.2 .XXX = ±.010
 6. MARK LOT NUMBER ON 0.080 X 0.250 LABEL WHERE SHOWN WITH .030" MIN TEXT HEIGHT.
 7. MOUNTING SPACER PART NUMBER 126216.



MICROWAVE CORPORATION v00.0612

HMC-C088

SUCCESSIVE DETECTION LOG VIDEO AMPLIFIER (SDLVA) 1 - 20 GHz

Pin Descriptions

Pin Number	Function	Description	Interface Schematic
1	RFIN	RF Input pin.	
2, 3	GND	These pins must be connected to a high quality RF/DC ground.	
4	VIDEO OUT	Video Out is a voltage that is proportional to the log of the Input Power.	
5	N/C	The pins are not connected internally; however, all data shown herein was measured with these pins connected to RF/DC ground externally.	
6	Vdc	Bias Supply pin.	