

## Excellent Integrated System Limited

Stocking Distributor

Click to view price, real time Inventory, Delivery & Lifecycle Information:

[FCI](#)

[10119834-001LF](#)

For any questions, you can email us directly:

[sales@integrated-circuit.com](mailto:sales@integrated-circuit.com)

This document is the property of and embodies CONFIDENTIAL and PROPRIETARY information of FCI. No part of the information shown on this document may be used in any way or disclosed to others without the written consent of FCI. Copyright FCI.



FCI CONFIDENTIAL

PART NUMBER  
10119834-001LF

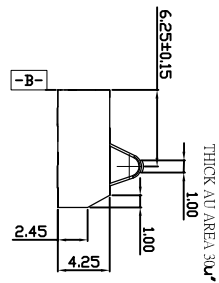
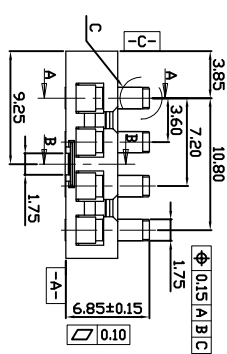
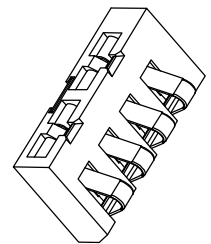
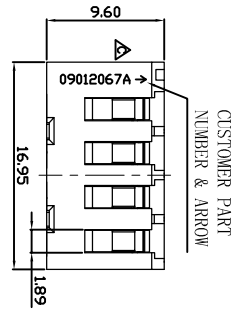
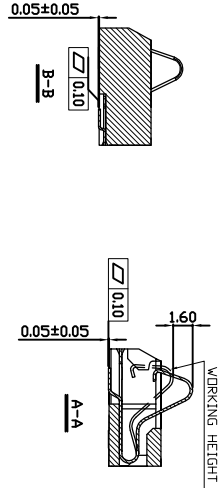
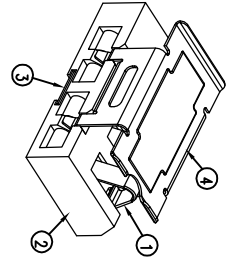

- NOTES:
1. MATERIAL: HOUSING: LCP, UL94 V-0, COLOR: NATURAL. TERMINAL: Ti-CU. CAP: STAINLESS STEEL. BOARDLOCK: STAINLESS STEEL.
  2. FINISH: TERMINAL: CONTACT AREA: GOLD PL.30μ" THK.MIN. ALL AREA: GOLD PL.1μ" THK.MIN. UNDER PLINICKEL PL.50μ" THK.MIN. BOARDLOCK: ALL AREA: GOLD PL.1μ" THK.MIN. UNDER PLINICKEL PL.50μ" THK.MIN.
  3. NORMAL FORCE : 0.85N Min. FOR 0.90mm COMPRESSION .
  4. CAP RETENTION FORCE : 9.8N Min.
  5. THE PRODUCT SPEC. PLS. REFER TO SS-12-674
  6. THE PACKAGING SPEC. PLS. REFER TO SS-14-1545
  7. THIS CONNECTOR CAN WITHSTAND EXPOSURE TO 260°C PEAK TEMPERATURE FOR 10 SECONDS IN IR BELOW OPEN.
  8. THE SUFFIX "LF" MEANS FOR LEAD FREE PROCESS.

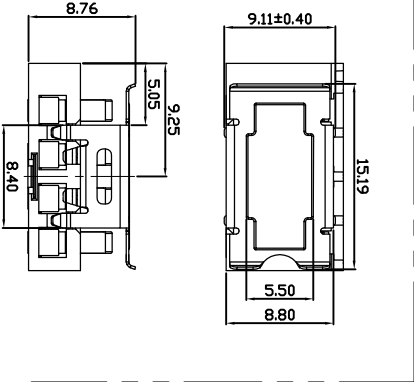
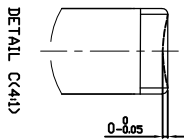
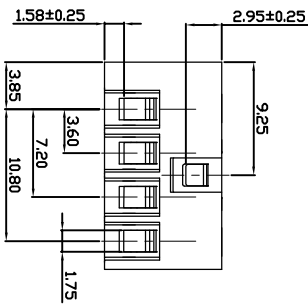
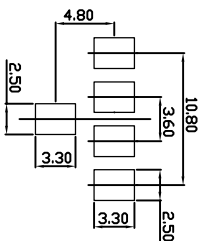

NO.	DESCRIPTION	QTY
4	CAP	1PCS
3	BOARD LOCK	1PCS
2	HOUSING	1PCS
1	TERMINAL	4PCS

TOLERANCES UNLESS OTHERWISE SPECIFIED	
4	± 0.25
3	± 0.15
2	± 0.10
1	± 0.10

DATE	HT ZHANG	2012-05-10
ENG	HT ZHANG	2012-05-10
CHK	HT ZHANG	2012-05-10
APP	PM ZHENG	2012-05-10

PROJECTION	product family
	MOBILE

SIZE	A4	SCALE	1 : 1
ECN NO.		REL LEVEL	
REV		DATE	
A	NEW	HT	2012-05-10
B	ELX-10-012525	VL	2012-08-15
C	ELX-10-012610	VL	2012-08-24

www.fci.com cat. no. 4PIN 3.60mm PITCH BATTERY MOBILE BATTERY CONNECTOR Customer Drawing 10119834 rev C sheet 1/1