

Excellent Integrated System Limited

Stocking Distributor

Click to view price, real time Inventory, Delivery & Lifecycle Information:

[FCI](#)
[10085176-220PLF](#)

For any questions, you can email us directly:
sales@integrated-circuit.com

PRODUCT NO.

SEE TABLE

10085176 - XXX - LF

- LEAD FREE
- PACKAGING OPTION NOTE 8, OMIT IF NOT REQUIRED.
- NO. OF POSITIONS PER ROW
- PLATING CODE
- BASE PART NUMBER

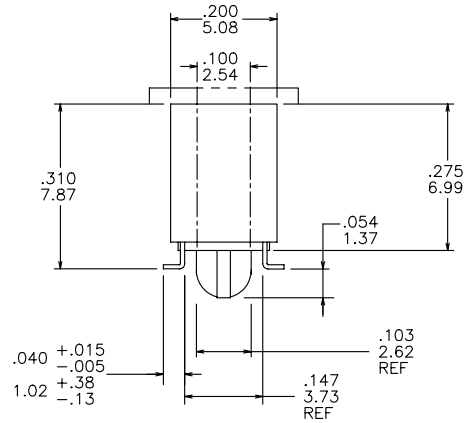
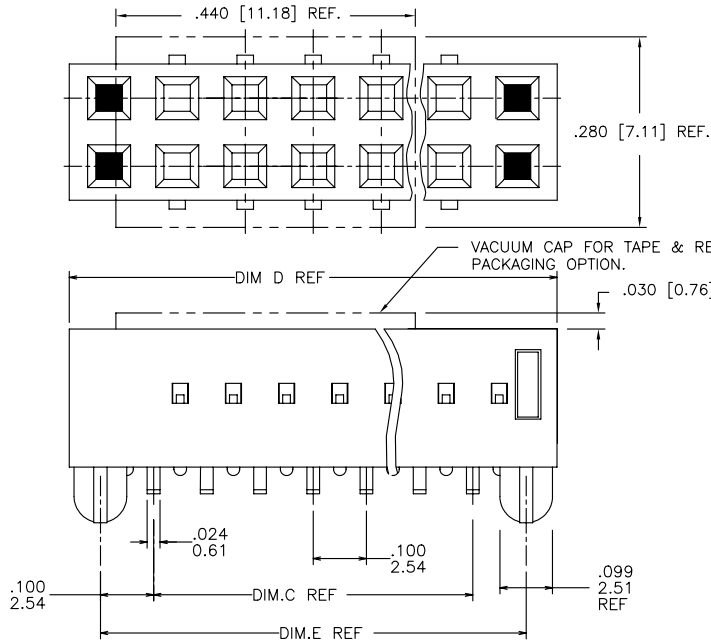

mat'l. code	surface	tolerance	projection	product family
NOTES 1,3,8 & 12	ISD 1302 ✓	ISD 406 ISD 1105		DUBOX
ltr ecn n d r date	tolerances unless otherwise specified			title
A M08-0072 MHT 2/17/07	XXX/01/2403			SMT DOUBLE ROW VCC ASSEMBLY
B EX-N-1488 ZK 06/03/13	angles line	XXX/005/XXX/13 XXX/000/XXX/05	scale 1:1	dwg no sheet 1 of 6 size
	dr M.HERNANDEZ 2/17/07			10085176 A3
	enr ALLUGO 2/17/07			type Product Customer Drawing
	chr ALLUGO 2/17/07			
	app ALLUGO 2/17/07			
sheet revision	B B B B B B			
index sheet	1 2 3 4 5 6			

4 PDS: Rev :B

STATUS: Released

Printed: Jun 10, 2013

PRODUCT NUMBER
SEE TABLE

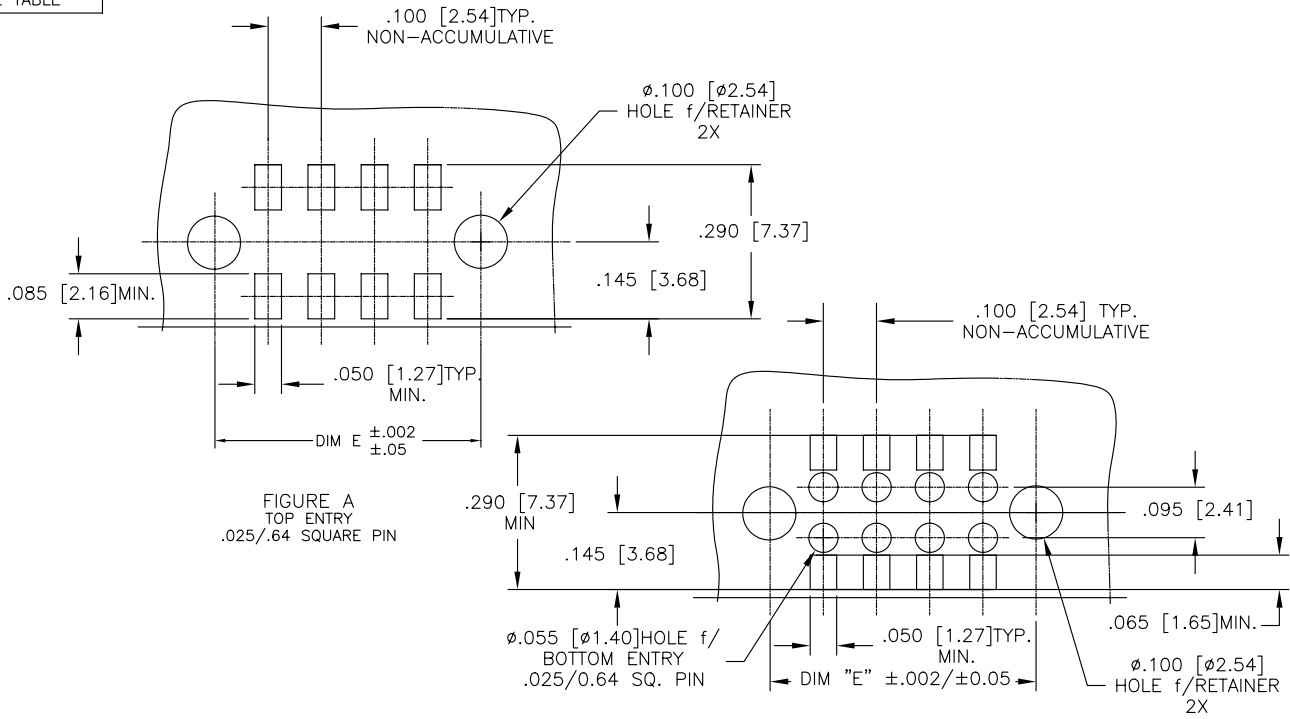

mat'l. code	surface	tolerance	projection	product family
NOTES 1,3,8 & 12	ISD 1302	ISD 406		DUBOX
tr/ecn nopr date	tolerances unless otherwise specified	ISD 1109		title
B	angles	0.01/0.03	INCH/MM	SMT DOUBLE ROW
	linea	0.003/0.005/0.008/0.01	scale 1:1	VCC ASSEMBLY
	dr	M.HERNANDEZ 2/17/07		dwg no
	enrg	ALLUGO 2/17/07		sheet2of6 size
	chr	ALLUGO 2/17/07		10085176 A3
	app	ALLUGO 2/17/07		type Product Customer Drawing
sheet	revision			
index	sheet			

PRODUCT NO.
SEE TABLE

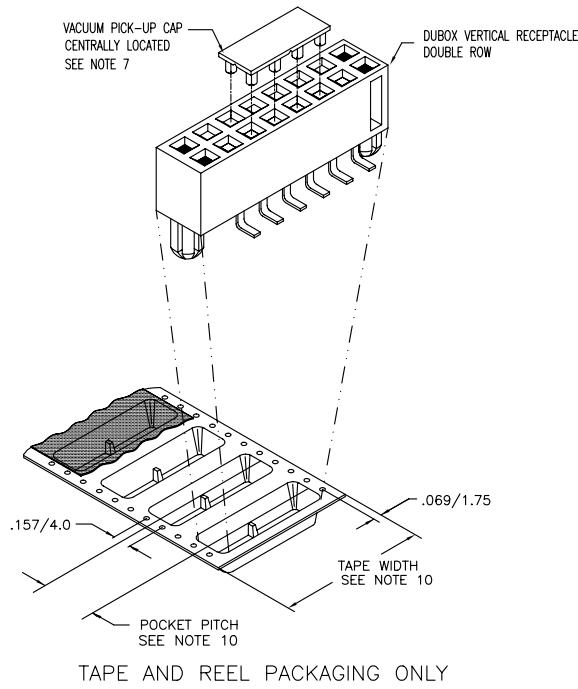

mat'l. code	surface	tolerance	projection	product family
NOTES 1,3,8 & 12	ISD 1302 ✓	ISD 406 ISD 1105		DUBOX
tr/ecn no/dr date	tolerances unless otherwise specified	line	INCH/MM	title
B	0±2"	XXX/XXX/XXX/13 XXX/XXX/XXX/06	scale 1:1	SMT DOUBLE ROW VCC ASSEMBLY
	dr	M.HERNANDEZ 2/17/07		dwg no
	enr	ALLUGO 2/17/07		sheet3of6 size
	chr	ALLUGO 2/17/07		10085176 A3
	app	ALLUGO 2/17/07		type Product Customer Drawing
sheet	revision			
index	sheet			

4 PDS: Rev :B

STATUS: Released

Printed: Jun 10, 2013

PRODUCT NO NOTE 11	PLATING CONTACT AREA	PLATING SOLDER TAIL	MATERIAL REF
10085176-2XXLF	15u"/.38u Au MIN OVER 50u"/1.27u Ni MIN SEE NOTE 14	100u"/160u SN 2.54u/4.06u	NOTE 3 & 4
10085176-3XXLF	30u"/.76u Au MIN OVER 50u"/1.27u Ni MIN SEE NOTE 14	100u"/160u SN 2.54u/4.06u	NOTE 3 & 4
10085176-6XXLF	30u"/.76u Au MIN OVER 50u"/1.27u Ni MIN SEE NOTE 14	100u"/160u SN 2.54u/4.06u	NOTE 3 & 4

NOTES:

- ① MATERIAL TERMINAL: PHOSPHOR BRONZE,
2. RECOMMENDED APPLICATION DATA:
 - A. RECOMMENDED SOLDER PAD PATTERN IS SHOWN IN FIGURE A & B.
 - B. ALL MATING PINS TO BE .025/.64. SQUARE ON TRUE CENTER OF GIVEN TERMINAL SPACING WITHIN .015/.38. DIA.
 - C. SUGGESTED MATING PIN LENGTH .210 ±.020/5.33 ±.51.
- ③ MATERIAL HOUSING: P.P.S. FILLED,COLOR BLACK FLAME RETARDANT PER UL 94V-0. COMPATIBLE WITH INFRA-RED SOLDERING. THIS PART WILL WITHSTAND EXPOSURES TO 260°C PEAK TEMPERATURE FOR 20 SECONDS IN WAVE SOLDER, INFRA-RED OR VAPOR PHASE SOLDER PROCESS.
- ④ PRESTAMPED POST PLATED TERMINALS.
5. FCI, FCI FINAL PART NUMBER AND DATE CODE TO BE MARKED ON TUBE LABEL.
6. CARRIER TAPE WIDTH 24 MIN. & BELOW TO HAVE PILOT HOLES ON ONE SIDE OF TAPE ONLY. SIZES ABOVE 24mm TO HAVE PILOT HOLES ON BOTH SIDES OF TAPE.
- ⑦ VACUUM CAP MATERIAL FOR TAPE & REEL PACKAGING: L.C.P., FLAME RETARDANT PER UL 94V-0. COLOR: BLACK
- ⑧ ADD SUFFIX "P" TO PART DASH NUMBER FOR TAPE AND REEL PACKAGING. EXAMPLE: 10085176-XXXP
9. MAXIMUM LENGTH OF CONNECTOR FOR TAPE AND REEL PACKAGING IS 2.50 INCHES LONG/63.5 MM.
- ⑩ TAPE & REEL PACKAGING 72mm WIDE TAPE WITH 16mm POCKET PITCH.
- ⑪ PART NUMBER WITH "LF" SUFFIX AT THE END ARE LEAD FREE.
12. THESE PRODUCTS MEETS EUROPEAN UNION DIRECTIVES AND OTHER COUNTRY REGULATION AS DESCRIBED IN GS-22-008.
- ⑬ "THIS PRODUCT HAS 100%% TIN PLATING IN THE INTERFACE AND HAS NOT BEEN TESTED FOR WHISKER GROWTH IN ALL INTERCONNECT ENVIRONMENTS."
- ⑭ PLATING OPTIONS:
MAY BE EITHER GOLD OR GXT PLATED AT MANUFACTURER'S OPTION.

mat'l. code	surface	tolerance	projection	product family
NOTES 1,3,8 & 12	ISO 1302	ISO 405		DUBOX
ltr/ecn naddr date	tolerances unless otherwise specified	ISO 1101		title
B	angles	XX.X/XX.X		SMT DOUBLE ROW
	0±2'	XX.X/XX.X/XX.X/XX.X	INCH/MM	VCC ASSEMBLY
	line	XX.X/XX.X/XX.X/XX.X	scale 1:1	dwg no
	dr	M.HERNANDEZ 2/17/07		sheet 4 of 6 size
	enr	ALLUGO 2/17/07		10085176 A3
	chr	ALLUGO 2/17/07		type Product Customer Drawing
	app	ALLUGO 2/17/07		
sheet index	revision sheet			

PRODUCT NO	NO OF POS	DIM C	DIM D	DIM E	TAPE & REEL PACKAGING	LEAD FREE
10085176-Y02LF	2 X 2	.100/2.54	.417/10.59	.300/7.62	NO	
10085176-Y03LF	2 X 3	.200/5.08	.517/13.13	.400/10.16	NO	
10085176-Y04LF	2 X 4	.300/7.62	.617/15.67	.500/12.70	NO	
10085176-Y05LF	2 X 5	.400/10.16	.717/18.21	.600/15.24	NO	
10085176-Y06LF	2 X 6	.500/12.70	.817/20.75	.700/17.78	NO	
10085176-Y07LF	2 X 7	.600/15.24	.917/23.29	.800/20.32	NO	
10085176-Y08LF	2 X 8	.700/17.78	1.017/25.83	.900/22.86	NO	
10085176-Y09LF	2 X 9	.800/20.32	1.117/28.37	1.000/25.40	NO	
10085176-Y10LF	2 X 10	.900/22.86	1.217/30.91	1.100/27.94	NO	
10085176-Y11LF	2 X 11	1.000/25.40	1.317/33.45	1.200/30.48	NO	
10085176-Y12LF	2 X 12	1.100/27.94	1.417/35.99	1.300/33.02	NO	
10085176-Y13LF	2 X 13	1.200/30.48	1.517/38.53	1.400/35.56	NO	
10085176-Y14LF	2 X 14	1.300/33.02	1.617/41.07	1.500/38.10	NO	
10085176-Y15LF	2 X 15	1.400/35.56	1.717/43.61	1.600/40.64	NO	
10085176-Y16LF	2 X 16	1.500/38.10	1.817/46.15	1.700/43.18	NO	
10085176-Y17LF	2 X 17	1.600/40.64	1.917/48.69	1.800/45.72	NO	
10085176-Y18LF	2 X 18	1.700/43.18	2.017/51.23	1.900/48.26	NO	
10085176-Y19LF	2 X 19	1.800/45.72	2.117/53.77	2.000/50.80	NO	
10085176-Y20LF	2 X 20	1.900/48.26	2.217/56.31	2.100/53.34	NO	
10085176-Y20PLF	2 X 20	1.900/48.26	2.217/56.31	2.100/53.34	YES -- NOTE 8 & 10	
10085176-Y21LF	2 X 21	2.000/50.80	2.317/58.85	2.200/55.08	NO	
10085176-Y22LF	2 X 22	2.100/53.34	2.417/61.39	2.300/58.42	NO	
10085176-Y23LF	2 X 23	2.200/55.88	2.517/63.93	2.400/60.96	NO	
10085176-Y24LF	2 X 24	2.300/58.42	2.617/66.47	2.500/63.50	NO	
10085176-Y25LF	2 X 25	2.400/60.96	2.717/69.01	2.000/66.04	NO	

NOTE 11

mat'l. code	surface	tolerance	projection	product family
NOTES 1,3,8 & 12	ISO 1302 ✓	ISO 406	ASME Y14.5	DUBOX
tr/ecn nopr date	tolerances unless otherwise specified	ISO 1101	1st angle	title
B	0±2°	XXX.XXX/XXX.XX	INCH/MM	SMT DOUBLE ROW
	line	XXX.XXX/XXX.XX	scale 1:1	VCC ASSEMBLY
	dr	M.HERNANDEZ 2/17/07		dwg no
	enr	ALLUGO 2/17/07		sheet 5 of 6
	chr	ALLUGO 2/17/07		size
	app	ALLUGO 2/17/07		A3
sheet index	revision sheet			type Product Customer Drawing

FCI FCIconnect.com Copyright FCI

PRODUCT NO	NO OF POS	DIM C	DIM D	DIM E	TAPE & REEL PACKAGING	LEAD FREE
10085176-Y26LF	2 X 26	2.500/63.50	2.817/71.55	2.700/68.58	NO	
10085176-Y27LF	2 X 27	2.600/66.04	2.917/74.09	2.800/71.12	NO	
10085176-Y28LF	2 X 28	2.700/68.58	3.017/76.63	2.900/73.66	NO	
10085176-Y29LF	2 X 29	2.800/71.12	3.117/79.17	3.000/76.20	NO	
10085176-Y30LF	2 X 30	2.900/73.66	3.217/81.71	3.100/78.74	NO	
10085176-Y31LF	2 X 31	3.000/76.20	3.317/84.25	3.200/81.28	NO	
10085176-Y32LF	2 X 32	3.100/78.74	3.417/86.79	3.300/83.32	NO	
10085176-Y33LF	2 X 33	3.200/81.28	3.517/89.33	3.400/86.36	NO	
10085176-Y34LF	2 X 34	3.300/83.32	3.617/91.87	3.500/88.90	NO	
10085176-Y35LF	2 X 35	3.400/86.36	3.717/94.41	3.600/91.44	NO	
10085176-Y36LF	2 X 36	3.500/88.90	3.817/96.95	3.700/93.98	NO	
10085176-Y37LF	2 X 37	3.600/91.44	3.917/99.49	3.800/96.52	NO	
10085176-Y38LF	2 X 38	3.700/93.98	4.017/102.03	3.900/99.06	NO	
10085176-Y39LF	2 X 39	3.800/96.52	4.117/104.57	4.000/101.60	NO	
10085176-Y40LF	2 X 40	3.900/99.06	4.217/107.11	4.100/104.14	NO	
10085176-Y41LF	2 X 41	4.000/101.60	4.317/109.65	4.200/106.68	NO	
10085176-Y42LF	2 X 42	4.100/104.14	4.417/112.19	4.300/109.22	NO	
10085176-Y43LF	2 X 43	4.200/106.68	4.517/114.73	4.400/111.76	NO	
10085176-Y44LF	2 X 44	4.300/109.22	4.617/117.27	4.500/114.30	NO	
10085176-Y45LF	2 X 45	4.400/111.76	4.717/119.81	4.600/116.84	NO	
10085176-Y46LF	2 X 46	4.500/114.30	4.817/122.35	4.700/119.38	NO	
10085176-Y47LF	2 X 47	4.600/116.84	4.917/124.89	4.800/121.92	NO	
10085176-Y48LF	2 X 48	4.700/119.38	5.017/127.43	4.900/124.46	NO	
10085176-Y49LF	2 X 49	4.800/121.92	5.117/129.97	5.000/127.00	NO	
10085176-Y50LF	2 X 50	4.900/124.46	5.217/132.51	5.100/129.54	NO	
10085176-Y16PLF	2 X 16	1.500/38.10	1.817/46.15	1.700/43.18	YES -- NOTE 8 & 10	

NOTE 11

mat'l code	surface	tolerance	projection	product family
NOTES 1,3,8 & 12	ISO 1302 ✓	ISO 406		DUBOX
tr/ecn nopr date	tolerances unless otherwise specified	ISO 1101		title
B	angles	XXX.X/XXX.X	INCH/MM	SMT DOUBLE ROW
	line	XXX.X/XXX.X	scale 1:1	VCC ASSEMBLY
	dr	M.HERNANDEZ 2/17/07		dwg no
	enr	ALLUGO 2/17/07		sheet 6 of 6 size
	chr	ALLUGO 2/17/07		10085176 A3
	app	ALLUGO 2/17/07		type Product Customer Drawing
sheet	revision			
index	sheet			

4 PDS: Rev :B

STATUS: Released

Printed: Jun 10, 2013