

Excellent Integrated System Limited

Stocking Distributor

Click to view price, real time Inventory, Delivery & Lifecycle Information:

[FCI](#)

[91687-302LF](#)

For any questions, you can email us directly:

sales@integrated-circuit.com

PRODUCT NUMBER
91687-YXXLF

RoHS COMPATIBLE, SEE NOTE 7

PLATING _____

NUMBER OF POSITIONS PER ROW : 02 TO 36

3=0.76µm GOLD/GXT ON CONTACT AREA
2 µm MIN MATTE TIN ON TAIL
1.27µm Ni MIN UNDERPLATING

NOTES:

1. BODY MATERIAL: POLYESTER 30% GLASSFILLED COLOR BLUE, FLAME RETARDANT PER UL-94 V0.
2. CONTACT MATERIAL: PHOSPHOR BRONZE.
3. 15N MIN PIN RETENTION IN EITHER DIRECTION
4. 0.6 MAX PROTRUSION PERMITTED AT 4 PLACES
5. PACKAGING :
- POLYBAGS FROM 2 x 02 TO 2 x 06 POSITIONS
- TUBE FROM 2 x 07 TO 2 x 36 POSITIONS
6. TO DETERMINE DIMENSIONS :
N = NUMBER OF POSITIONS PER ROW
EXAMPLE : 8 POS N x 2.54 = 20.32mm
7. RoHS COMPATIBLE PRODUCT SPECIFICATIONS
 - a - PLATING:
- "LF" MEANS THE PRODUCT IS LEAD-FREE,
2µm MINIMUM MATTE TIN OVER 1.27µm
MINIMUM NICKEL UNDERPLATE.
 - b - MANUFACTURING PROCESS COMPATIBILITY
- THE HOUSING WILL WITHSTAND EXPOSURE TO
245°C ±5°C SOLDER BATH TEMPERATURE FOR
5 SECONDS IN A WAVE SOLDER APPLICATION
WITH A 1.6mm MIN THICK CIRCUIT BOARD.
 - c - LABELING:
- MEETS PACKAGING SPECS AS PER GS-14-920
 - d - LEGAL STATEMENT: SEE GS-47-0004

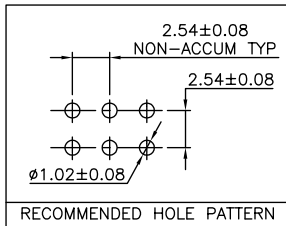
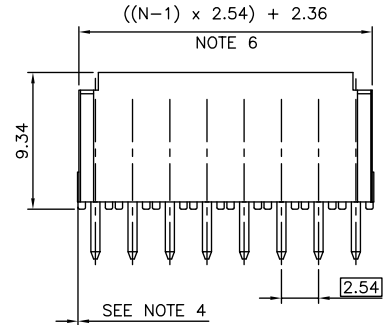
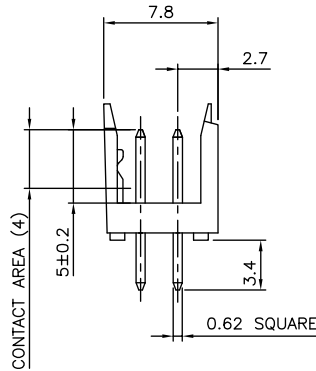
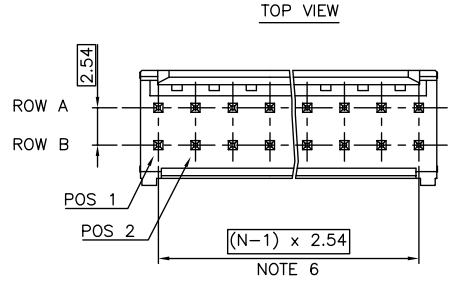

mat'l. code	surface	tolerance	projection	product family
SEE NOTES	ISO 1302 ✓	ISO 446 ISO 1101	mm	DUBOX HDR
ltr	ec'n no	dr	date	title
B	F00190	LMU	00.04.12	DUBOX HEADER
C	F05-0117	LMU	05.01.31	STRAIGHT, DOUBLE ROW
D	F05-0244	JCO	05.09.06	dwg no
E	F06-0228	LMU	06.07.11	sheet 1 of 1
F	F08-0147	YOV	08.04.14	size
G	B-19285	AMA	14.11.03	A3
H	F-21810	AMA	15.06.19	type
		app	JMC	CUSTOMER Drawing
sheet	revision			
index	sheet			