



April 2015

FSA553

Dual SPST Depletion Audio Switch with Negative Swing

Features

- Dual SPST Depletion Switch
- Normally Closed when $V_{CC} < 0.2\text{ V}$
- Switches Configurable through Select Pins
- V_{SW} : -1.5 V to +1.5 V
- R_{ON} : 0.4 Ω (Typical)
- $R_{FLAT} < 0.01\ \Omega$ (Typical)
- THD+N: -104 dB (Typical)
- OIRR: -78 dB (Typical)

Description

The FSA553 is a high-performance dual single-pole single-throw (SPST x 2) audio switch. The Depletion technology allows the device to conduct signals when there is no V_{CC} available and to isolate signals when V_{CC} is present. During signal conduction, the Depletion gate control allows the FSA553 to achieve excellent THD+N performance while consuming minimal power.

Related Resources

- FSA553 Evaluation Board

Applications

- Smart Phones
- Tablets, Ultra Books

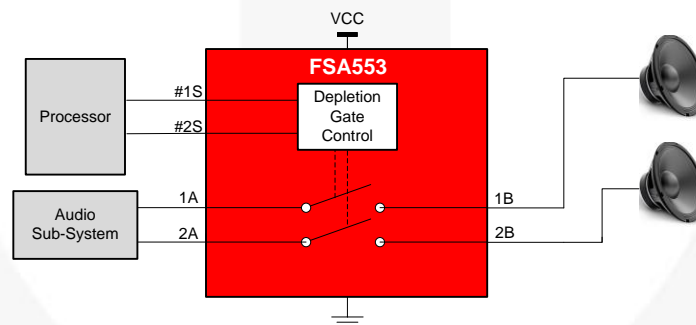

Figure 1. Application Block Diagram

Ordering Information

Part Number	Operating Temperature Range	Top Mark	Package	Packing Method
FSA553UCX	-40 to 85°C	NG	9-Ball WLCSP, 0.40 mm Pitch, 1.215 x 1.385 x 0.58 mm (Nominal)	3000 Units on Tape & Reel

Pin Configuration

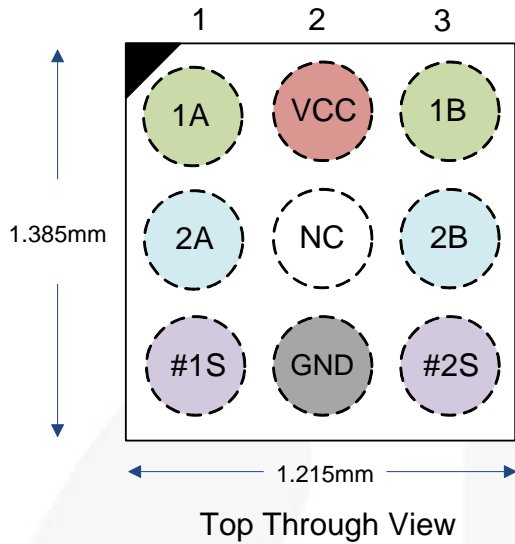

Figure 2. Top Through View

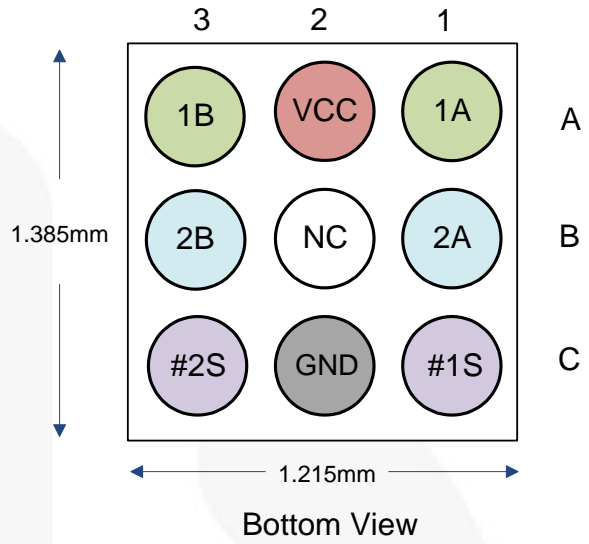

Figure 3. Bottom View

Pin Descriptions

Pin #	Name	Type	Description
A1	1A	Depletion I/O	A-Port of Switch 1 (Normally Closed)
A3	1B	Depletion I/O	B-Port of Switch 1 (Normally Closed)
C1	#1S	Control	Select to Enable/Disable SW1 (Enable LOW)
A2	V _{CC}	Power Supply / Control	Power Supply Input
B2	NC	No Connect	Do Not Connect
C2	GND	Ground	Ground
B1	2A	Depletion I/O	A-Port of Switch 2 (Normally Closed)
B3	2B	Depletion I/O	B-Port of Switch 2 (Normally Closed)
C3	#2S	Control	Select to Enable/Disable SW2 (Enable LOW)

Table 1. Switch Truth Table

V _{CC}	#1S	#2S	Switch 1	Switch 2
LOW	X	X	ON	ON
HIGH	HIGH	HIGH	OFF	OFF
HIGH	LOW	HIGH	ON	OFF
HIGH	HIGH	LOW	OFF	ON

Absolute Maximum Ratings

Stresses exceeding the absolute maximum ratings may damage the device. The device may not function or be operable above the recommended operating conditions and stressing the parts to these levels is not recommended. In addition, extended exposure to stresses above the recommended operating conditions may affect device reliability. The absolute maximum ratings are stress ratings only.

Symbol	Parameter		Min.	Max.	Unit
V _{CC}	Supply/Control Voltage		-0.5	4.3	V
V _{CNTRL}	Select Input Voltage	#1S, #2S	-0.5	4.3	V
V _{SW(ON)}	DC Switch I/O Voltage (Switch Conducting)	1A, 1B, 2A, 2B	-2.0	2.0	V
V _{SW(OFF)}	DC Switch I/O Voltage (Switch Isolated)	1A, 1B, 2A, 2B	-2.0	2.0	V
I _{SW}	Switch I/O Current	V _{CC} =0 V (Switch Conducting)		350	mA
I _{SWPEAK}	Peak Switch Current	Pulsed at 1 ms Duration, <10% Duty Cycle		500	mA
ESD	Human Body Model, ANSI/ESDA/JEDEC JS-001-2012	I/O Ports		7	kV
		All Other Pins		4	
	Charged Device Model, JEDEC: JESD22-C101			2	
	IEC 61000-4-2 System	Contact		8	
		Air Gap		15	
T _A	Absolute Maximum Operating Temperature		-40	+85	°C
Θ _{JA}	Thermal Resistance, Junction-to-Ambient	2S2P JEDEC std. PCB		97	°C/W
T _{STG}	Storage Temperature		-65	+150	°C

Recommended Operating Conditions

The Recommended Operating Conditions table defines the conditions for actual device operation. Recommended operating conditions are specified to ensure optimal performance to the datasheet specifications. Fairchild does not recommend exceeding these ratings or designing to Absolute Maximum Ratings.

Symbol	Parameter		Min.	Max.	Unit
V _{CC(ON)}	Supply Voltage with Depletion Switch Conducting (1A=1B; 2A=2B)		0	0.2	V
V _{CC(OFF)}	Supply Voltage with Depletion Switch Isolated (1A≠1B; 2A≠2B; #1S=#2S=HIGH)		1.5	3.0	V
V _{SW(ON)}	DC Switch I/O Voltage	Switch Conducting	-1.5	1.5	V
V _{SW(OFF)}	DC Switch I/O Voltage	Switch Isolated	-1.5	1.5	V
V _{CNTRL}	Select Input Voltage	#1S, #2S	0	3.0	V

DC Electrical Characteristics

Unless otherwise specified, typical values are for $T_A=25^\circ\text{C}$.

Symbol	Parameter	Condition	V_{CC} (V)	$T_A=-40^\circ\text{C}$ to $+85^\circ\text{C}$			Unit
				Min.	Typ.	Max.	
$V_{CC(HYS)}$	Supply Voltage Hysteresis				450		mV
I_{ON}	Switch ON Leakage Current	nA=-0.5 V, 0.5 V, 1.5 V, -1.5 V, nB=Float, #1S=#2S=Float	0		0.1		μA
I_{OFF}	Switch OFF Leakage Current	nA=-0.5 V, 0.5 V, 1.5 V, -1.5 V, nB=GND, #1S=#2S= V_{CC}	1.8		0.5		μA
I_{CCT}	Increase in I_{CC} for each Select Pin	#1S= V_{CC} , #2S=1.2 V, #1S=1.2 V, #2S= V_{CC}	3.0		7		μA
R_{ON}	Switch On Resistance	$I_{SW}=100\text{ mA}$, $V_{SW}=-1.5\text{ V}$ to $+1.5\text{ V}$	0		0.40	0.80	Ω
ΔR_{ON}	Switch On Resistance Difference, Channel to Channel	$I_{SW}=100\text{ mA}$, $V_{SW}=-1.5\text{ V}$ to $+1.5\text{ V}$	0		0.01		Ω
$R_{FLAT(ON)}$	On Resistance Flatness	$I_{SW}=100\text{ mA}$, $V_{SW}=-1.5\text{ V}$ to $+1.5\text{ V}$	0		0.01		Ω
R_{PD}	V_{CC} Pull-Down Resistance		<0.2		5.0		M Ω
R_{PU}	Select Pull-Up Resistance		<0.2		3.0		M Ω
I_{CC}	Quiescent Supply Current	#1S=#2S=0 V or Float	Switch Isolated	1.5 – 3.0	80		μA
			Switch Conducting	0.2	0.5		
V_{IH}	Select Pin Input High Voltage		1.5 – 3.0	1.2			V
V_{IL}	Select Pin Input Low Voltage		1.5 – 3.0			0.55	V

AC Electrical Characteristics

Unless otherwise specified, typical values are for $T_A=25^\circ\text{C}$.

Symbol	Parameter	Condition	V_{CC} (V)	$T_A=-40^\circ\text{C to }+85^\circ\text{C}$			Unit	
				Min.	Typ.	Max.		
t_{ON}	Turn-On Time V_{CC} to Output	$R_L=32\ \Omega$, $C_L=10\ \text{pF}$, #nS=Float, Figure 4	$V_{SW}=1.5\ \text{V}$	1.8 → 0		450	μs	
			$V_{SW}=-1.5\ \text{V}$	1.8 → 0		350		
t_{OFF}	Turn-Off Time V_{CC} to Output	$R_L=32\ \Omega$, $C_L=10\ \text{pF}$, #nS=Float, Figure 4	$V_{SW}=1.5\ \text{V}$	0 → 1.8		250	μs	
			$V_{SW}=-1.5\ \text{V}$	0 → 1.8		150		
t_{ONS}	Turn-On Time Select Pin	$R_L=32\ \Omega$, $C_L=10\ \text{pF}$, #nS= $V_{CC} \rightarrow 0$, Figure 5	$V_{SW}=1.5\ \text{V}$	1.8		350	μs	
			$V_{SW}=-1.5\ \text{V}$	1.8		300		
t_{OFFS}	Turn-Off Time Select Pin	$R_L=32\ \Omega$, $C_L=10\ \text{pF}$, #nS=0 → V_{CC} , Figure 5	$V_{SW}=1.5\ \text{V}$	1.8		150	μs	
			$V_{SW}=-1.5\ \text{V}$	1.8		50		
BW	-3 dB Bandwidth	$V_{SW}=600\ \text{mV}_{p-p}$, $R_L=50\ \Omega$; $C_L=5\ \text{pF}$,	0			200	MHz	
THD+N	Total Harmonic Distortion + Noise	$V_{SW}=1\ V_{RMS}$, $R_L=32\ \Omega$, $f=1\ \text{kHz}$	Non A-weighted	0		-104	dB	
			A-weighted			-107	dB	
O_{IRR}	Port Off Isolation	$V_{SW}=0.707\ V_{RMS}$, $R_L=32\ \Omega$, $f=20\ \text{Hz to }100\ \text{kHz}$, Figure 6	1.8	-70		-82	dB	
X_{TALK}	Cross Talk	$V_{SW}=1\ V_{RMS}$, $f=100\ \text{kHz}$, $R_L=32\ \Omega$	1.8			-75	dB	
		$V_{SW}=1\ V_{RMS}$, $f=20\ \text{kHz}$, $R_L=32\ \Omega$				-100		
PSRR	Power Supply Rejection Ratio	Switch Isolating, $V_{Ripple}=V_{CC}+300\ \text{mV}_{p-p}$, $R_L=32\ \Omega$	217Hz	1.8			-80	dB
			1 kHz				-77	
			20 kHz				-73	

Capacitance

Unless otherwise specified, typical values are for $T_A=25^\circ\text{C}$.

Symbol	Parameter	Condition	V_{CC} (V)	$T_A=-40^\circ\text{C to }+85^\circ\text{C}$			Unit
				Min.	Typ.	Max.	
C_{ON}	On Capacitance	$V_{SW}=400\ \text{mV}_{PP}$, $f=1\ \text{MHz}$,	0			21	pF
C_{OFF}	Off Capacitance	$V_{SW}=400\ \text{mV}_{PP}$, $f=1\ \text{MHz}$, #1S=#2S= V_{CC}	1.8			25	pF
C_{CTRL}	Select Pin Capacitance	#nS= $400\ \text{mV}_{PP}$, $f=1\ \text{MHz}$,	1.8			5	pF

Timing Diagrams

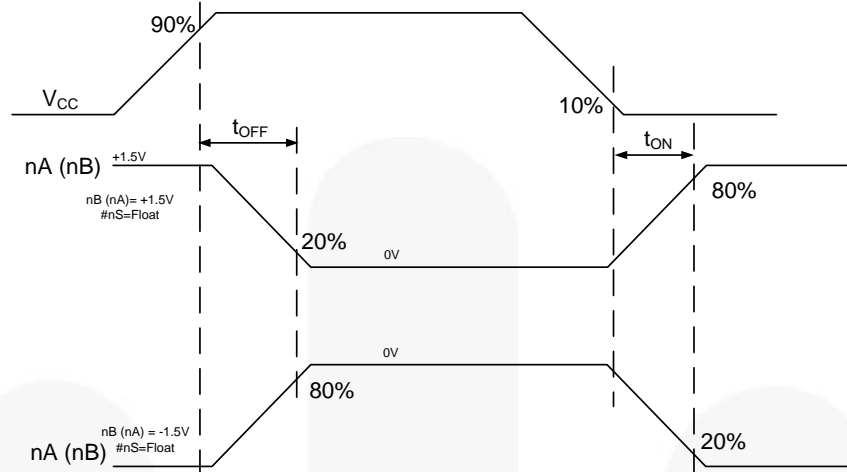

Figure 4. t_{ON}/t_{OFF} V_{CC} to Output Timing

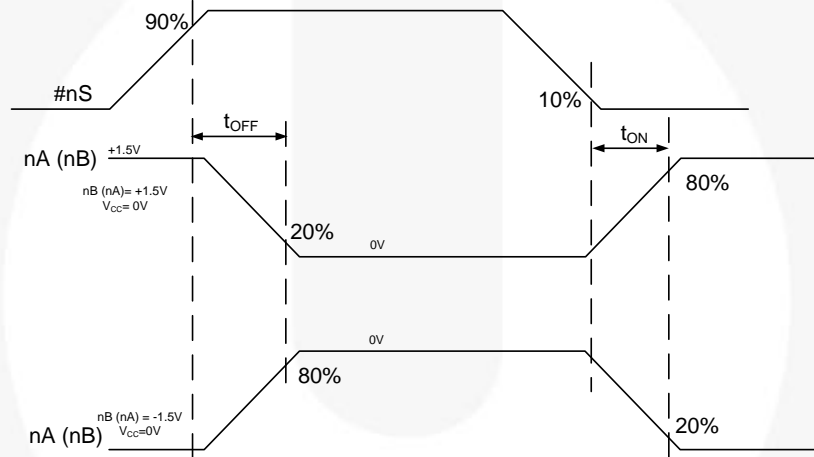
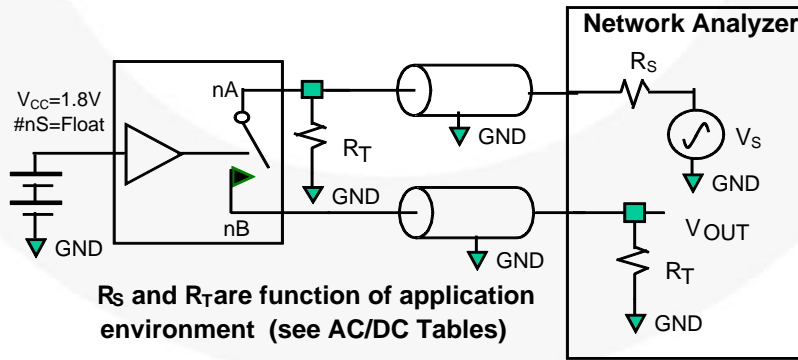

Figure 5. t_{ON}/t_{OFF} Select (#nS) to Output Timing



$$\text{OFF Isolation} = 20 \text{ Log } (V_{OUT}/V_{IN})$$

Figure 6. OFF Isolation

Product-Specific Dimensions

E	D	X	Y
1.215±.03 mm	1.385±.03 mm	0.2075 mm	0.2925 mm

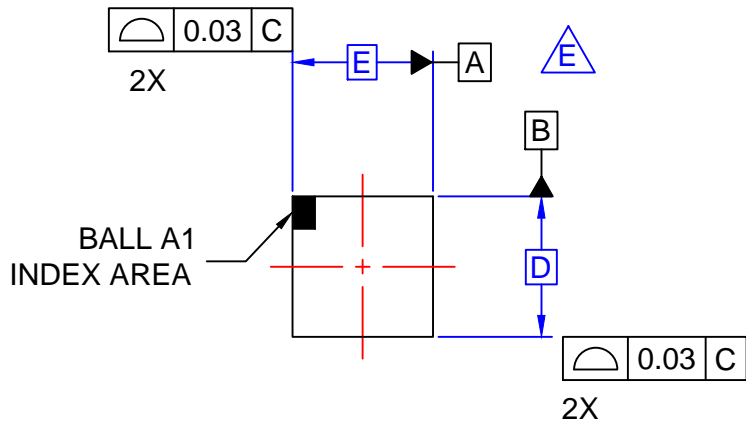

TOP VIEW

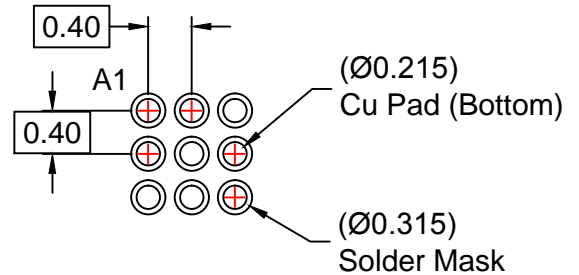

RECOMMENDED LAND PATTERN
(NSMD PAD TYPE)

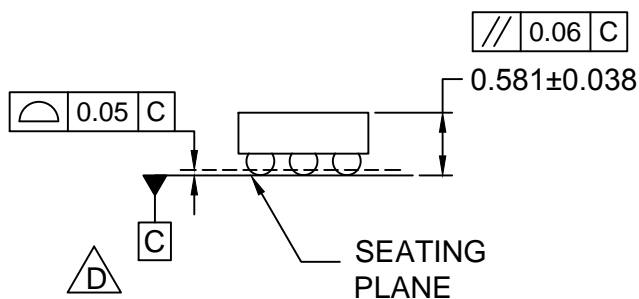

SIDE VIEWS

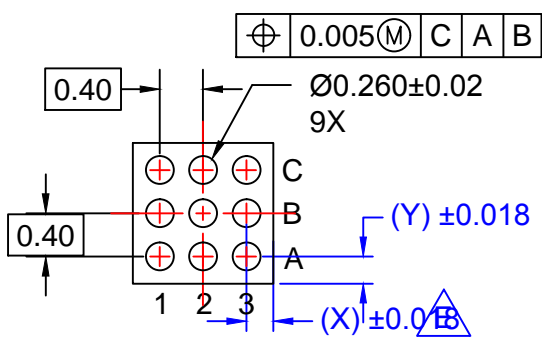
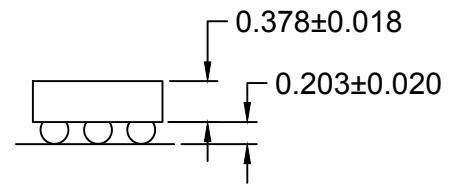

BOTTOM VIEW

NOTES

- A. NO JEDEC REGISTRATION APPLIES.
- B. DIMENSIONS ARE IN MILLIMETERS.
- C. DIMENSIONS AND TOLERANCE PER ASME Y14.5M, 2009.
- D. DATUM C IS DEFINED BY THE SPHERICAL CROWNS OF THE BALLS.
- E. FOR DIMENSIONS D, E, X, AND Y SEE PRODUCT DATASHEET.
- F. DRAWING FILNAME: MKT-UC009Ak rev2





TRADEMARKS

The following includes registered and unregistered trademarks and service marks, owned by Fairchild Semiconductor and/or its global subsidiaries, and is not intended to be an exhaustive list of all such trademarks.

- | | | | |
|--------------------------|--|---------------------------------------|------------------|
| AccuPower™ | F-PFS™ | OPTOPLANAR® | SYSTEM GENERAL® |
| AttitudeEngine™ | FRFET® | Power Supply WebDesigner™ | TinyBoost® |
| Awinda® | Global Power Resource™ | PowerTrench® | TinyBuck® |
| AX-CAP®* | GreenBridge™ | PowerXS™ | TinyCalc™ |
| BitSiC™ | Green FPS™ | Programmable Active Droop™ | TinyLogic® |
| Build it Now™ | Green FPS™ e-Series™ | QFET® | TINYOPTO™ |
| CorePLUS™ | Gmax™ | QS™ | TinyPower™ |
| CorePOWER™ | GTO™ | Quiet Series™ | TinyPWM™ |
| CROSSVOL™ | IntelliMAX™ | RapidConfigure™ | TinyWire™ |
| CTL™ | ISOPLANAR™ | Saving our world, 1mW/W/kW at a time™ | TranSiC™ |
| Current Transfer Logic™ | Making Small Speakers Sound Louder and Better™ | SignalWise™ | TriFault Detect™ |
| DEUXPEED® | MegaBuck™ | SmartMax™ | TRUECURRENT®* |
| Dual Cool™ | MICROCOUPLER™ | SMART START™ | μSerDes™ |
| EcoSPARK® | MicroFET™ | Solutions for Your Success™ | UHC® |
| EfficientMax™ | MicroPak™ | SPM® | Ultra FRFET™ |
| ESBC™ | MicroPak2™ | STEALTH™ | UniFET™ |
| F [®] | MillerDrive™ | SuperFET® | Vcx™ |
| Fairchild® | MotionMax™ | SuperSOT™-3 | VisualMax™ |
| Fairchild Semiconductor® | MotionGrid® | SuperSOT™-6 | VoltagePlus™ |
| FACT Quiet Series™ | MTi® | SuperSOT™-8 | XST™ |
| FACT® | MTx® | SupreMOS® | Xsens™ |
| FastvCore™ | MVN® | SyncFET™ | 仙童® |
| FETBench™ | mWSaver® | Sync-Lock™ | |
| FPS™ | OptoHiT™ | | |
| | OPTOLOGIC® | | |

* Trademarks of System General Corporation, used under license by Fairchild Semiconductor.

DISCLAIMER

FAIRCHILD SEMICONDUCTOR RESERVES THE RIGHT TO MAKE CHANGES WITHOUT FURTHER NOTICE TO ANY PRODUCTS HEREIN TO IMPROVE RELIABILITY, FUNCTION, OR DESIGN. TO OBTAIN THE LATEST, MOST UP-TO-DATE DATASHEET AND PRODUCT INFORMATION, VISIT OUR WEBSITE AT [HTTP://WWW.FAIRCHILDSEMI.COM](http://www.fairchildsemi.com). FAIRCHILD DOES NOT ASSUME ANY LIABILITY ARISING OUT OF THE APPLICATION OR USE OF ANY PRODUCT OR CIRCUIT DESCRIBED HEREIN; NEITHER DOES IT CONVEY ANY LICENSE UNDER ITS PATENT RIGHTS, NOR THE RIGHTS OF OTHERS. THESE SPECIFICATIONS DO NOT EXPAND THE TERMS OF FAIRCHILD'S WORLDWIDE TERMS AND CONDITIONS, SPECIFICALLY THE WARRANTY THEREIN, WHICH COVERS THESE PRODUCTS.

AUTHORIZED USE

Unless otherwise specified in this data sheet, this product is a standard commercial product and is not intended for use in applications that require extraordinary levels of quality and reliability. This product may not be used in the following applications, unless specifically approved in writing by a Fairchild officer: (1) automotive or other transportation, (2) military/aerospace, (3) any safety critical application – including life critical medical equipment – where the failure of the Fairchild product reasonably would be expected to result in personal injury, death or property damage. Customer's use of this product is subject to agreement of this Authorized Use policy. In the event of an unauthorized use of Fairchild's product, Fairchild accepts no liability in the event of product failure. In other respects, this product shall be subject to Fairchild's Worldwide Terms and Conditions of Sale, unless a separate agreement has been signed by both Parties.

ANTI-COUNTERFEITING POLICY

Fairchild Semiconductor Corporation's Anti-Counterfeiting Policy. Fairchild's Anti-Counterfeiting Policy is also stated on our external website, www.fairchildsemi.com, under Terms of Use

Counterfeiting of semiconductor parts is a growing problem in the industry. All manufacturers of semiconductor products are experiencing counterfeiting of their parts. Customers who inadvertently purchase counterfeit parts experience many problems such as loss of brand reputation, substandard performance, failed applications, and increased cost of production and manufacturing delays. Fairchild is taking strong measures to protect ourselves and our customers from the proliferation of counterfeit parts. Fairchild strongly encourages customers to purchase Fairchild parts either directly from Fairchild or from Authorized Fairchild Distributors who are listed by country on our web page cited above. Products customers buy either from Fairchild directly or from Authorized Fairchild Distributors are genuine parts, have full traceability, meet Fairchild's quality standards for handling and storage and provide access to Fairchild's full range of up-to-date technical and product information. Fairchild and our Authorized Distributors will stand behind all warranties and will appropriately address any warranty issues that may arise. Fairchild will not provide any warranty coverage or other assistance for parts bought from Unauthorized Sources. Fairchild is committed to combat this global problem and encourage our customers to do their part in stopping this practice by buying direct or from authorized distributors.

PRODUCT STATUS DEFINITIONS

Definition of Terms

Datasheet Identification	Product Status	Definition
Advance Information	Formative / In Design	Datasheet contains the design specifications for product development. Specifications may change in any manner without notice.
Preliminary	First Production	Datasheet contains preliminary data; supplementary data will be published at a later date. Fairchild Semiconductor reserves the right to make changes at any time without notice to improve design.
No Identification Needed	Full Production	Datasheet contains final specifications. Fairchild Semiconductor reserves the right to make changes at any time without notice to improve the design.
Obsolete	Not In Production	Datasheet contains specifications on a product that is discontinued by Fairchild Semiconductor. The datasheet is for reference information only.

Rev. I77