

Excellent Integrated System Limited

Stocking Distributor

Click to view price, real time Inventory, Delivery & Lifecycle Information:

[STMicroelectronics](#)

[STB28N65M2](#)

For any questions, you can email us directly:

sales@integrated-circuit.com



STB28N65M2, STF28N65M2, STP28N65M2, STW28N65M2

N-channel 650 V, 0.15 Ω typ., 20 A MDmesh™ M2 Power MOSFETs in D²PAK, TO-220FP, TO-220 and TO-247 packages

Datasheet - preliminary data

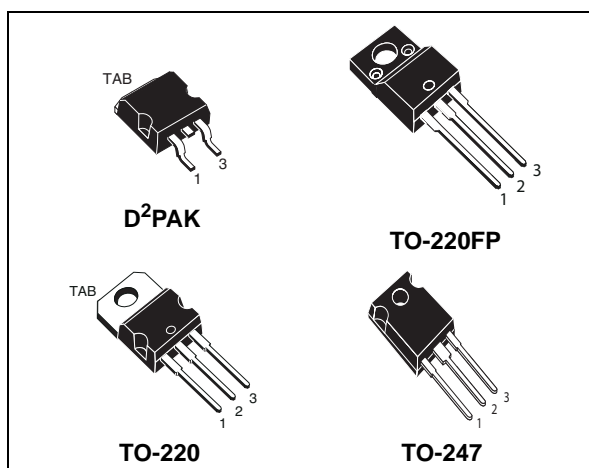
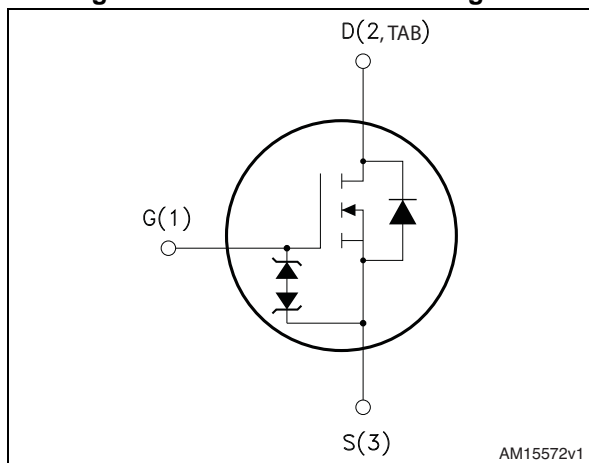

Figure 1. Internal schematic diagram



Features

Order codes	V _{DS}	R _{DS(on)} max	I _D
STB28N65M2	650 V	0.18 Ω	20 A
STF28N65M2			
STP28N65M2			
STW28N65M2			

- Extremely low gate charge
- Excellent output capacitance (C_{oss}) profile
- 100% avalanche tested
- Zener-protected

Applications

- Switching applications

Description

These devices are N-channel Power MOSFETs developed using MDmesh™ M2 technology. Thanks to their strip layout and improved vertical structure, the devices exhibit low on-resistance and optimized switching characteristics, rendering them suitable for the most demanding high efficiency converters.

Table 1. Device summary

Order codes	Marking	Package	Packaging
STB28N65M2	28N65M2	D ² PAK	Tape and reel
STF28N65M2		TO-220FP	Tube
STP28N65M2		TO-220	
STW28N65M2		TO-247	

Contents

1	Electrical ratings	3
2	Electrical characteristics	4
2.1	Electrical characteristics (curves)	6
3	Test circuits	9
4	Package mechanical data	10
4.1	D ² PAK, STB28N65M2	10
4.2	TO-220FP, STF28N65M2	13
4.3	TO-220, STP28N65M2	15
4.4	TO-247, STW28N65M2	17
5	Packing mechanical data	19
6	Revision history	21

STB28N65M2, STF28N65M2, STP28N65M2, STW28N65M2

Electrical ratings

1 Electrical ratings

Table 2. Absolute maximum ratings

Symbol	Parameter	Value		Unit
		D ² PAK, TO-220, TO-247	TO-220FP	
V _{GS}	Gate-source voltage	± 25		V
I _D	Drain current (continuous) at T _C = 25 °C	20	20 ⁽¹⁾	A
I _D	Drain current (continuous) at T _C = 100 °C	13	13 ⁽¹⁾	A
I _{DM} ⁽²⁾	Drain current (pulsed)	80		A
P _{TOT}	Total dissipation at T _C = 25 °C	170	30	W
V _{ISO}	Insulation withstand voltage (RMS) from all three leads to external heat sink (t = 1 s; T _C = 25 °C)	2500		V
dv/dt ⁽³⁾	Peak diode recovery voltage slope	15		V/ns
dv/dt ⁽⁴⁾	MOSFET dv/dt ruggedness	50		
T _{stg}	Storage temperature	- 55 to 150		°C
T _j	Max. operating junction temperature	150		

1. Current limited by package.
2. Pulse width limited by safe operating area.
3. I_{SD} ≤ 20 A, di/dt ≤ 400 A/μs; V_{DS peak} < V_{(BR)DSS}; V_{DD}=520 V
4. V_{DS} ≤ 520 V

Table 3. Thermal data

Symbol	Parameter	Value				Unit
		D ² PAK	TO-220FP	TO-220	TO-247	
R _{thj-case}	Thermal resistance junction-case max	0.74	4.17	0.74		°C/W
R _{thj-pcb} ⁽¹⁾	Thermal resistance junction-pcb max	30				°C/W
R _{thj-amb}	Thermal resistance junction-ambient max		62.5		50	°C/W

1. When mounted on 1 inch² FR-4, 2 Oz copper board

Table 4. Avalanche characteristics

Symbol	Parameter	Value	Unit
I _{AR}	Avalanche current, repetitive or not repetitive (pulse width limited by T _{jmax})	2.4	A
E _{AS}	Single pulse avalanche energy (starting T _j = 25°C, I _D = I _{AR} ; V _{DD} = 50 V)	760	mJ

Electrical characteristics

STB28N65M2, STF28N65M2, STP28N65M2, STW28N65M2

2 Electrical characteristics

($T_C = 25\text{ °C}$ unless otherwise specified)

Table 5. On /off states

Symbol	Parameter	Test conditions	Min.	Typ.	Max.	Unit
$V_{(BR)DSS}$	Drain-source breakdown voltage	$V_{GS} = 0, I_D = 1\text{ mA}$	650			V
I_{DSS}	Zero gate voltage drain current	$V_{GS} = 0, V_{DS} = 650\text{ V}$			1	μA
		$V_{GS} = 0, V_{DS} = 650\text{ V}$ $T_C = 125\text{ °C}$			100	μA
I_{GSS}	Gate-body leakage current	$V_{DS} = 0, V_{GS} = \pm 25\text{ V}$			± 10	μA
$V_{GS(th)}$	Gate threshold voltage	$V_{DS} = V_{GS}, I_D = 250\text{ }\mu\text{A}$	2	3	4	V
$R_{DS(on)}$	Static drain-source on-resistance	$V_{GS} = 10\text{ V}, I_D = 10\text{ A}$		0.15	0.18	Ω

Table 6. Dynamic

Symbol	Parameter	Test conditions	Min.	Typ.	Max.	Unit
C_{iss}	Input capacitance	$V_{DS} = 100\text{ V}, f = 1\text{ MHz},$ $V_{GS} = 0$	-	1440	-	pF
C_{oss}	Output capacitance		-	60	-	pF
C_{riss}	Reverse transfer capacitance		-	2	-	pF
$C_{oss\ eq}^{(1)}$	Equivalent output capacitance	$V_{GS} = 0, V_{DS} = 0\text{ to }520\text{ V}$	-	307	-	pF
R_G	Intrinsic gate resistance	$f = 1\text{ MHz}$ open drain	-	4.9	-	Ω
Q_g	Total gate charge	$V_{DD} = 520\text{ V}, I_D = 20\text{ A},$ $V_{GS} = 10\text{ V}$ (see Figure 19)	-	35	-	nC
Q_{gs}	Gate-source charge		-	6	-	nC
Q_{gd}	Gate-drain charge		-	15	-	nC

1. $C_{oss\ eq}$ is defined as a constant equivalent capacitance giving the same charging time as C_{oss} when V_{DS} increases from 0 to 80% V_{DSS}

Table 7. Switching times

Symbol	Parameter	Test conditions	Min.	Typ.	Max.	Unit
$t_{d(on)}$	Turn-on delay time	$V_{DD} = 325\text{ V}, I_D = 10\text{ A},$ $R_G = 4.7\text{ }\Omega, V_{GS} = 10\text{ V}$ (see Figure 18 and Figure 23)	-	13.4	-	ns
t_r	Rise time		-	10	-	ns
$t_{d(off)}$	Turn-off delay time		-	59	-	ns
t_f	Fall time		-	8.8	-	ns

STB28N65M2, STF28N65M2, STP28N65M2, STW28N65M2
Electrical characteristics
Table 8. Source drain diode

Symbol	Parameter	Test conditions	Min.	Typ.	Max.	Unit
I_{SD}	Source-drain current		-		20	A
$I_{SDM}^{(1)}$	Source-drain current (pulsed)		-		80	A
$V_{SD}^{(2)}$	Forward on voltage	$V_{GS} = 0, I_{SD} = 20\text{ A}$	-		1.6	V
t_{rr}	Reverse recovery time	$I_{SD} = 20\text{ A}, di/dt = 100\text{ A}/\mu\text{s}$ $V_{DD} = 60\text{ V}$ (see Figure 20)	-	384		ns
Q_{rr}	Reverse recovery charge		-	5.7		μC
I_{RRM}	Reverse recovery current		-	30		A
t_{rr}	Reverse recovery time	$I_{SD} = 20\text{ A}, di/dt = 100\text{ A}/\mu\text{s}$ $V_{DD} = 60\text{ V}, T_j = 150\text{ }^\circ\text{C}$ (see Figure 20)	-	544		ns
Q_{rr}	Reverse recovery charge		-	8.2		μC
I_{RRM}	Reverse recovery current		-	30.5		A

1. Pulse width limited by safe operating area.

 2. Pulsed: pulse duration = 300 μs , duty cycle 1.5%

Electrical characteristics

STB28N65M2, STF28N65M2, STP28N65M2, STW28N65M2

2.1 Electrical characteristics (curves)

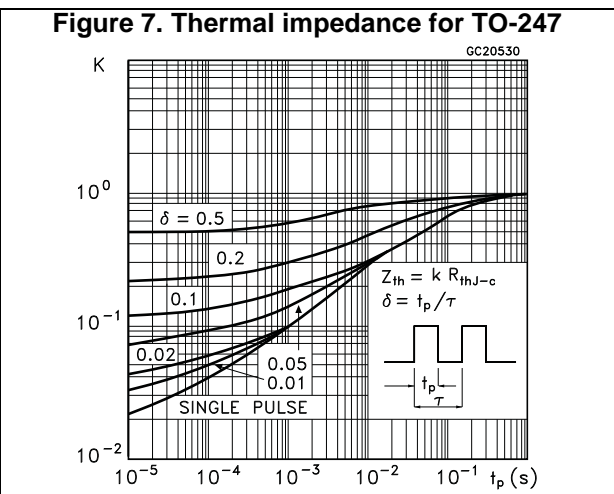
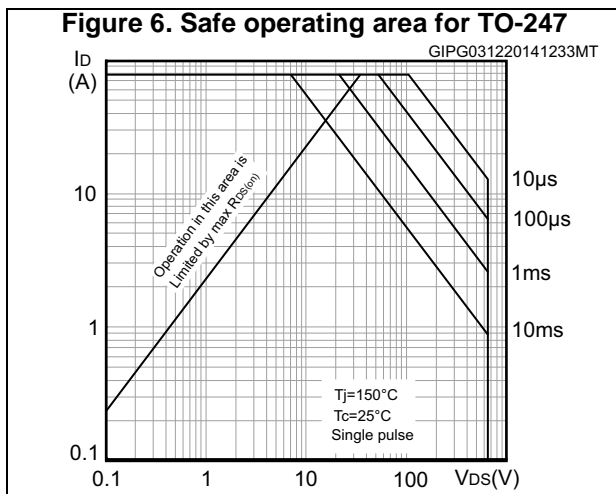
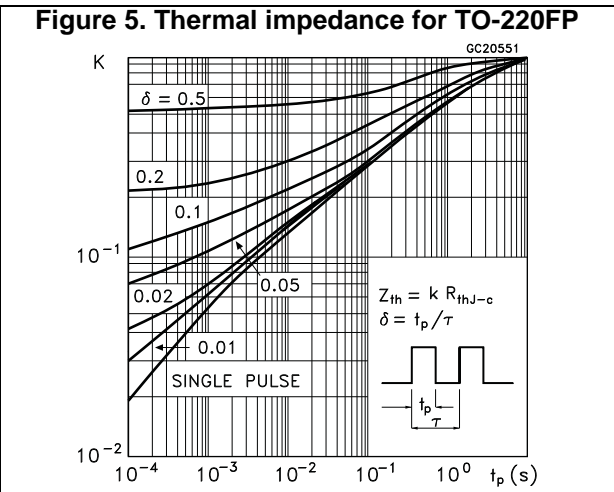
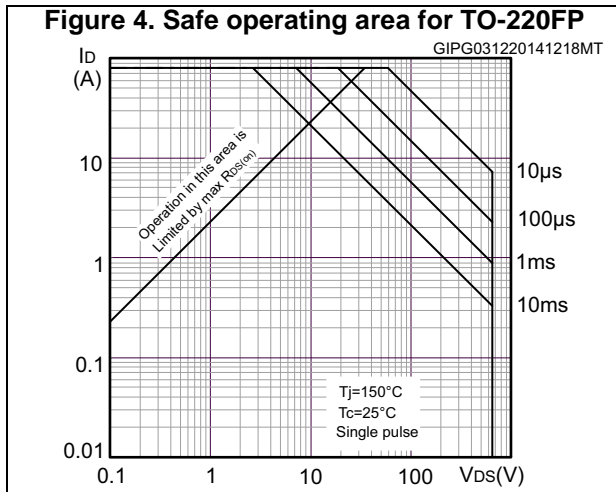
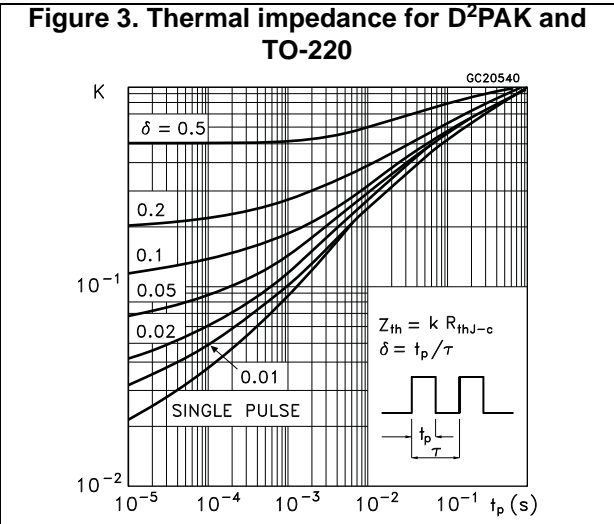
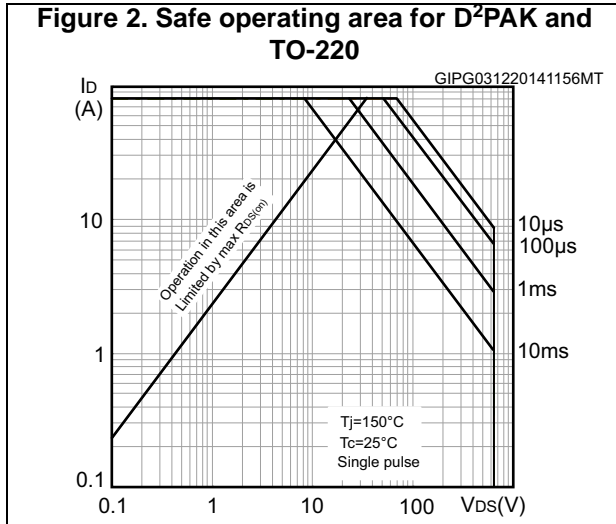

STB28N65M2, STF28N65M2, STP28N65M2, STW28N65M2

Electrical characteristics

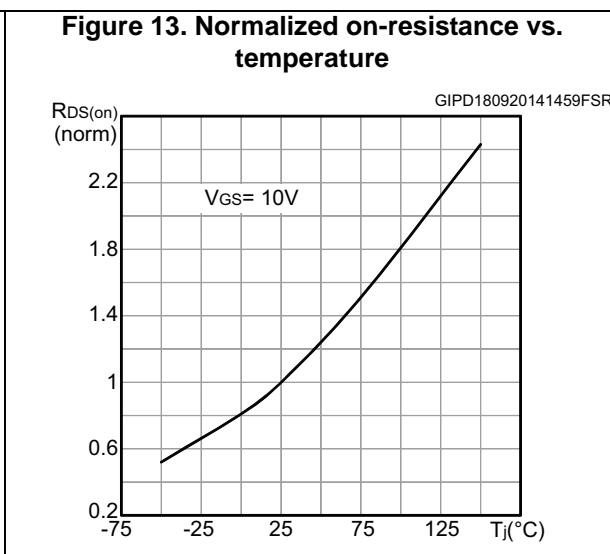
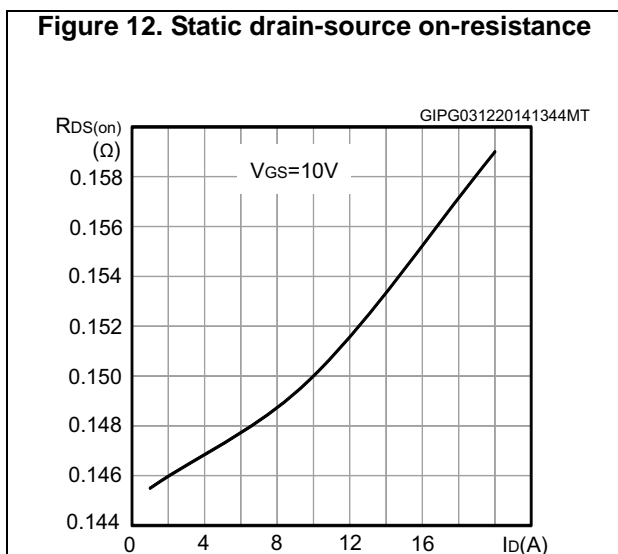
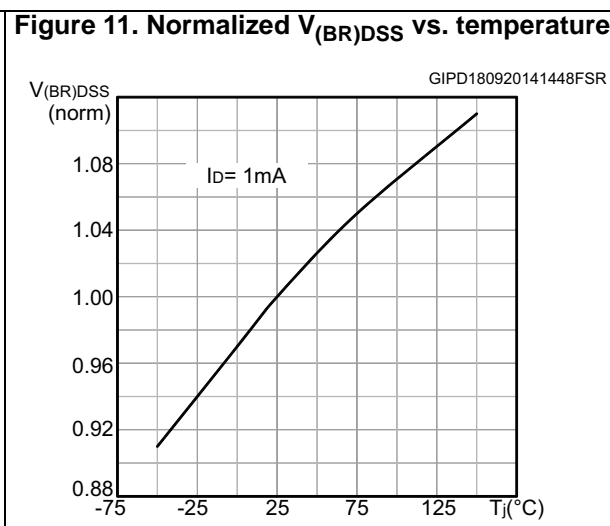
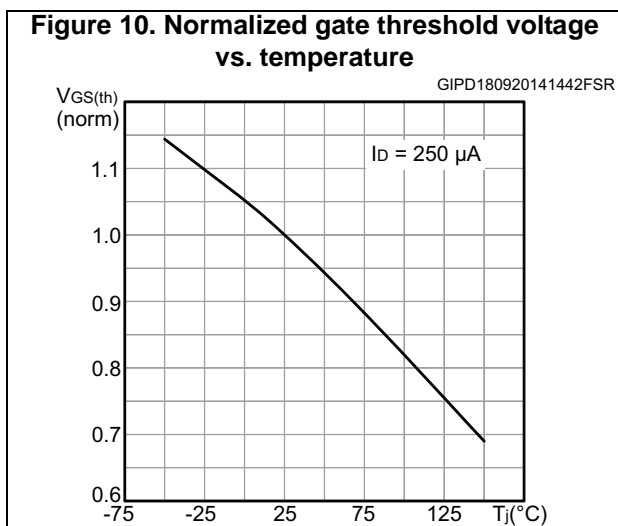
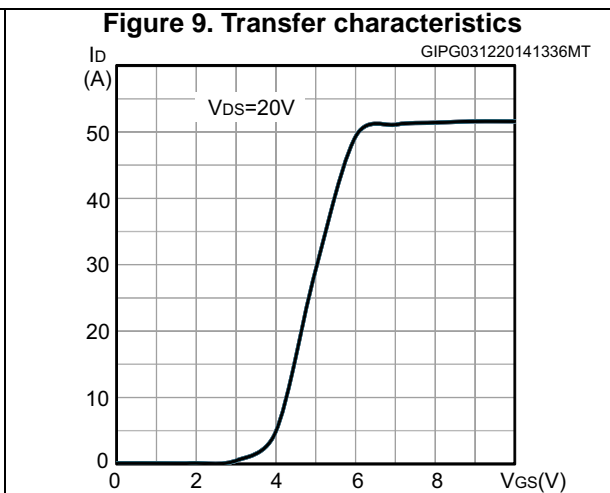
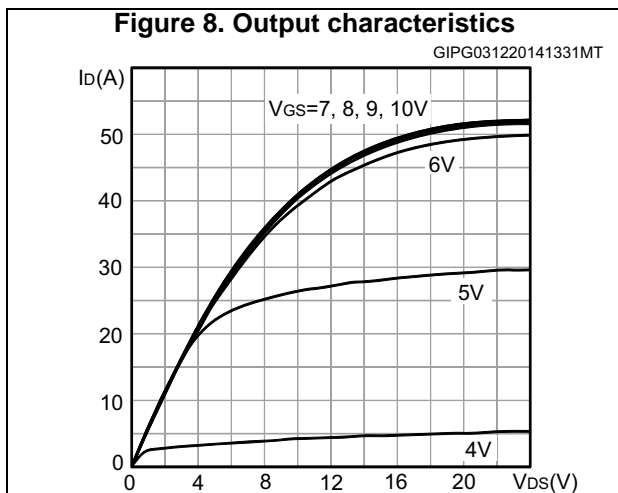

Electrical characteristics

STB28N65M2, STF28N65M2, STP28N65M2, STW28N65M2

Figure 14. Gate charge vs gate-source voltage

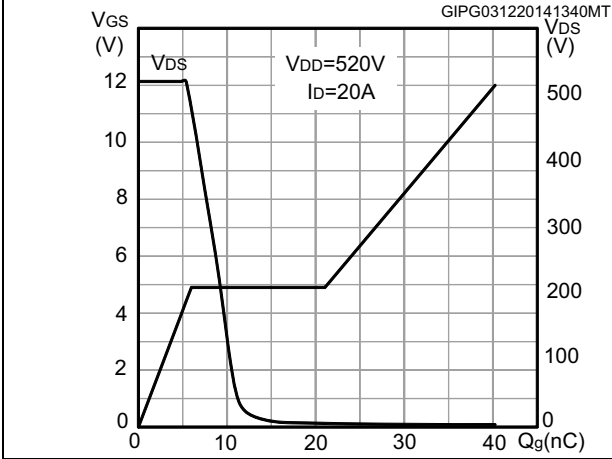

Figure 15. Capacitance variations

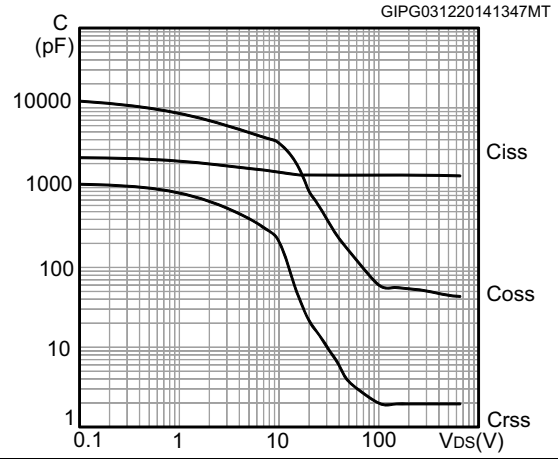

Figure 16. Output capacitance stored energy

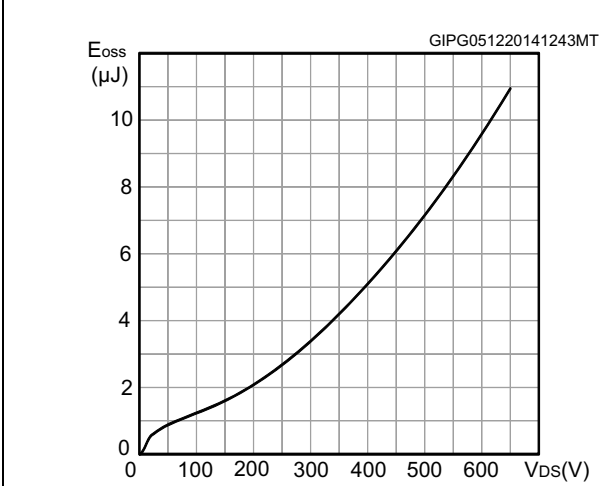
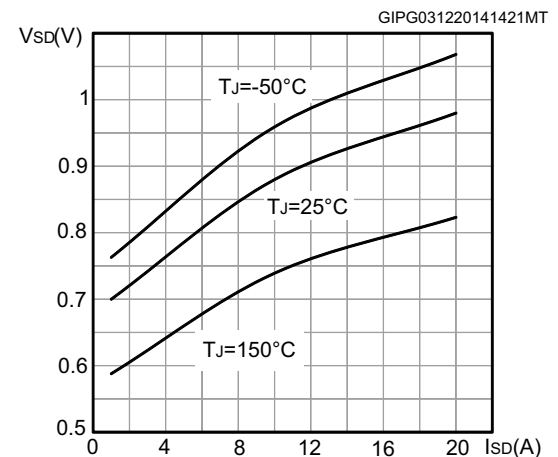

Figure 17. Source-drain diode forward characteristics



STB28N65M2, STF28N65M2, STP28N65M2, STW28N65M2

Test circuits

3 Test circuits

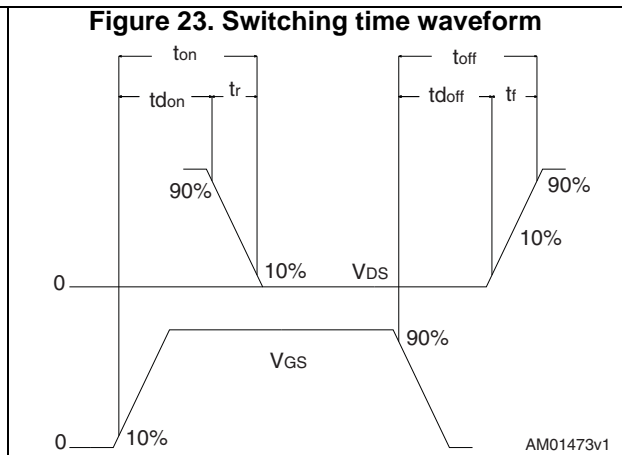
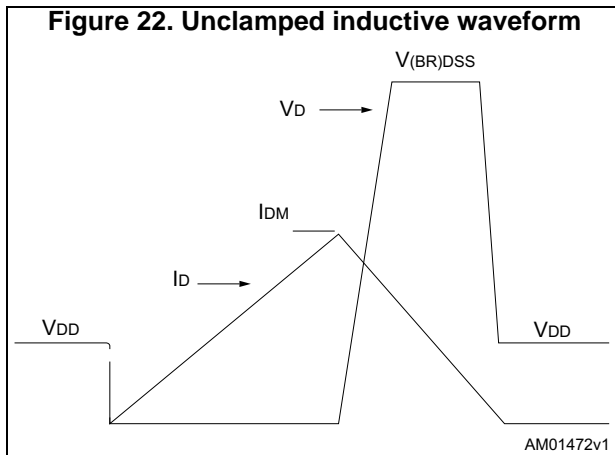
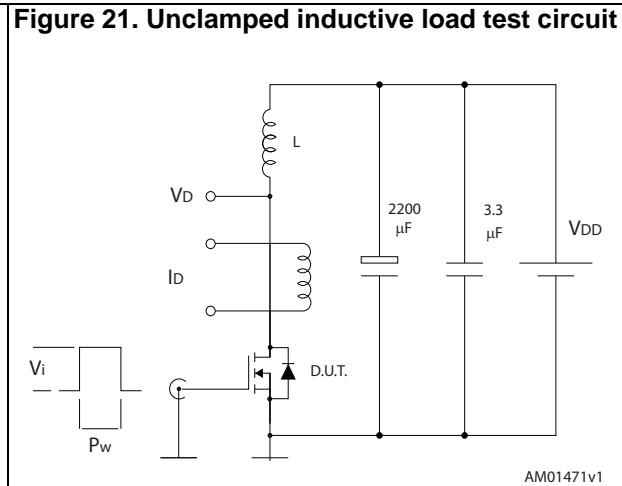
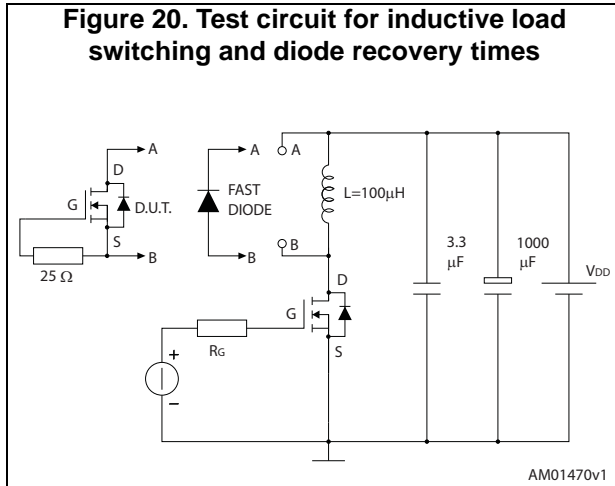
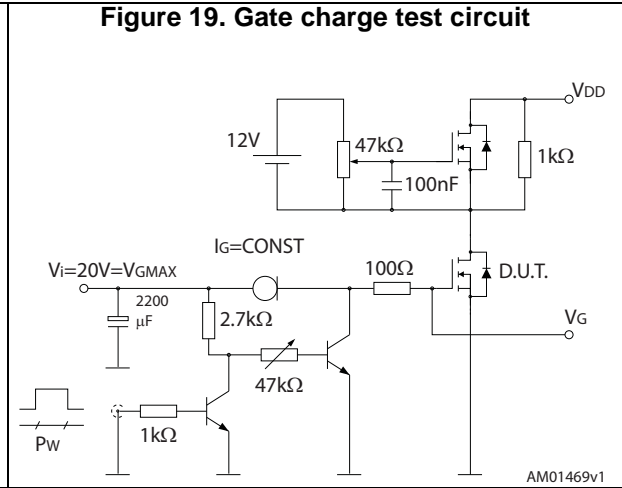
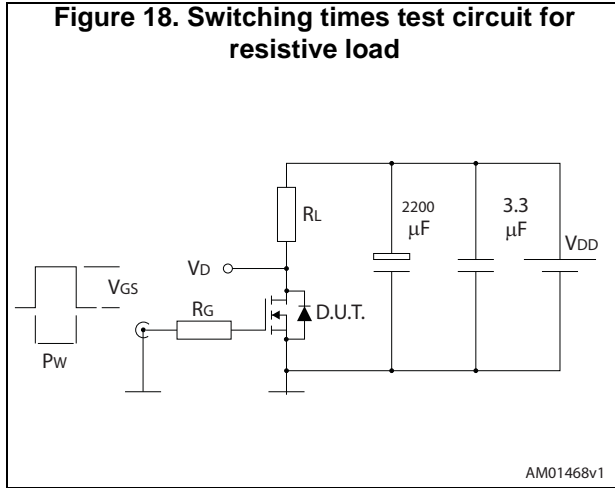

Package mechanical data

STB28N65M2, STF28N65M2, STP28N65M2, STW28N65M2

4 Package mechanical data

In order to meet environmental requirements, ST offers these devices in different grades of ECOPACK® packages, depending on their level of environmental compliance. ECOPACK® specifications, grade definitions and product status are available at: www.st.com. ECOPACK® is an ST trademark.

4.1 D²PAK, STB28N65M2

Figure 24. D²PAK drawing

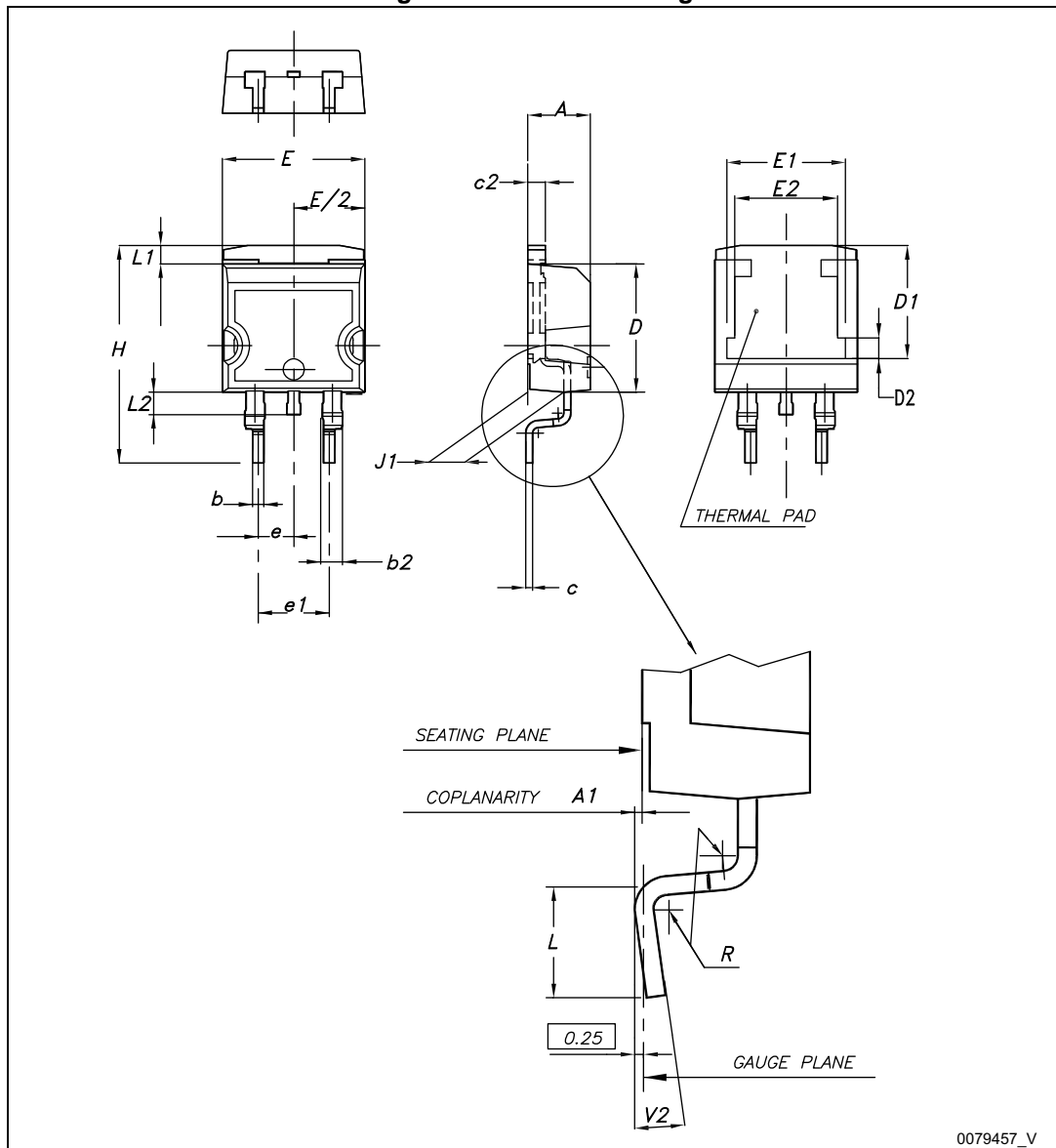

STB28N65M2, STF28N65M2, STP28N65M2, STW28N65M2

Package mechanical data

Table 9. D²PAK mechanical data

Dim.	mm		
	Min.	Typ.	Max.
A	4.40		4.60
A1	0.03		0.23
b	0.70		0.93
b2	1.14		1.70
c	0.45		0.60
c2	1.23		1.36
D	8.95		9.35
D1	7.50	7.75	8.00
D2	1.10	1.30	1.50
E	10		10.40
E1	8.50	8.70	8.90
E2	6.85	7.05	7.25
e		2.54	
e1	4.88		5.28
H	15		15.85
J1	2.49		2.69
L	2.29		2.79
L1	1.27		1.40
L2	1.30		1.75
R		0.4	
V2	0°		8°

Package mechanical data

STB28N65M2, STF28N65M2, STP28N65M2, STW28N65M2

Figure 25. D²PAK footprint (a)

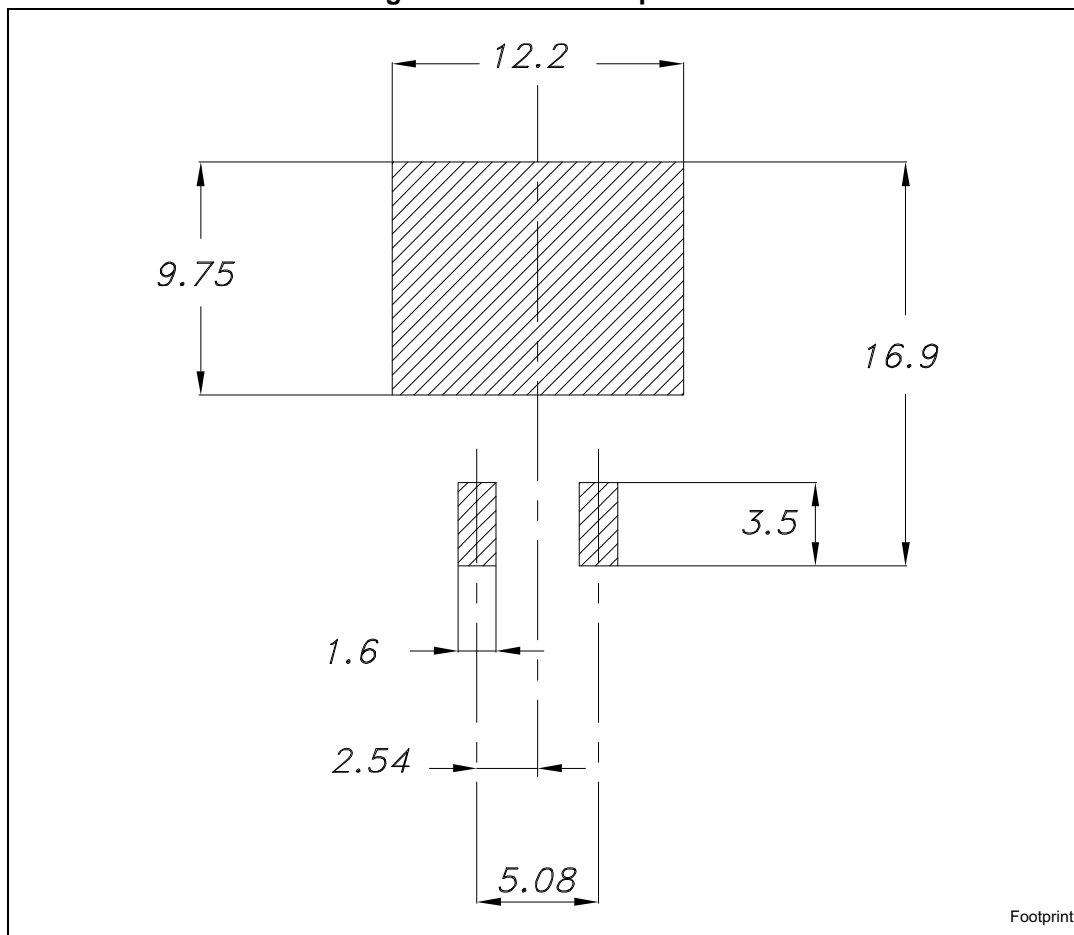

a. All dimensions are in millimeters

STB28N65M2, STF28N65M2, STP28N65M2, STW28N65M2

Package mechanical data

4.2 TO-220FP, STF28N65M2

Figure 26. TO-220FP drawing

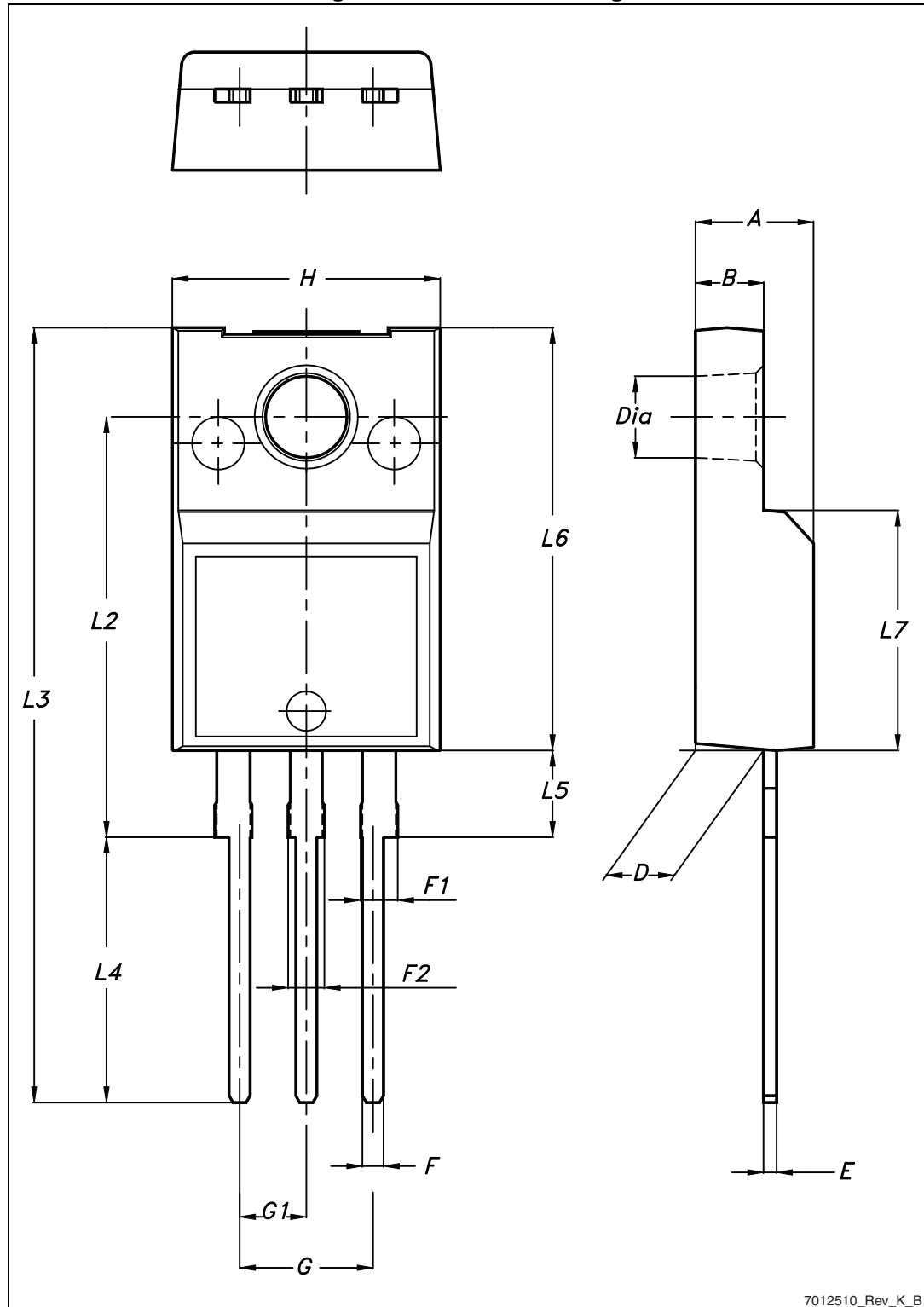

7012510_Rev_K_B

Package mechanical data

STB28N65M2, STF28N65M2, STP28N65M2, STW28N65M2

Table 10. TO-220FP mechanical data

Dim.	mm		
	Min.	Typ.	Max.
A	4.4		4.6
B	2.5		2.7
D	2.5		2.75
E	0.45		0.7
F	0.75		1
F1	1.15		1.70
F2	1.15		1.70
G	4.95		5.2
G1	2.4		2.7
H	10		10.4
L2		16	
L3	28.6		30.6
L4	9.8		10.6
L5	2.9		3.6
L6	15.9		16.4
L7	9		9.3
Ø	3		3.2

STB28N65M2, STF28N65M2, STP28N65M2, STW28N65M2

Package mechanical data

4.3 TO-220, STP28N65M2

Figure 27. TO-220 type A drawing

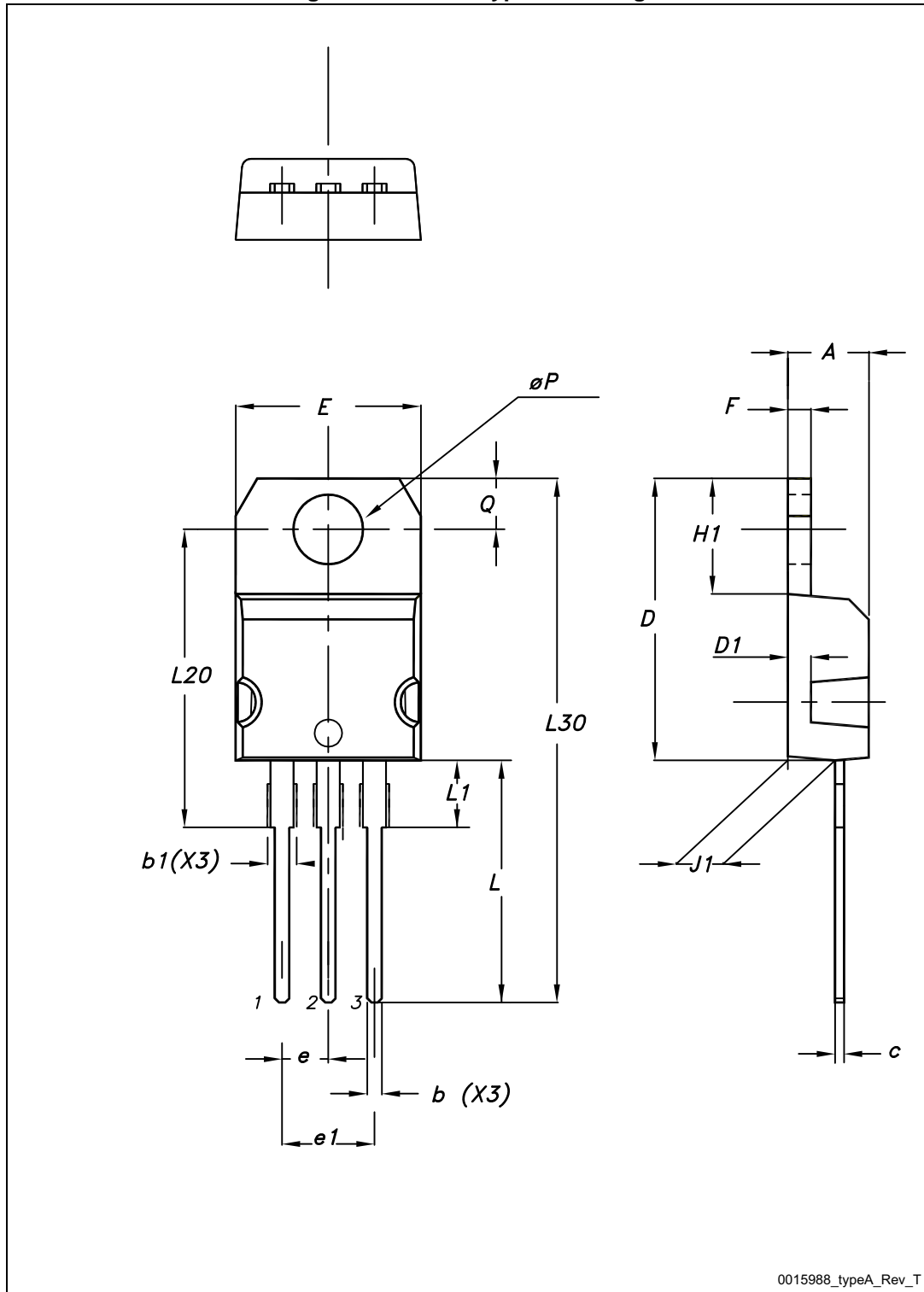

Package mechanical data

STB28N65M2, STF28N65M2, STP28N65M2, STW28N65M2

Table 11. TO-220 type A mechanical data

Dim.	mm		
	Min.	Typ.	Max.
A	4.40		4.60
b	0.61		0.88
b1	1.14		1.70
c	0.48		0.70
D	15.25		15.75
D1		1.27	
E	10		10.40
e	2.40		2.70
e1	4.95		5.15
F	1.23		1.32
H1	6.20		6.60
J1	2.40		2.72
L	13		14
L1	3.50		3.93
L20		16.40	
L30		28.90	
ØP	3.75		3.85
Q	2.65		2.95

STB28N65M2, STF28N65M2, STP28N65M2, STW28N65M2

Package mechanical data

4.4 TO-247, STW28N65M2

Figure 28. TO-247 drawing

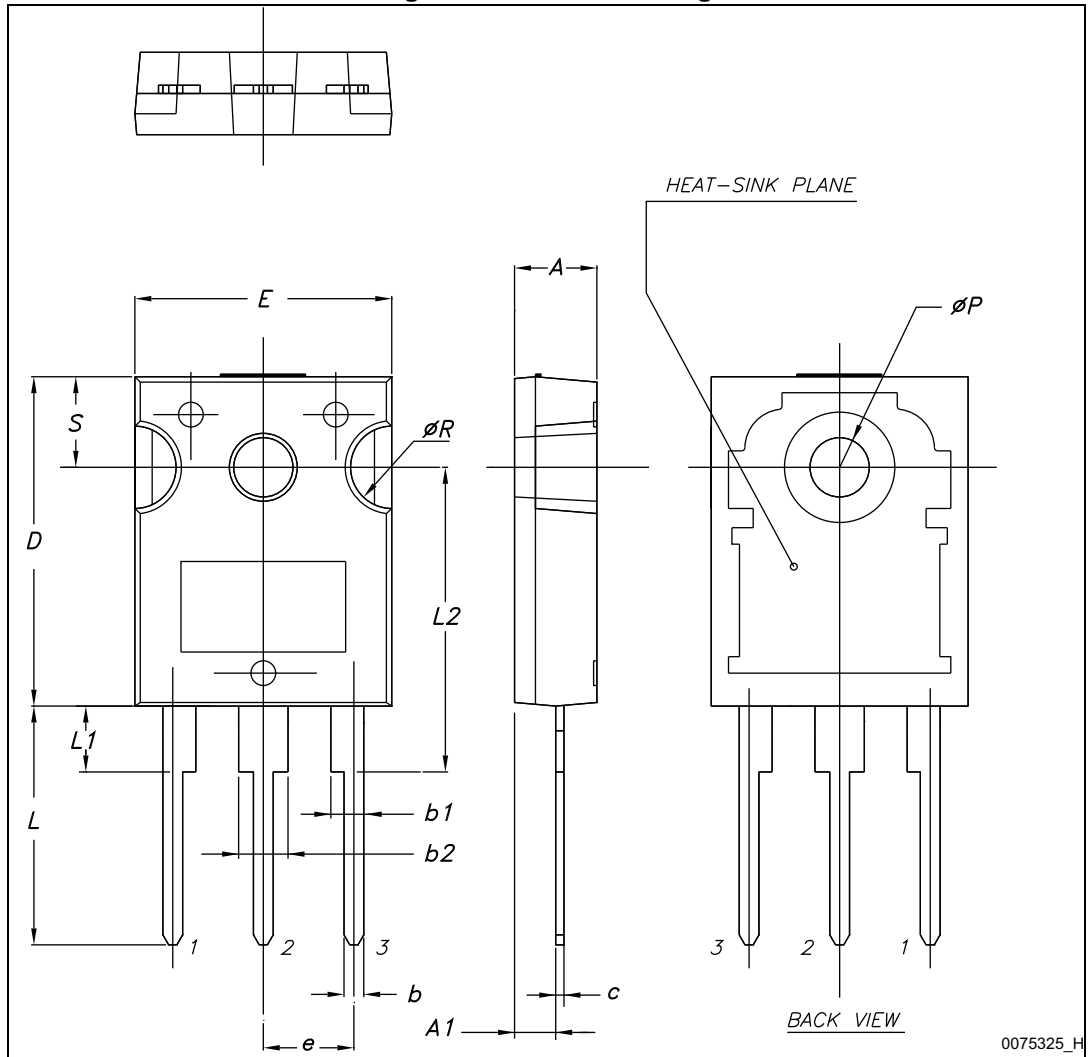

Package mechanical data

STB28N65M2, STF28N65M2, STP28N65M2, STW28N65M2

Table 12. TO-247 mechanical data

Dim.	mm.		
	Min.	Typ.	Max.
A	4.85		5.15
A1	2.20		2.60
b	1.0		1.40
b1	2.0		2.40
b2	3.0		3.40
c	0.40		0.80
D	19.85		20.15
E	15.45		15.75
e	5.30	5.45	5.60
L	14.20		14.80
L1	3.70		4.30
L2		18.50	
ØP	3.55		3.65
ØR	4.50		5.50
S	5.30	5.50	5.70

STB28N65M2, STF28N65M2, STP28N65M2, STW28N65M2

Packing mechanical data

5 Packing mechanical data

Figure 29. Tape for D²PAK

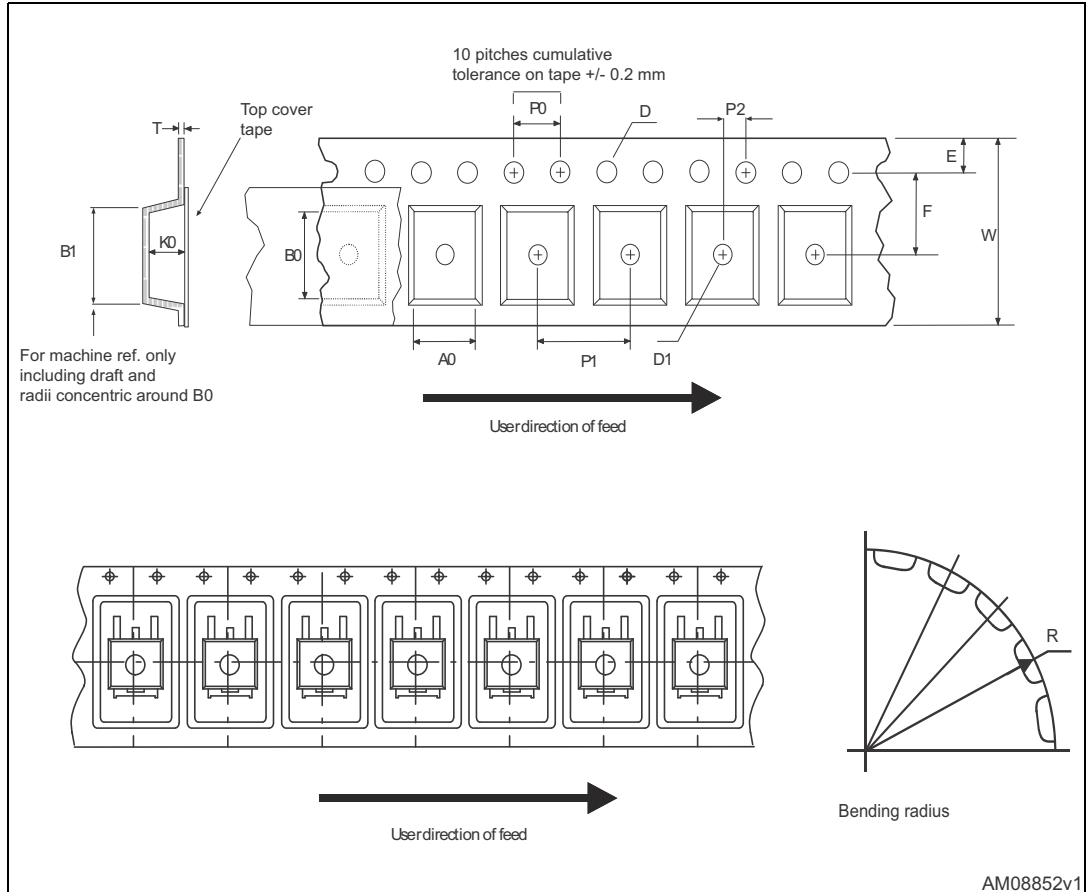

Packing mechanical data

STB28N65M2, STF28N65M2, STP28N65M2, STW28N65M2

Figure 30. Reel for D²PAK

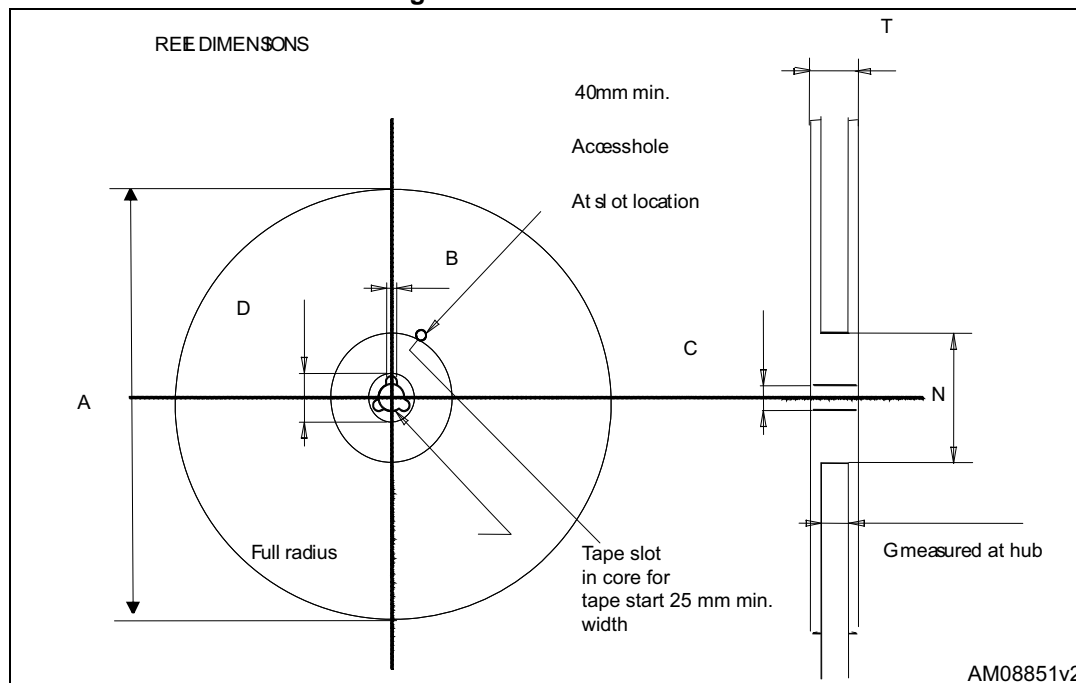

Table 13. D²PAK tape and reel mechanical data

Tape			Reel		
Dim.	mm		Dim.	mm	
	Min.	Max.		Min.	Max.
A0	10.5	10.7	A		330
B0	15.7	15.9	B	1.5	
D	1.5	1.6	C	12.8	13.2
D1	1.59	1.61	D	20.2	
E	1.65	1.85	G	24.4	26.4
F	11.4	11.6	N	100	
K0	4.8	5.0	T		30.4
P0	3.9	4.1			
P1	11.9	12.1	Base qty		1000
P2	1.9	2.1	Bulk qty		1000
R	50				
T	0.25	0.35			
W	23.7	24.3			

6 Revision history

Table 14. Document revision history

Date	Revision	Changes
09-Dec-2014	1	First release.

STB28N65M2, STF28N65M2, STP28N65M2, STW28N65M2

IMPORTANT NOTICE – PLEASE READ CAREFULLY

STMicroelectronics NV and its subsidiaries (“ST”) reserve the right to make changes, corrections, enhancements, modifications, and improvements to ST products and/or to this document at any time without notice. Purchasers should obtain the latest relevant information on ST products before placing orders. ST products are sold pursuant to ST’s terms and conditions of sale in place at the time of order acknowledgement.

Purchasers are solely responsible for the choice, selection, and use of ST products and ST assumes no liability for application assistance or the design of Purchasers’ products.

No license, express or implied, to any intellectual property right is granted by ST herein.

Resale of ST products with provisions different from the information set forth herein shall void any warranty granted by ST for such product.

ST and the ST logo are trademarks of ST. All other product or service names are the property of their respective owners.

Information in this document supersedes and replaces information previously supplied in any prior versions of this document.

© 2014 STMicroelectronics – All rights reserved