

Excellent Integrated System Limited

Stocking Distributor

Click to view price, real time Inventory, Delivery & Lifecycle Information:

[Molex Connector Corporation](#)
[0397130012](#)

For any questions, you can email us directly:
sales@integrated-circuit.com

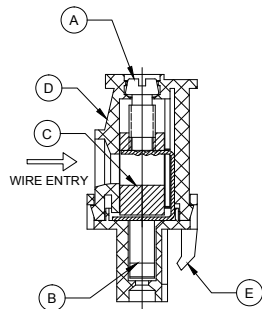
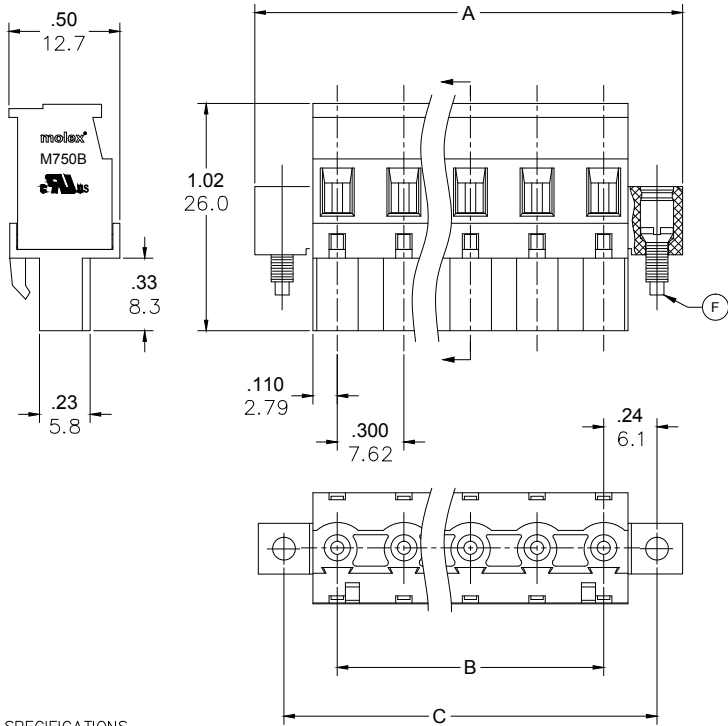

CONTACT FACTORY FOR OPTIONAL COLORS

M750B-10-5-XX-3
 COLOR
 POLES
 PITCH
 STYLE
 SERIES

SPECIFICATIONS

1. MATERIAL:

- A. SCREW: STEEL, M3, ZINC PLATED
- B. CONTACT : BRONZE, TIN PLATED
- C. CAGE: BRASS, NICKEL PLATED
- D. BODY : PA66, UL94 V-0
- E. COVER: PA66, UL94 V-0
- F. MOUNTING SCREW: STEEL, M2.5, ZINC PLATED

2. WIRE SIZE: 30-12AWG

- 3. RATING: 15A AT 51-150V, 15A AT 151-300V
- 4. POWER-FREQUENCY WITHSTAND: AC 2500V/1MIN.
- 5. INSULATION RESISTANCE: DC500V 500MΩ OR ABOVE
- 6. RATED IMPULSE VOLTAGE: 4000V/PLUS AND MINUS 5 TIMES EACH
- 7. WIRE STRIP LENGTH: .28 IN. (7.0mm)
- 8. SCREW TORQUE: 5.0 IN LBS. (0.56 N.M)
- 9. OPERATING TEMPERATURE: -40°C TO +105°C
- 10. DIMS SHOWN ARE FOR REFERENCE ONLY

PART NUMBER DATA							
CIRCUITS	PART NUMBER	ENGINEERING NUMBER	COLOR	A IN mm	B IN mm	C IN mm	
2	397130002	M750B-10-5-02-3	GREEN	1.01	25.7	.300 7.62	.78 19.8
3	397130003	M750B-10-5-03-3	GREEN	1.31	33.3	.600 15.24	1.08 27.4
4	397130004	M750B-10-5-04-3	GREEN	1.61	40.9	.900 22.86	1.38 35.1
5	397130005	M750B-10-5-05-3	GREEN	1.91	48.5	1.200 30.48	1.68 42.7
6	397130006	M750B-10-5-06-3	GREEN	2.21	56.2	1.500 38.10	1.98 50.3
7	397130007	M750B-10-5-07-3	GREEN	2.51	63.8	1.800 45.72	2.28 57.9
8	397130008	M750B-10-5-08-3	GREEN	2.81	71.4	2.100 53.34	2.58 65.5
9	397130009	M750B-10-5-09-3	GREEN	3.11	79.0	2.400 60.96	2.88 73.2
10	397130010	M750B-10-5-10-3	GREEN	3.41	86.6	2.700 68.58	3.18 80.8
11	397130011	M750B-10-5-11-3	GREEN	3.71	94.3	3.000 76.20	3.48 88.4
12	397130012	M750B-10-5-12-3	GREEN	4.01	101.9	3.300 83.82	3.78 96.0

REF. LAST 2 DIGITS OF PART NUMBER EQUALS CIRCUIT COUNT

RELEASED EC NO: JPC2014-1533 DRWN: RSTONE 2014/03/20 CHKD: G. FARNS APPR: JFMURPHY 2014/10/16 REV A	QUALITY SYMBOL ▽=0 ▽=0	GENERAL TOLERANCES (UNLESS SPECIFIED)		DIMENSION STYLE MM ONLY		SCALE ---	DESIGN UNITS METRIC	THIRD ANGLE PROJECTION	
		mm	INCH	DRAWN BY RSTONE	DATE 2014/02/27	TITLE PLUGGABLE TERMINAL BLOCK 7.62MM (.300) PITCH VERT REAR FACING-MTG ENDS			
		4 PLACES ±	±	CHECKED BY G. FARNS	DATE ---	MOLEX INCORPORATED			
		3 PLACES ±	±.005	APPROVED BY JFMURPHY		DATE 2014/10/16	DOCUMENT NO. SD-39713-001		
2 PLACES ±0.13	±.01	MATERIAL NO.		SEE CHART		SHEET NO. 1 OF 1			
1 PLACE ±0.3	±	ANGULAR ±°		DRAFT WHERE APPLICABLE MUST REMAIN WITHIN DIMENSIONS		THIS DRAWING CONTAINS INFORMATION THAT IS PROPRIETARY TO MOLEX INCORPORATED AND SHOULD NOT BE USED WITHOUT WRITTEN PERMISSION			