

## Excellent Integrated System Limited

Stocking Distributor

Click to view price, real time Inventory, Delivery & Lifecycle Information:

[Molex Connector Corporation](#)  
[0669024700](#)

For any questions, you can email us directly:

[sales@integrated-circuit.com](mailto:sales@integrated-circuit.com)

Soldering Fixture for Imperium Outer Ferrule

**Soldering Fixture  
for Imperium  
Outer Ferrule**



**Application Tooling  
Specification Sheet**

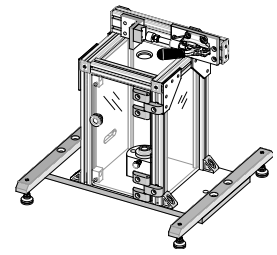

**Order No. 66902-4700**

**FEATURES**

- This fixture assists in locating the outer ferrule of the Imperium™ cable assembly for reflow soldering.
- Protects operator from the heat generated by the induction soldering process.
- Intended for use with the RDO Induction power supply, model HFI-3 (not included with this fixture)



**SCOPE**

Products: Imperium™ Inner Ferrules for 1/0 and 1AWG cables

Ferrule Part No.	Cable Size
31570-4102	1/0
31570-4103	1 AWG

**Description:**

The principal parts of the fixture are shown below. See Figure 1.

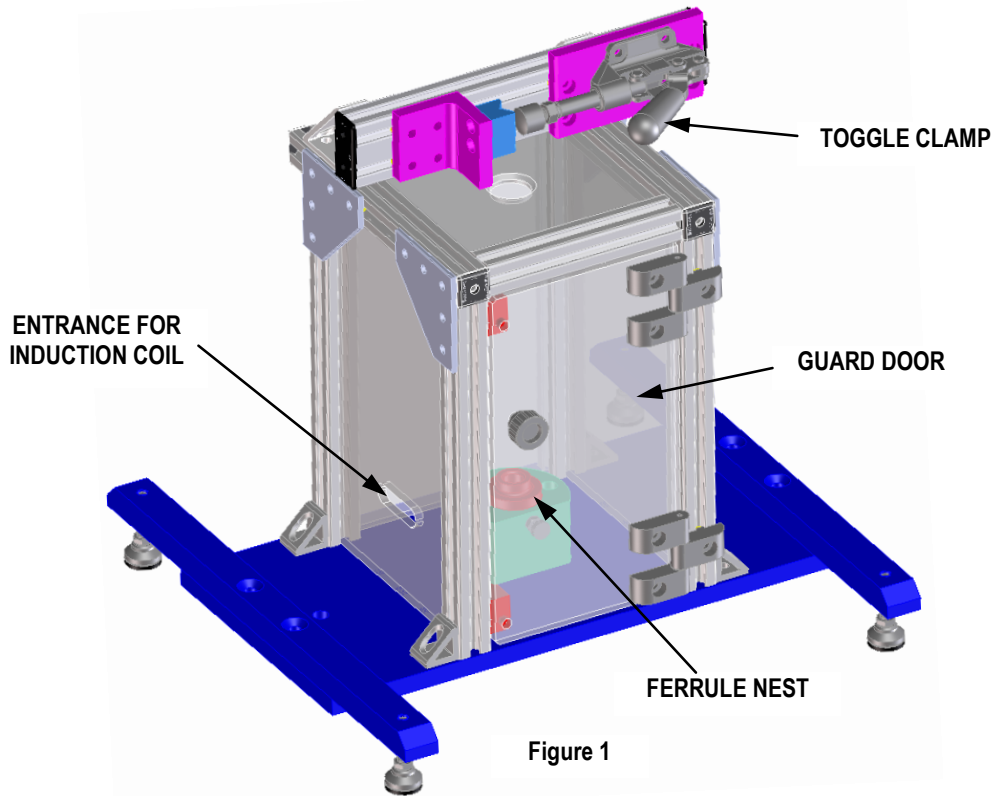

Figure 1

Soldering Fixture for Imperium Outer Ferrule

**Operation**

1. Prepare the cable end per section 9.0 of Application Specification AS-171467-001.
2. To protect the cable end, the inner insulation slug should remain on the cable.
3. Open the toggle clamp on the top of the fixture guard.
4. Put the cable end through the hole in the top of the guard.

**NOTE:** The cable seal will fit through the hole in the guard but the seal cover will not.

5. Let the Outer Ferrule rest on the ferrule nest. Close the toggle clamp to keep the cable in place. See Figure 2.
6. Cycle the induction soldering machine to reflow the solder paste inside the ferrule.
7. Open the toggle clamp and pull the cable out of the fixture.

The guard door should only be opened to service the ferrule nest. For operator safety, it must remain closed during operation

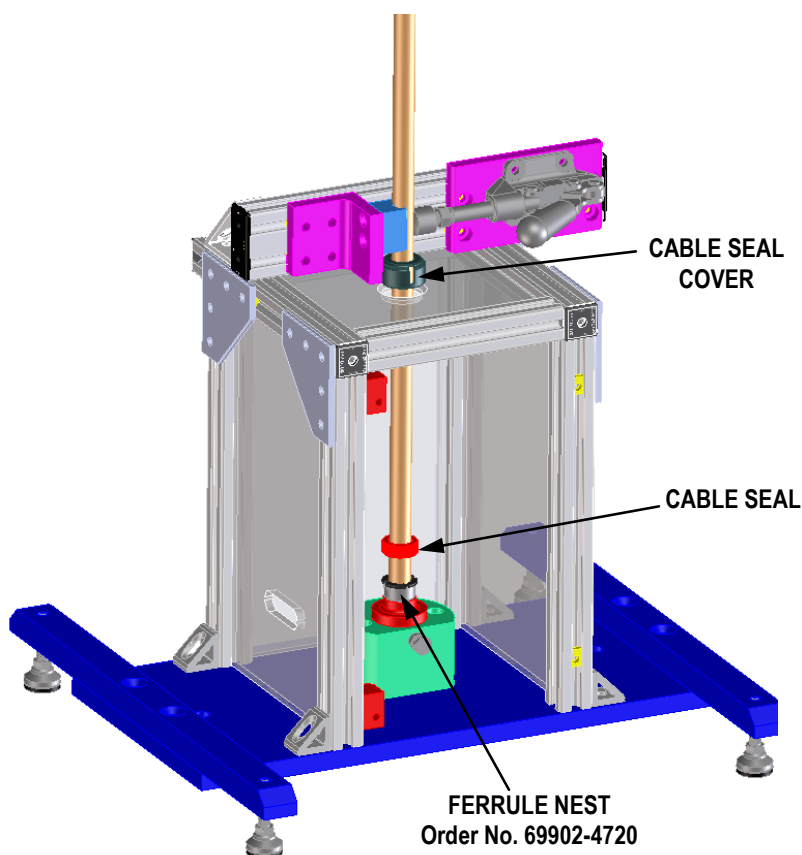

(GUARD DOOR AND INDUCTION HEATING COIL NOT SHOWN FOR CLARITY)  
Figure 2

Visit our Web site at <http://www.molex.com>