

LEX CONNECTOR

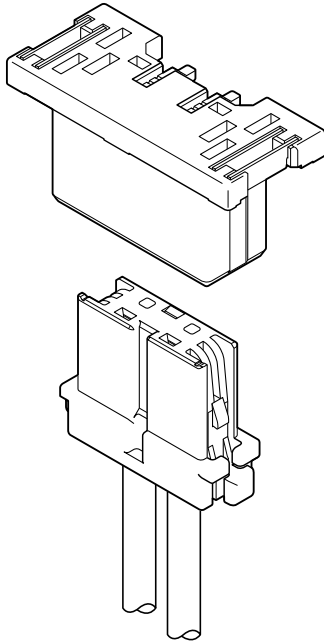

2.5mm pitch/For LED Lamp/Disconnectable Crimp style connectors



Considering about luminescence property of LED package, this LEX connector is designed as low profile bottom type connector for LED lighting equipment, and achieves the space saving at the connector mounting side.

In consideration of connector mating operation, secure lock and mechanism for preventing wrong insertion are provided. With the assumption that the load may be applied to the soldering part when mating the connector, the strength of soldering part after mounting the connector on PCB has been largely improved.

- **Low profile and space saving design**
Mounting height at connector mounting side: 1.2mm
- **Secure locking mechanism**
- **Mechanism for preventing wrong insertion**
- **Halogen-free and RoHS compliant**

Specifications

- Current rating: 3 A AC, DC (AWG #22)
- Voltage rating: 300 V AC, DC
- Temperature range: -55°C to +105°C
(including temperature rise in applying electrical current)
- Contact resistance: Initial value/ 10 mΩ max.
After environmental tests/ 20 mΩ max.
- Insulation resistance: 1,000 MΩ min.
- Withstanding voltage: 1,700 VAC/minute
- Applicable wire: Conductor size/ AWG #30 to #22
Insulation O.D./ 0.7 to 1.3 mm

- * Refer to "General Instruction and Notice when using Terminals and Connectors" at the end of this catalog.
- * Contact JST for details.
- * Compliant with RoHS.

Standards

Recognized E60389

Certified LR20812

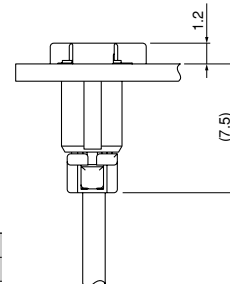
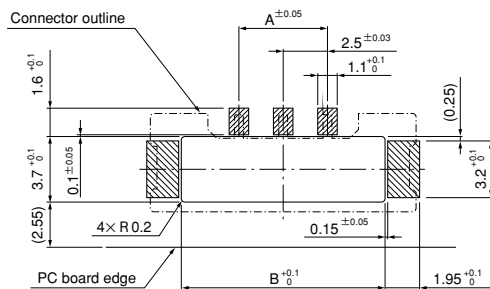

Circuits	Dimensions (mm)	
	A	B
2	—	9.0
4	7.5	14.0

Note: 1. The above figure is the figure viewed from the connector mounting side.
2. Tolerances are non-cumulative: ±0.05mm for all centers.
The dimensions above should serve as a guideline. Contact JST for details.

LEX CONNECTOR

Contact

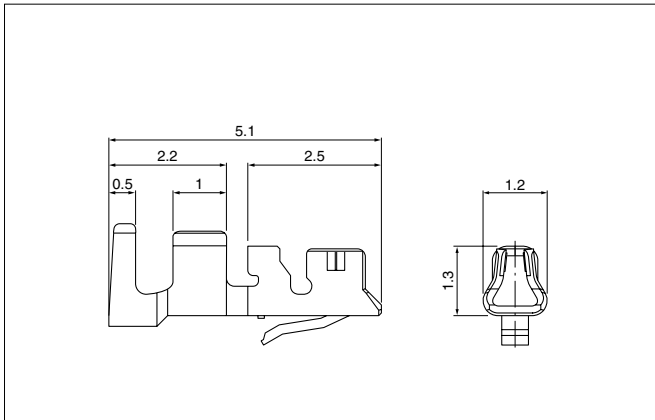

Model No.	Applicable wire			Q'ty / reel
	mm ²	AWG#	Insulation O.D. (mm)	
SSFH-001T-P0.5	0.13~0.33	26~22	0.95~1.3	15,000
SSFH-002T-P0.5	0.05~0.13	30~26	0.7~1.25	15,000

Material and Finish

Copper alloy, tin-plated (reflow treatment)

RoHS compliance

Contact	Crimping machine	Applicator		
		Crimp applicator	Dies	Crimp applicator with dies
SSFH-001T-P0.5	AP-K2N	MKS-L	MK/SSFH-001-05	APLMK SSFH001-05
		—	—	—
SSFH-002T-P0.5	AP-K2N	MKS-L	MK/SSFH-002-05	APLMK SSFH002-05
		—	—	—

Housing

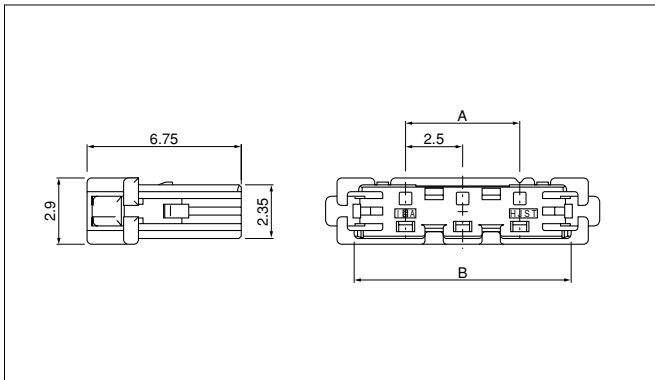

Circuits	Model No.	Dimensions (mm)		Q'ty / bag
		A	B	
2	LEXR-02V-S(HF)	—	7.0	2,000
4	LEXR-04V-S(HF)	7.5	12.0	1,000

Material

Glass-filled PA 66, UL94V-0, natural

RoHS compliance

Shrouded header

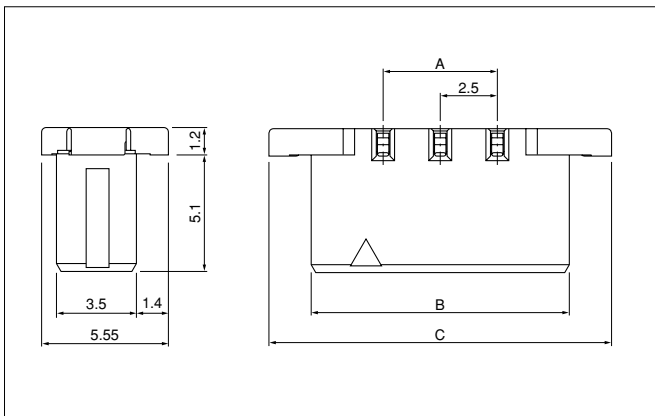

Circuits	Model No.	Dimensions (mm)			Q'ty / reel
		A	B	C	
2	EM02B-LEXSS-TF(HF)	—	8.8	12.5	1,600
4	EM04B-LEXSS-TF(HF)	7.5	13.8	17.5	1,600

Material and Finish

Press pin: Copper alloy, copper-undercoated, tin-plated (reflow treatment)

Housing: PA 9T, UL94V-0, natural

Solder tab: Copper alloy, copper-undercoated, tin-plated (reflow treatment)

RoHS compliance

Note: The products listed above are supplied on embossed-tape.