

Excellent Integrated System Limited

Stocking Distributor

Click to view price, real time Inventory, Delivery & Lifecycle Information:

[Molex Connector Corporation](#)
[0191641141](#)

For any questions, you can email us directly:

sales@integrated-circuit.com

10	9	8	7	6	5	4	3	2	1	
MATERIAL NUMBER	ENGINEERING NUMBER	MATERIAL NUMBER ON TAPE	ENGINEERING NUMBER ON TAPE	STUD SIZE	HOLE "S" ± 0.005 ± 0.03	"D" MAX	"H" ± 0.10 ± 0.25	"L" MAX	"T" REF	ID MIN
191640085	SA-221-06	191641141	SA-221-06T	#6	$\varnothing.146/3.71$	$\varnothing.32/8.1$.534/13.56	1.46/37.1	.028/0.71	.064/1.63
191640086	SA-221-08	191640419	SA-221-08T	#8	$\varnothing.173/4.39$	$\varnothing.32/8.1$.534/13.56	1.46/37.1	.028/0.71	.064/1.63
191640003	SA-221-10	191640306	SA-221-10T	#10	$\varnothing.198/5.03$	$\varnothing.32/8.1$.534/13.56	1.46/37.1	.028/0.71	.064/1.63
191640004	SA-222-14	191640844	SA-222-14T	1/4	$\varnothing.265/6.73$	$\varnothing.48/12.2$.340/8.65	1.66/42.2	.028/0.71	.064/1.63
191640435	SA-222-56	191641148	SA-222-56T	5/16	$\varnothing.328/8.33$	$\varnothing.48/12.2$.340/8.65	1.66/42.2	.028/0.71	.064/1.63
191640005	SA-226-38	191640845	SA-226-38T	3/8	$\varnothing.390/9.91$	$\varnothing.54/13.7$.328/8.33	1.95/49.5	.032/0.81	.055/1.40

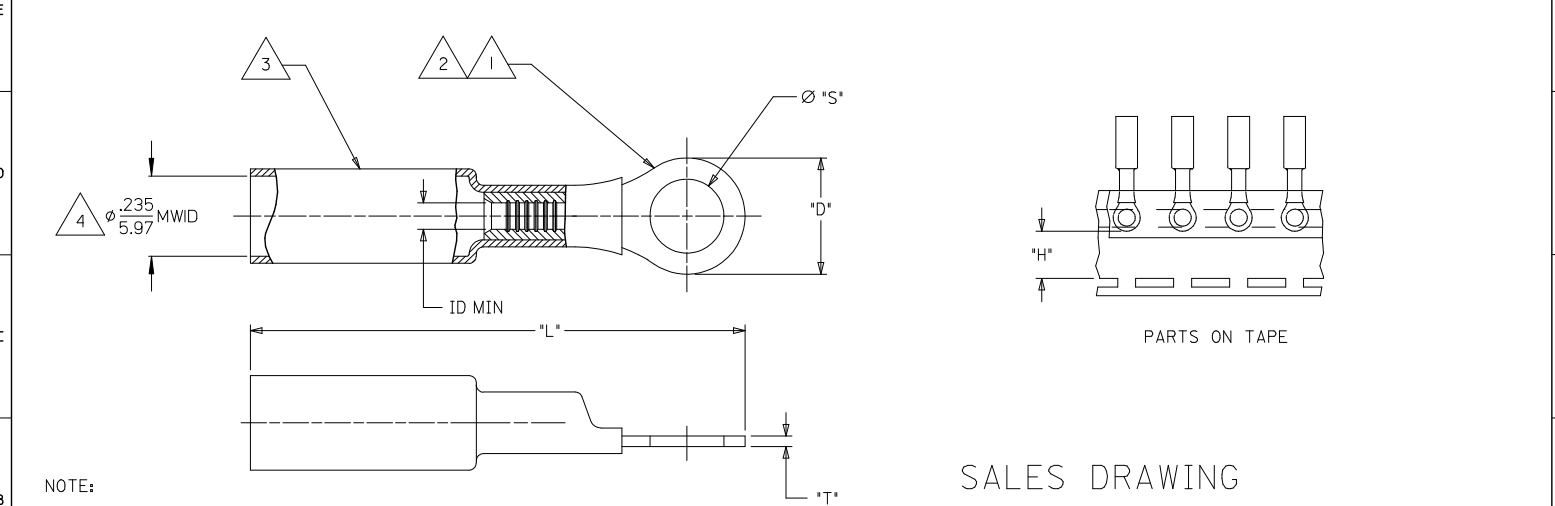

NOTE:

- 1. TERMINAL MATERIAL: COPPER ALLOY
- 2. FINISH: ELECTRO TIN PLATE.
- 3. INSULATION MATERIAL: HEAT SHRINKABLE TUBING WITH HOTMELT ADHESIVE INNER LINER. COLOR: RED.
- 4. MWID = MAXIMUM WIRE INSULATION DIAMETER.
- 5. PARTS ARE ROHS COMPLIANT.

SALES DRAWING

ADD MAT'L NUMBER EC NO: IPG2015-2076 DRAWN BY: JAS01 2015/06/03 CHKD: MACNEL 2015/06/03 APPR: MACNEL 2015/06/16 REV: D1	QUALITY SYMBOLS ▽=0 ▽=0	GENERAL TOLERANCES (UNLESS SPECIFIED)		DIMENSION STYLE IN/MM		SCALE ---	DESIGN UNITS INCH	THIRD ANGLE PROJECTION	
		4 PLACES ± --- ± ---	3 PLACES ± 0.13 ± .005	2 PLACES ± 0.25 ± .010	1 PLACE ± --- ± ---	ANGULAR ± ---°	DRAWN BY: BENDERLE DATE: 2005/5/14	CHECKED BY: HBEITZEL DATE: 2005/5/14	TITLE: RING TONGUE TERMINAL PERMA-SEAL NIAC 22-18 AWG
		DRAFT WHERE APPLICABLE MUST REMAIN WITHIN DIMENSIONS		APPROVED BY: RDEROSS DATE: 2005/5/14	MATERIAL NO. SEE CHART	DOCUMENT NO. SD-19164-006		MOLEX INCORPORATED	SHEET NO. 1 OF 1
		THIS DRAWING CONTAINS INFORMATION THAT IS PROPRIETARY TO MOLEX INCORPORATED AND SHOULD NOT BE USED WITHOUT WRITTEN PERMISSION							