

Excellent Integrated System Limited

Stocking Distributor

Click to view price, real time Inventory, Delivery & Lifecycle Information:

[Wurth Electronics Inc](#)
[S14100037](#)

For any questions, you can email us directly:

sales@integrated-circuit.com

Spezifikation für Freigabe / specification for release

Kunde / customer :

Artikelnummer / part number : **S14100037**



Bezeichnung : **STROMKOMPENSIERTE DROSSEL WE-CMBH**
 description : **COMMON MODE CHOKE WE-CMBH**

DATUM / DATE : 2015-07-23

A Mechanische Abmessungen / dimensions:

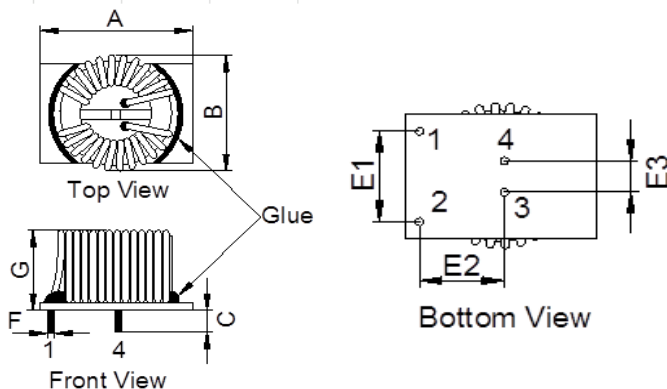

A	31,0 max.	mm
B	28,0 max.	mm
C	4,5 ± 0,5	mm
E1	15,2 ± 0,5	mm
E2	15,2 ± 0,5	mm
E3	5,1 ± 0,5	mm
F	1,32 ± 0,1	mm
G	21,0 max.	mm

B Elektrische Eigenschaften / electrical properties:

C Schaltbild / schematic:

Eigenschaften / properties	Testbedingungen / test conditions		Wert / value	Einheit / unit	tol.
Leerlauf-Induktivität / inductance	10 kHz / 50µA	L ₀	1,0	mH	±30%
DC-Widerstand / DC-resistance	@ 20°C	R _{DC}	7,5	mΩ	max.
Nennstrom / nominal current		I _{DC}	15,0	A	max.
Nennspannung / nominal voltage		U _N	250	V _{AC}	max.

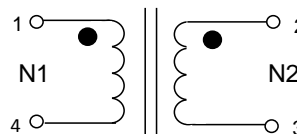

D Prüfgeräte / test equipment:

E Testbedingungen / test conditions:

WAYNE KERR WK3260B/WK3265 für/for L₀/L_N und/and RDC
HP 34401 A für/for I_N

Luftfeuchtigkeit / humidity: 33%
 Umgebungstemperatur / temperature: +25°C
 Prüfspannung / testing voltage: 1500 V, 50 Hz
 3mA , 2 sec.

F Werkstoffe & Zulassungen / material & approvals

G Eigenschaften / general specifications:

Socket / base: UL94V-0
 Draht / wire: Class F (155°C)
 Verguß / molding: UL94V-2
 Abstandhalter / spacer: UL94V-0

Klimabeständigkeit / climatic class: 40/125/21
 Betriebstemp. / operating temperature: -40°C - + 125°C
 Übertemperatur / temperature rise: < 55 K
 It is recommended that the temperature of the part does not exceed 125°C under worst case operating conditions.

Freigabe erteilt / general release:

Kunde / customer

Datum / date

Unterschrift / signature

Würth Elektronik

Geprüft / checked

Kontrolliert / approved

HasA	Version 3	15-07-23
HasA	Version 2	15-03-05
HasA	Version 1	14-04-15
Name	Änderung / modification	Datum / date

This electronic component has been designed and developed for usage in general electronic equipment. Before incorporating this component into any equipment where higher safety and reliability is especially required or if there is the possibility of direct damage or injury to human body, for example in the range of aerospace, aviation, nuclear control, submarine, transportation, (automotive control, train control, ship control), transportation signal, disaster prevention, medical, public information network etc, Würth Elektronik eiSos GmbH must be informed before the design-in stage. In addition, sufficient reliability evaluation checks for safety must be performed on every electronic component which is used in electrical circuits that require high safety and reliability functions or performance.

Spezifikation für Freigabe / specification for release

Kunde / customer :

Artikelnummer / part number : **S14100037**



Bezeichnung : **STROMKOMPENSIERTE DROSSEL WE-CMBH**
 description : **COMMON MODE CHOKE WE-CMBH**

WÜRTH ELEKTRONIK

DATUM / DATE : 2015-07-23

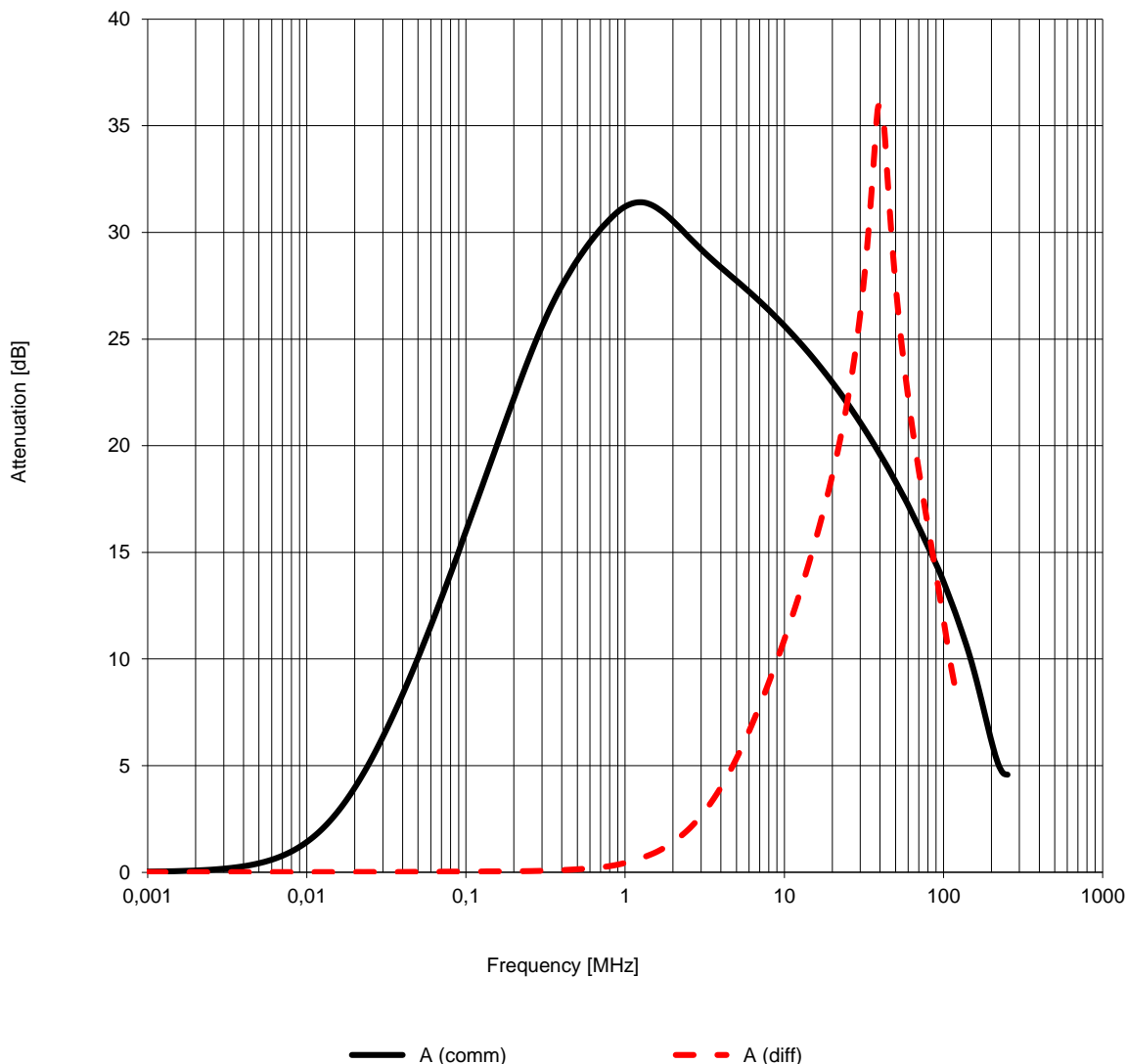

Freigabe erteilt / general release:	Kunde / customer		
Datum / date	Unterschrift / signature		
	Würth Elektronik		
	HasA	Version 3	15-07-23
	HasA	Version 2	15-03-05
	HasA	Version 1	14-04-15
Geprüft / checked	Kontrolliert / approved	Name	Änderung / modification Datum / date

This electronic component has been designed and developed for usage in general electronic equipment. Before incorporating this component into any equipment where higher safety and reliability is especially required or if there is the possibility of direct damage or injury to human body, for example in the range of aerospace, aviation, nuclear control, submarine, transportation, (automotive control, train control, ship control), transportation signal, disaster prevention, medical, public information network etc, Würth Elektronik eiSos GmbH must be informed before the design-in stage. In addition, sufficient reliability evaluation checks for safety must be performed on every electronic component which is used in electrical circuits that require high safety and reliability functions or performance.

Würth Elektronik eiSos GmbH & Co. KG