

Excellent Integrated System Limited

Stocking Distributor

Click to view price, real time Inventory, Delivery & Lifecycle Information:

[E-Switch](#)
[PS1040ARED](#)

For any questions, you can email us directly:

sales@integrated-circuit.com

SHEET 0F

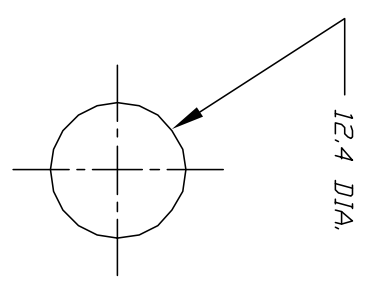
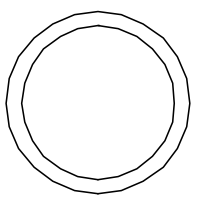

RECOMMEND PANEL LAYOUT

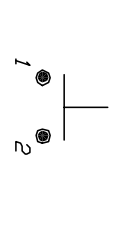
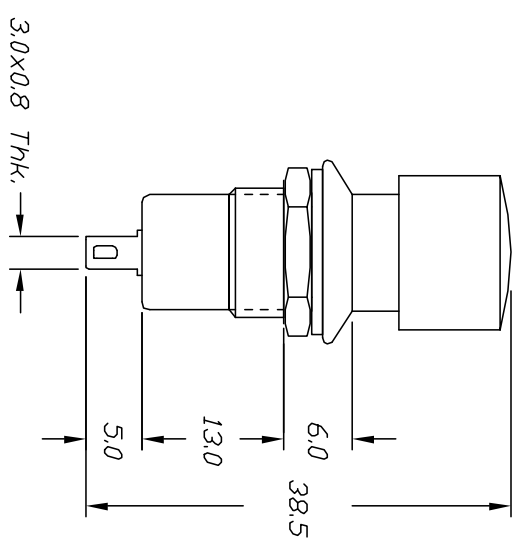
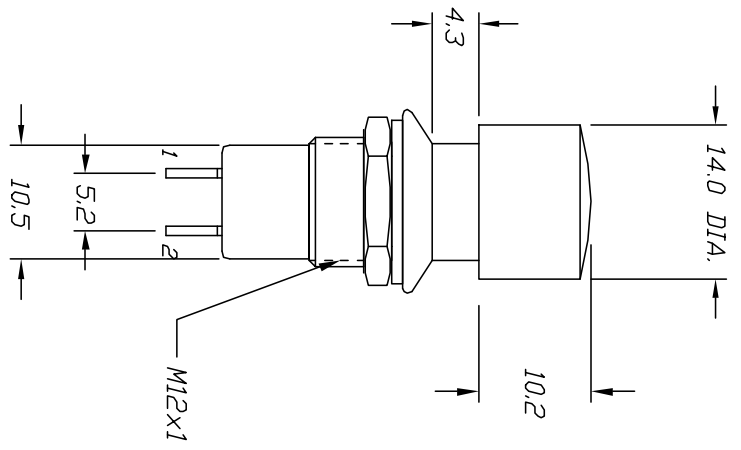

CONTACT CONFIGURATION



< >=Momentary

NOTES:

1. ALL DIMENSIONS IN MM
2. TERM. NOS. FOR REF ONLY
3. RATING: 3A 125VAC

REV.		DESCRIPTION	DATE	CHK'D
A		RELEASED FOR PRODUCTION		
E-SWITCH® PS 1040A (RED BUTTON) TITLE				
TOLERANCES				
0.0		±0.4		
0.00		±0.25		
SCALE	DATE	DR	DWG	REV
1.5:1	3/4/97	NM	F010400	A
THE INFORMATION CONTAINED IN THIS DOCUMENT IS PROPRIETARY TO E-SWITCH AND IS NOT TO BE COPIED OR TRANSMITTED				