

Excellent Integrated System Limited

Stocking Distributor

Click to view price, real time Inventory, Delivery & Lifecycle Information:

[STMicroelectronics](#)
[HCF4093BEY](#)

For any questions, you can email us directly:

sales@integrated-circuit.com



HCF4093B

QUAD 2 INPUT NAND SCHMITT TRIGGER

- SCHMITT TRIGGER ACTION ON EACH INPUT WITH NO EXTERNAL COMPONENTS
- HYSTERESIS VOLTAGE TYPICALLY 0.9V at $V_{DD} = 5V$ AND 2.3V at $V_{DD} = 10V$
- NOISE IMMUNITY GREATER THAN 50% OF V_{DD} (Typ.)
- NO LIMIT ON INPUT RISE AND FALL TIMES
- QUIESCENT CURRENT SPECIFIED UP TO 20V
- STANDARDIZED SYMMETRICAL OUTPUT CHARACTERISTICS
- 5V, 10V AND 15V PARAMETRIC RATINGS
- INPUT LEAKAGE CURRENT
 $I_l = 100nA$ (MAX) AT $V_{DD} = 18V$ $T_A = 25^\circ C$
- 100% TESTED FOR QUIESCENT CURRENT
- MEETS ALL REQUIREMENTS OF JEDEC JESD13B "STANDARD SPECIFICATIONS FOR DESCRIPTION OF B SERIES CMOS DEVICES"

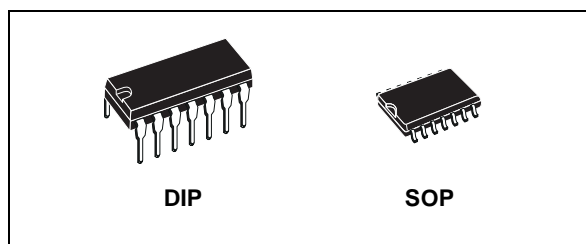

ORDER CODES

PACKAGE	TUBE	T & R
DIP	HCF4093BEY	
SOP	HCF4093BM1	HCF4093M013TR

DESCRIPTION

The HCF4093B is a monolithic integrated circuit fabricated in Metal Oxide Semiconductor technology available in DIP and SOP packages.

The HCF4093B type consists of four schmitt trigger circuits. Each circuit functions as a two input NAND gate with schmitt trigger action on both inputs. The gate switches at different points for positive and negative going signals. The difference between the positive voltage (V_P) and the negative voltage (V_N) is defined as hysteresis voltage (V_H).

PIN CONNECTION

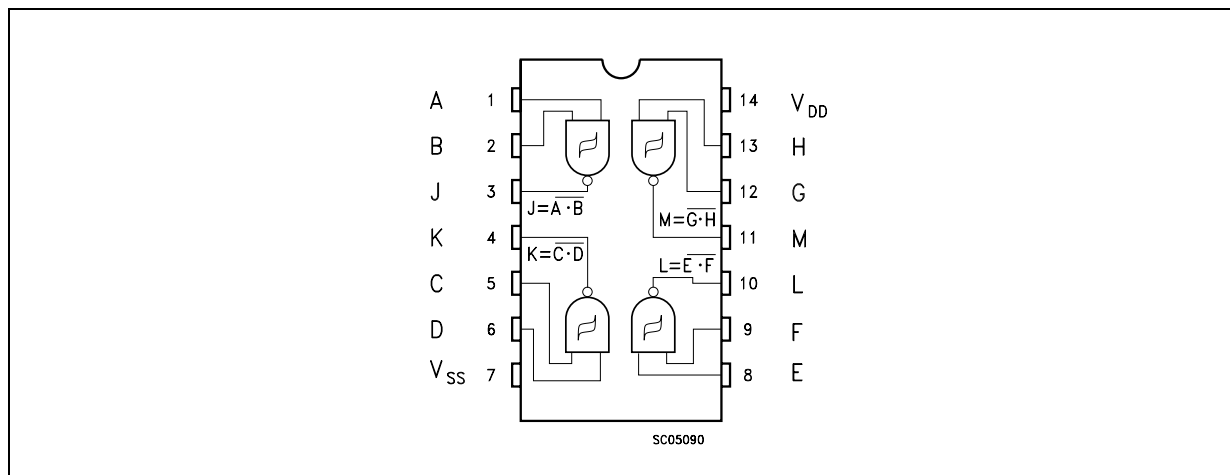

HCF4093B

INPUT EQUIVALENT CIRCUIT

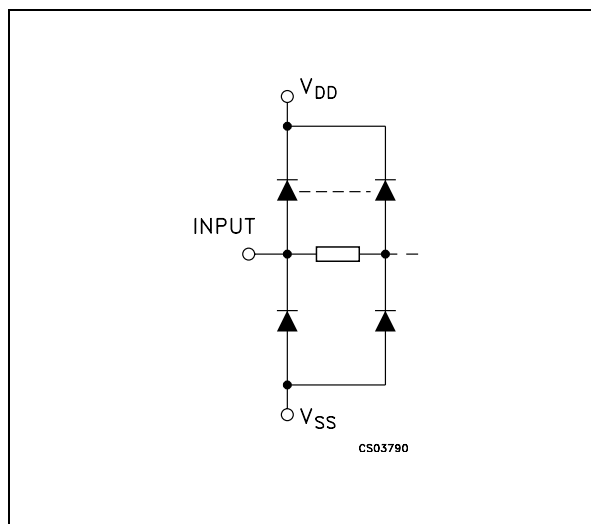

PIN DESCRIPTION

PIN No	SYMBOL	NAME AND FUNCTION
1, 2, 5, 6, 8, 9, 12, 13	A, B, C, D, E, F, G, H	Data Inputs
3, 4, 10, 11	J, K, L, M	Data Outputs
7	V _{SS}	Negative Supply Voltage
14	V _{DD}	Positive Supply Voltage

TRUTH TABLE

INPUTS		OUTPUTS
A, C, E, G	B, D, F, H	J, K, L, M
L	L	H
L	H	H
H	L	H
H	H	L

ABSOLUTE MAXIMUM RATINGS

Symbol	Parameter	Value	Unit
V _{DD}	Supply Voltage	-0.5 to +22	V
V _I	DC Input Voltage	-0.5 to V _{DD} + 0.5	V
I _I	DC Input Current	± 10	mA
P _D	Power Dissipation per Package	200	mW
	Power Dissipation per Output Transistor	100	mW
T _{op}	Operating Temperature	-55 to +125	°C
T _{stg}	Storage Temperature	-65 to +150	°C

Absolute Maximum Ratings are those values beyond which damage to the device may occur. Functional operation under these conditions is not implied.

All voltage values are referred to V_{SS} pin voltage.

RECOMMENDED OPERATING CONDITIONS

Symbol	Parameter	Value	Unit
V _{DD}	Supply Voltage	3 to 20	V
V _I	Input Voltage	0 to V _{DD}	V
T _{op}	Operating Temperature	-55 to 125	°C

HCF4093B
DC SPECIFICATIONS

Symbol	Parameter	Test Condition				Value						Unit	
		V _I (V)	V _O (V)	I _{oI} (μ A)	V _{DD} (V)	T _A = 25°C			-40 to 85°C		-55 to 125°C		
						Min.	Typ.	Max.	Min.	Max.	Min.		Max.
I _L	Quiescent Current	0/5			5		0.02	1		30		30	μ A
		0/10			10		0.02	2		60		60	
		0/15			15		0.02	4		120		120	
		0/20			20		0.04	20		600		600	
V _{OH}	High Level Output Voltage	0/5		<1	5	4.95			4.95		4.95		V
		0/10		<1	10	9.95			9.95		9.95		
		0/15		<1	15	14.95			14.95		14.95		
V _{OL}	Low Level Output Voltage	5/0		<1	5		0.05			0.05		0.05	V
		10/0		<1	10		0.05			0.05		0.05	
		15/0		<1	15		0.05			0.05		0.05	
V _P	Positive Trigger Threshold Voltage	a			5	2.2	2.9	3.6	2.2	3.6	2.2	3.6	V
		a			10	4.6	5.9	7.1	4.6	7.1	4.6	7.1	
		a			15	6.8	8.8	10.8	6.8	10.8	6.8	10.8	
		b			5	2.6	3.3	4.0	2.6	4	2.6	4	
		b			10	5.6	7	8.2	5.6	8.2	5.6	8.2	
		b			15	6.3	9.4	12.7	6.3	12.7	6.3	12.7	
V _N	Negative Trigger Threshold Voltage	a			5	0.9	1.9	2.8	0.9	2.8	0.9	2.8	V
		a			10	2.5	3.9	5.2	2.5	5.2	2.5	5.2	
		a			15	4	5.8	7.4	4	7.4	4	7.4	
		b			5	1.4	2.3	3.2	1.4	3.2	1.4	3.2	
		b			10	3.4	5.1	6.6	3.4	6.6	3.4	6.6	
		b			15	4.8	7.3	9.6	4.8	9.6	4.8	9.6	
V _H	Hysteresis Voltage	a			5	0.3	0.9	1.6	0.3	1.6	0.3	1.6	V
		a			10	1.2	2.3	3.4	1.2	3.4	1.2	3.4	
		a			15	1.6	3.5	5	1.6	5	1.6	5	
		b			5	0.3	0.9	1.6	0.3	1.6	0.3	1.6	
		b			10	1.2	2.3	3.4	1.2	3.4	1.2	3.4	
		b			15	1.6	3.5	5	1.6	5	1.6	5	
I _{OH}	Output Drive Current	0/5	2.5	<1	5	-1.36	-3.2		-1.15		-1.1		mA
		0/5	4.6	<1	5	-0.44	-1		-0.36		-0.36		
		0/10	9.5	<1	10	-1.1	-2.6		-0.9		-0.9		
		0/15	13.5	<1	15	-3.0	-6.8		-2.4		-2.4		
I _{OL}	Output Sink Current	0/5	0.4	<1	5	0.44	1		0.36		0.36		mA
		0/10	0.5	<1	10	1.1	2.6		0.9		0.9		
		0/15	1.5	<1	15	3.0	6.8		2.4		2.4		
I _I	Input Leakage Current	0/18	Any Input		18		$\pm 10^{-5}$	± 0.1		± 1		± 1	μ A
C _I	Input Capacitance		Any Input				5	7.5					pF

 The Noise Margin for both "1" and "0" level is: 1V min. with V_{DD}=5V, 2V min. with V_{DD}=10V, 2.5V min. with V_{DD}=15V

 a : Input on terminals 1, 5, 8, 12 or 2, 6, 9, 13; other inputs to V_{DD}.

 b : Input on terminals 1 and 2, 5 and 6, 8 and 9, or 12 and 13; other inputs to V_{DD}.

HCF4093B

DYNAMIC ELECTRICAL CHARACTERISTICS ($T_{amb} = 25^{\circ}C$, $C_L = 50pF$, $R_L = 200K\Omega$, $t_r = t_f = 20 ns$)

Symbol	Parameter	Test Condition		Value (*)			Unit
		V_{DD} (V)		Min.	Typ.	Max.	
t_{PLH} t_{PHL}	Propagation Delay Time	5			190	380	ns
		10			90	180	
		15			65	130	
t_{TLH} t_{THL}	Output Transition Time	5			100	200	ns
		10			50	100	
		15			40	80	

(*) Typical temperature coefficient for all V_{DD} value is 0.3 %/°C.

TEST CIRCUIT

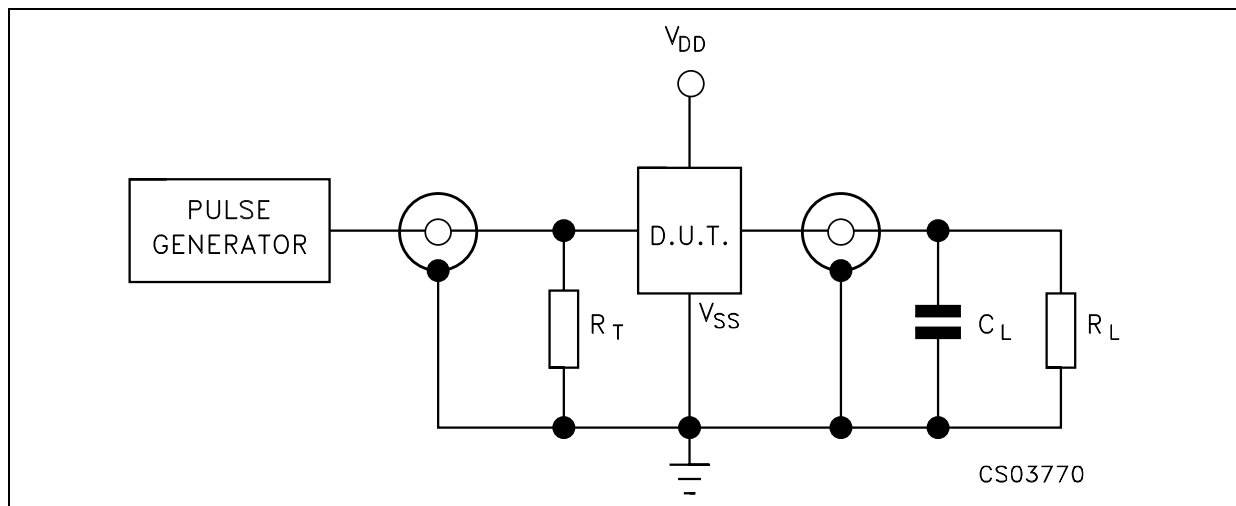

$C_L = 50pF$ or equivalent (includes jig and probe capacitance)
 $R_L = 200K\Omega$
 $R_T = Z_{OUT}$ of pulse generator (typically 50Ω)

WAVEFORM : PROPAGATION DELAY TIMES ($f=1MHz$; 50% duty cycle)

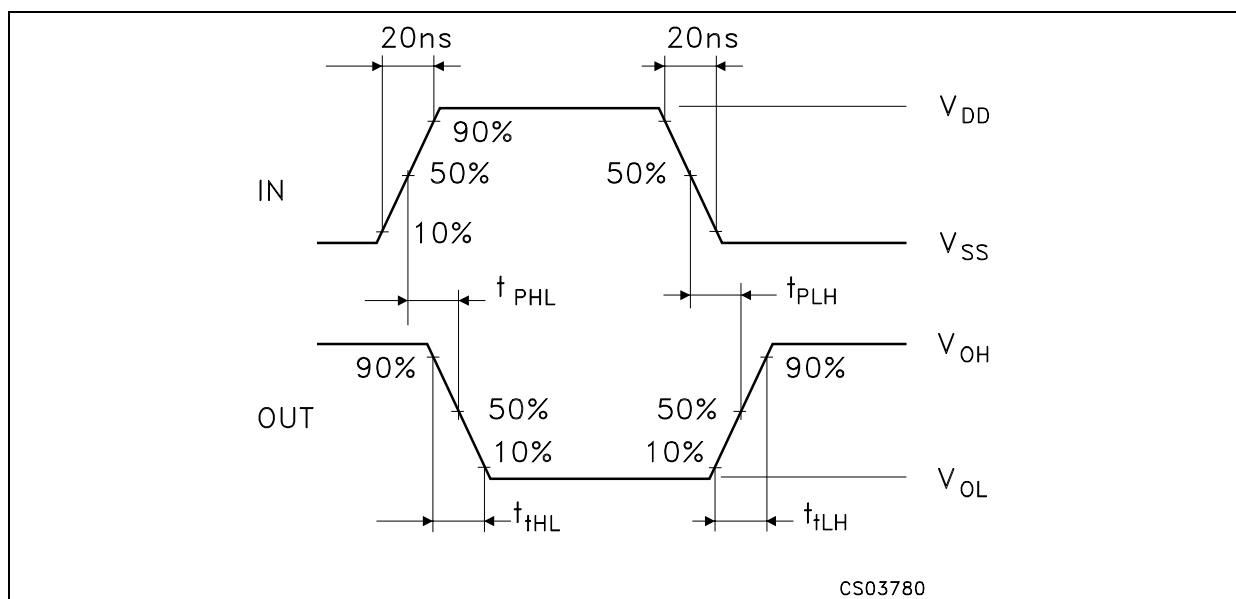

HCF4093B

Plastic DIP-14 MECHANICAL DATA

DIM.	mm.			inch		
	MIN.	TYP	MAX.	MIN.	TYP.	MAX.
a1	0.51			0.020		
B	1.39		1.65	0.055		0.065
b		0.5			0.020	
b1		0.25			0.010	
D			20			0.787
E		8.5			0.335	
e		2.54			0.100	
e3		15.24			0.600	
F			7.1			0.280
l			5.1			0.201
L		3.3			0.130	
Z	1.27		2.54	0.050		0.100

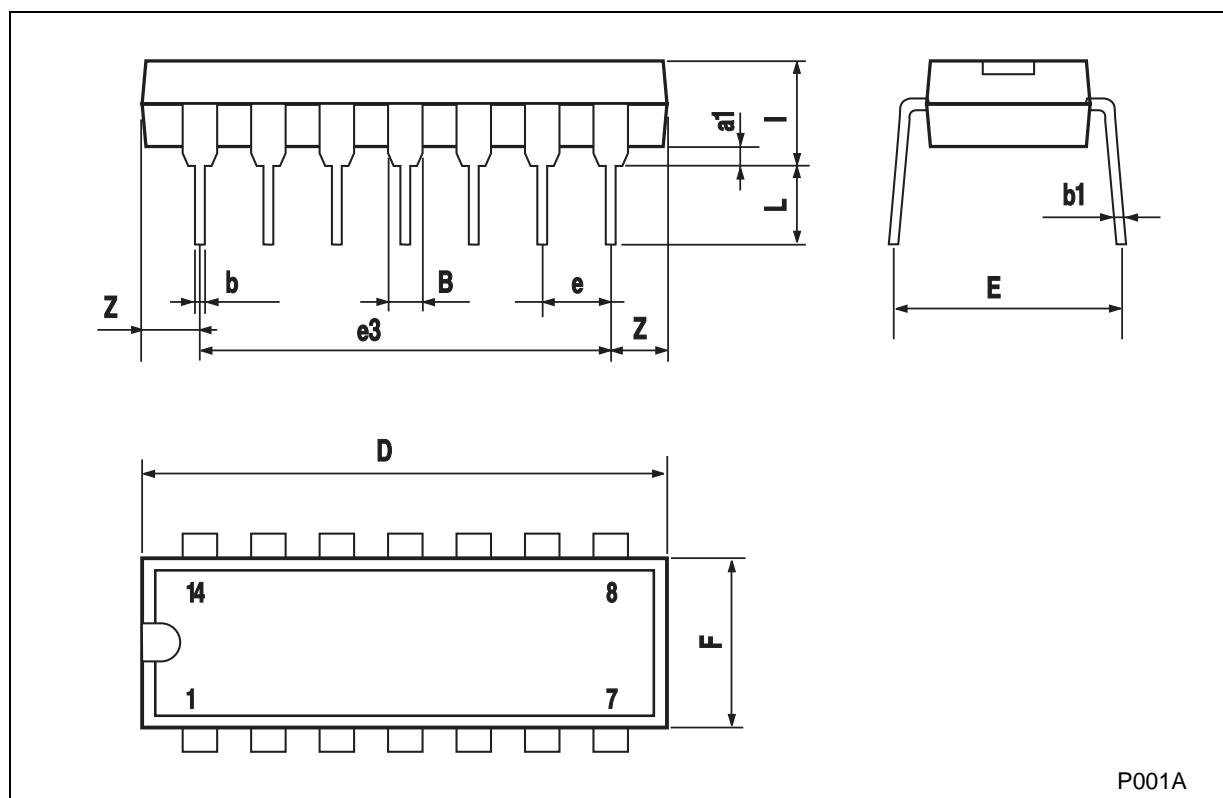

HCF4093B

SO-14 MECHANICAL DATA

DIM.	mm.			inch		
	MIN.	TYP	MAX.	MIN.	TYP.	MAX.
A			1.75			0.068
a1	0.1		0.2	0.003		0.007
a2			1.65			0.064
b	0.35		0.46	0.013		0.018
b1	0.19		0.25	0.007		0.010
C		0.5			0.019	
c1	45° (typ.)					
D	8.55		8.75	0.336		0.344
E	5.8		6.2	0.228		0.244
e		1.27			0.050	
e3		7.62			0.300	
F	3.8		4.0	0.149		0.157
G	4.6		5.3	0.181		0.208
L	0.5		1.27	0.019		0.050
M			0.68			0.026
S	8° (max.)					

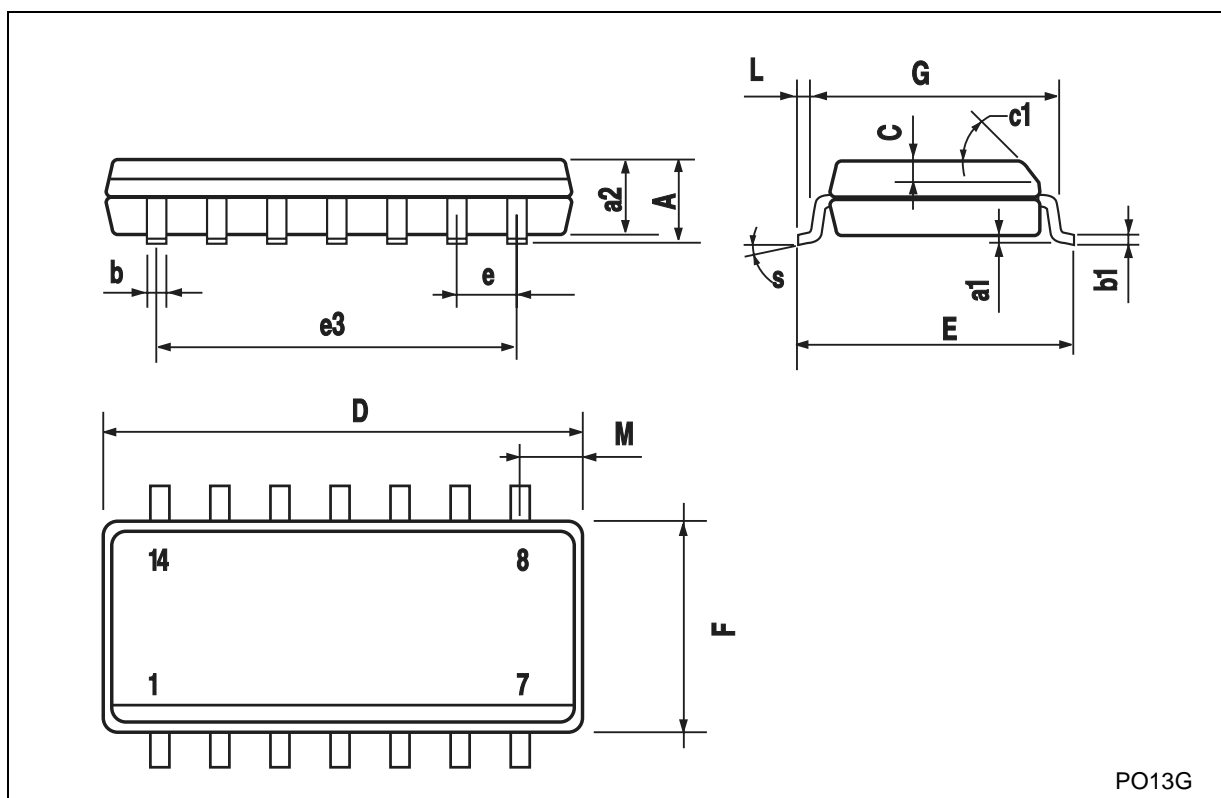

PO13G

HCF4093B

Information furnished is believed to be accurate and reliable. However, STMicroelectronics assumes no responsibility for the consequences of use of such information nor for any infringement of patents or other rights of third parties which may result from its use. No license is granted by implication or otherwise under any patent or patent rights of STMicroelectronics. Specifications mentioned in this publication are subject to change without notice. This publication supersedes and replaces all information previously supplied. STMicroelectronics products are not authorized for use as critical components in life support devices or systems without express written approval of STMicroelectronics.

© The ST logo is a registered trademark of STMicroelectronics

© 2001 STMicroelectronics - Printed in Italy - All Rights Reserved
STMicroelectronics GROUP OF COMPANIES

Australia - Brazil - China - Finland - France - Germany - Hong Kong - India - Italy - Japan - Malaysia - Malta - Morocco
Singapore - Spain - Sweden - Switzerland - United Kingdom

© <http://www.st.com>