

## Excellent Integrated System Limited

Stocking Distributor

Click to view price, real time Inventory, Delivery & Lifecycle Information:

[STMicroelectronics](#)  
[L295](#)

For any questions, you can email us directly:  
[sales@integrated-circuit.com](mailto:sales@integrated-circuit.com)



# L295

## DUAL SWITCH-MODE SOLENOID DRIVER

- HIGH CURRENT CAPABILITY (up to 2.5A per channel)
- HIGH VOLTAGE OPERATION (up to 46V for power stage)
- HIGH EFFICIENCY SWITCHMODE OPERATION
- REGULATED OUTPUT CURRENT (adjustable)
- FEW EXTERNAL COMPONENTS
- SEPARATE LOGIC SUPPLY
- THERMAL PROTECTION



### DESCRIPTION

The L295 is a monolithic integrated circuit in a 15-lead Multiwatt® package; it incorporates all the functions for direct interfacing between digital circuitry and inductive loads.

The L295 is designed to accept standard micro-processor logic levels at the inputs and can drive 2 solenoids. The output current is completely con-

trolled by means of a switch-ing technique allowing very efficient operation.

Furthermore, it includes an enable input and dual supplies (for interfacing with peripherals running at a higher voltage than the logic).

The L295 is particularly suitable for applications such as hammer driving in matrix printers, step motor driving and electromagnet controllers.

### BLOCK DIAGRAM

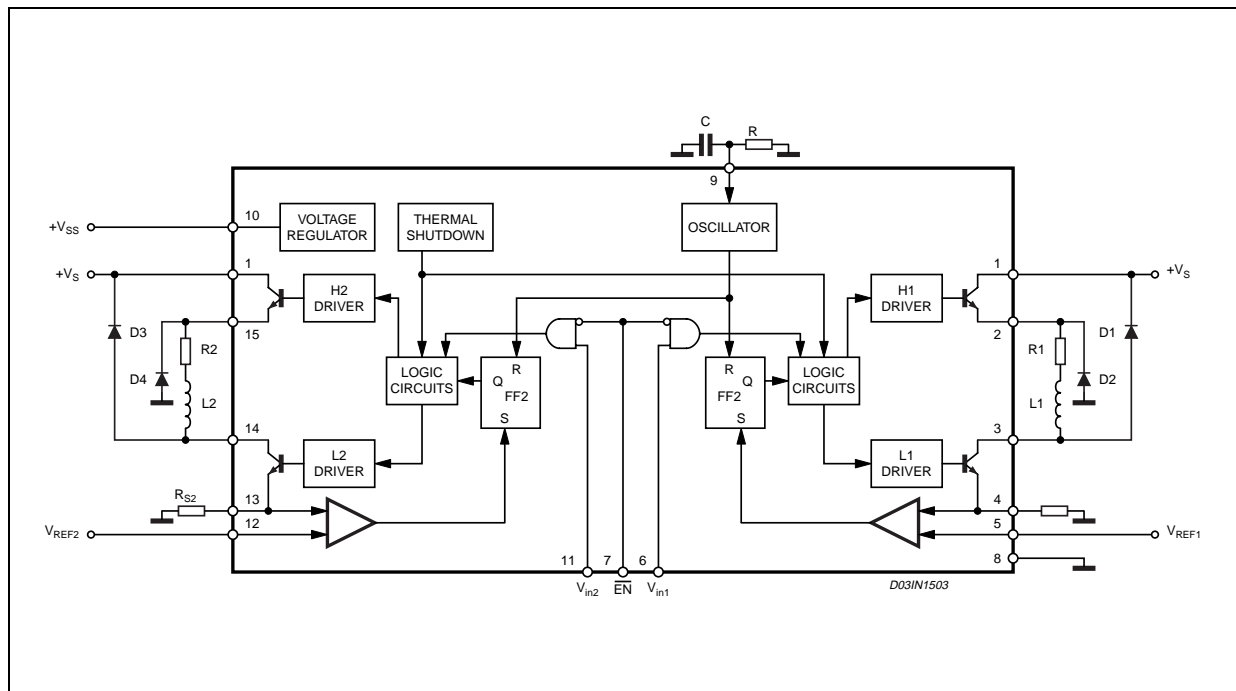

## L295

### ABSOLUTE MAXIMUM RATINGS

Symbol	Parameter	Value	Unit
V <sub>S</sub>	Supply voltage	50	V
V <sub>SS</sub>	Logic supply voltage	12	V
V <sub>EN</sub> , V <sub>i</sub>	Enable and input voltage	7	V
V <sub>ref</sub>	Reference voltage	7	V
I <sub>o</sub>	Peak output current (each channel) - non repetitive (t = 100 μsec) - repetitive (80% on - 20% off; T <sub>on</sub> = 10ms) - DC operation	3 2.5 2	A A A
P <sub>tot</sub>	Total power dissipation (at T <sub>case</sub> = 75 °C)	25	W
T <sub>stg</sub> , T <sub>j</sub>	Storage and junction temperature	- 40 to 150	°C

### CONNECTION DIAGRAM

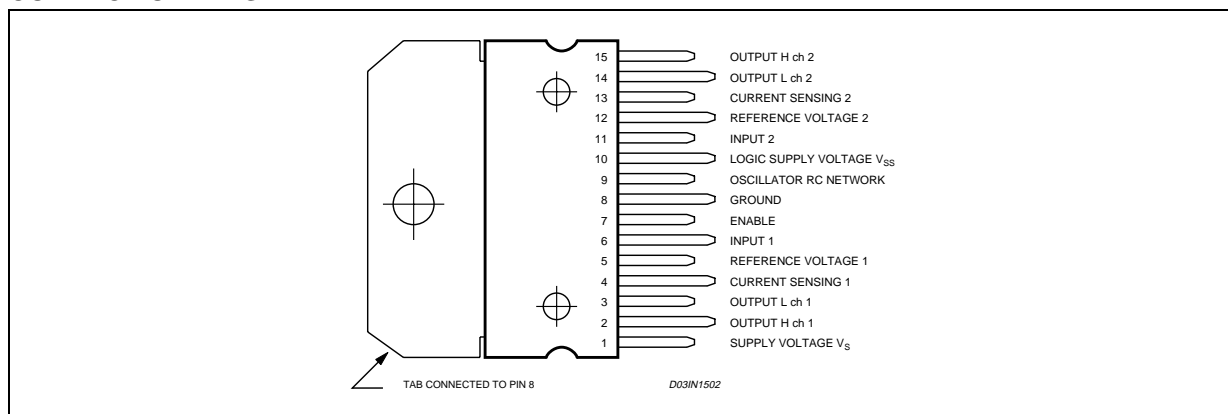

### THERMAL DATA

Symbol	Parameter	Value	Unit
R <sub>th-j-case</sub>	Thermal resistance junction-case	max 3	°C/W
R <sub>th-j-amb</sub>	Thermal resistance junction-ambient	max 35	°C/W

**ELECTRICAL CHARACTERISTICS** (Refer to the application circuit, V<sub>ss</sub> = 5V, V<sub>s</sub> = 36V; T<sub>j</sub> = 25°C; L = Low; H = High; unless otherwise specified)

Symbol	Parameter	Test Condition	Min.	Typ.	Max.	Unit
V <sub>S</sub>	Supply Voltage		12		46	V
V <sub>SS</sub>	Logic Supply Voltage		4.75		10	V
I <sub>d</sub>	Quiescent Drain Current (from V <sub>SS</sub> )	V <sub>S</sub> = 46V; V <sub>i1</sub> = V <sub>i2</sub> = V <sub>EN</sub> = L			4	mA
I <sub>SS</sub>	Quiescent Drain Current (from V <sub>S</sub> )	V <sub>SS</sub> = 10V			46	mA
V <sub>i1</sub> , V <sub>i2</sub>	Input Voltage	Low High	-0.3 2.2		0.8 7	V V

**ELECTRICAL CHARACTERISTICS** (continued)

Symbol	Parameter	Test Condition	Min.	Typ.	Max.	Unit
$V_{EN}$	Enable Input Voltage	Low High	-0.3 2.2		0.8 7	V V
$I_{i1}, I_{i2}$	Input Current	$V_{i1} = V_{i2} = L$ $V_{i1} = V_{i2} = H$			-100 10	$\mu A$ $\mu A$
$I_{EN}$	Enable Input Current	$V_{EN} = L$ $V_{EN} = H$			-100 10	$\mu A$ $\mu A$
$V_{ref1}, V_{ref2}$	Input Reference Voltage		0.2		2	V
$I_{ref1}, I_{ref2}$	Input Reference Voltage				-5	$\mu A$
$F_{osc}$	Oscillator Frequency	$C = 3.9 \text{ nF}; R = 9.1 \text{ K}\Omega$		25	46	KHz
$I_p$	Transconductance (each ch.)	$V_{ref} = 1V$	1.9	2	2.1	A/V
$V_{ref}$						
$V_{ref1}, V_{ref2}$	Input Reference Voltage		0.2		2	V
$V_{ref1}, V_{ref2}$	Input Reference Voltage		0.2		2	V
$V_{drop}$	Total Output Voltage (each channel) (*)	$I_o = 2 \text{ A}$		2.8	3.6	V
$V_{sens1}, V_{sens2}$	External sensing resistors voltage drop				2	V

(\*)  $V_{drop} = V_{CEsat} Q1 + V_{CEsat} Q2$ .

**APPLICATION CIRCUIT**

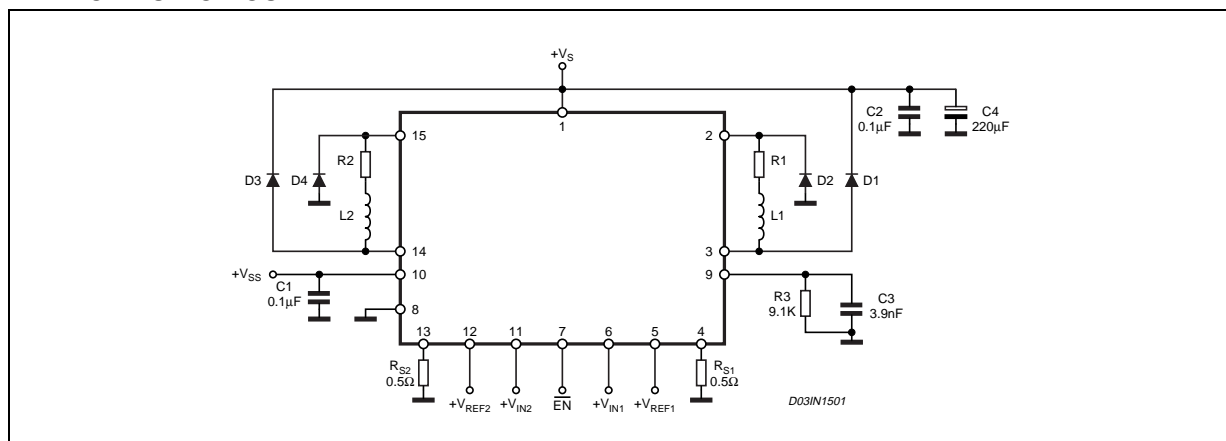

D2, D4 = 2A High speed diodes  $t_{rr} \leq 200 \text{ ns}$   
 D1, D3 = 1A High speed diodes  $t_{rr} \leq 200 \text{ ns}$

$R1 = R2 = 2W$   
 $L1 = L2 = 5 \text{ mH}$

**FUNCTIONAL DESCRIPTION**

The L295 incorporates two independent driver channels with separate inputs and outputs, each capable of driving an inductive load (see block diagram). The device is controlled by three microprocessor compatible digital inputs and two analog inputs.

## L295

These inputs are:

- **EN** chip enable (digital input, active low), enables both channels when in the low state.
- **V<sub>in1</sub>**, **V<sub>in2</sub>** channel inputs (digital inputs, active high), enable each channel independently.  
A channel is activated when both EN and the appropriate channel input are active.
- **V<sub>ref1</sub>**, **V<sub>ref2</sub>** reference voltages (analog inputs), used to program the peak load currents. Peak load current is proportional to V<sub>ref</sub>.

Since the two channels are identical, only channel one will be described. The following description applies also the channel two, replacing FF2 for FF1, V<sub>ref</sub> for V<sub>ref1</sub> etc.

When the channel is activated by low level on the EN input and a high level on the channel input, V<sub>in2</sub>, the output transistors Q1 and Q2 switch on and current flows in the load according to the exponential law:

$$I = \frac{V}{R1} \left( 1 - e^{-\frac{R1t}{L1}} \right)$$

where:

R1 and R2 are the resistance and inductance of the load and V is the voltage available on the load (V<sub>s</sub> - V<sub>drop</sub> - V<sub>sense</sub>).

The current increases until the voltage on the external sensing resistor, R<sub>S1</sub>, reaches the reference voltage, V<sub>ref1</sub>. This peak current, I<sub>p1</sub>, is given by:

$$I_{p1} = \frac{V_{ref1}}{R_{S1}}$$

At this point the comparator output, Vomp1, sets the RS flip-flop, FF1, that turns off the output transistor, Q1. The load current flowing through D2, Q2, R<sub>S1</sub>, decreases according to the law:

$$I = \left( \frac{V_A}{R_1} + I_{p1} \right) e^{-\frac{R1t}{L1} - \frac{V_A}{R1}}$$

where V<sub>A</sub> = V<sub>CEsat</sub> Q2 + V<sub>sense</sub> + V<sub>D2</sub>

If the oscillator pin (9) is connected to ground the load current falls to zero as shown in fig. 1.

At this time t<sub>2</sub> the channel 1 is disabled, by taking the inputs V<sub>in1</sub> low and/or  $\overline{EN}$  high, and the output transistor Q2 is turned off. The load current flows through D2 and D1 according to the law:

$$I = \left( \frac{V_B}{R_1} + I_{T2} \right) e^{-\frac{R1t}{L1} - \frac{V_B}{R1}}$$

where V<sub>B</sub> = V<sub>S</sub> + V<sub>D1</sub> + V<sub>D2</sub>

I<sub>T2</sub> = current value at the time t<sub>2</sub>.

Fig. 2 in shows the current waveform obtained with an RC network connected between pin 9 and ground. From to t<sub>1</sub> the current increases as in fig.1. A difference exists at the time t<sub>2</sub> because the current starts to increase again. At this time a pulse is produced by the oscillator circuit that resets the flip. flop, FF1, and switches on the output transistor, Q1. The current increases until the drop on the sensing resistor R<sub>S1</sub> is equal to V<sub>ref1</sub> (t<sub>3</sub>) and the cycle repeats.

The switching frequency depends on the value R and C, as shown in fig. 4 and must be chosen in the range 10 to 30 KHz. It is possible with external hardware to change the reference voltage V<sub>ref</sub> in order to obtain a high peak current I<sub>p</sub> and a lower holding current I<sub>h</sub> (see fig. 3).

The L295 is provided with a thermal protection that switches off all the output transistors when the junction temperature exceeds 150°C. The presence of a hysteresis circuit makes the IC work again after a fall of

the junction temperature of about 20°C.

The analog input pins ( $V_{ref1}$ ,  $V_{ref2}$ ) can be left open or connected to  $V_{SS}$ ; in this case the circuit works with an internal reference voltage of about 2.5V and the peak current in the load is fixed only by the value of  $R_S$ :

$$I_P = \frac{2.5}{R_S}$$

**SIGNAL WAVEFORMS**

**Figure 1. Load current waveform with pin 9 connected to GND.**

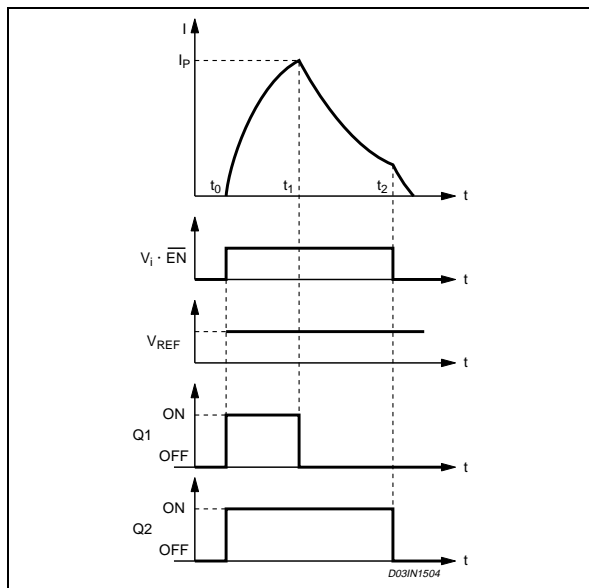

**Figure 2. Load current waveform with external R-C network connected between pin 9 and ground.**

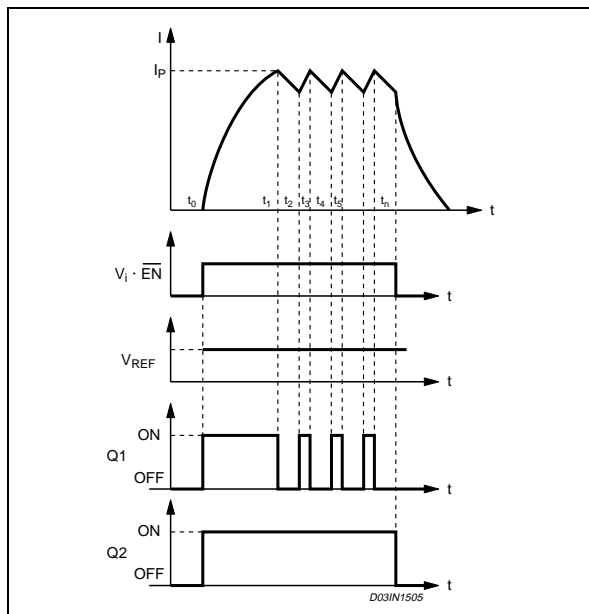

**Figure 3. With  $V_{ref}$  changed by hardware.**

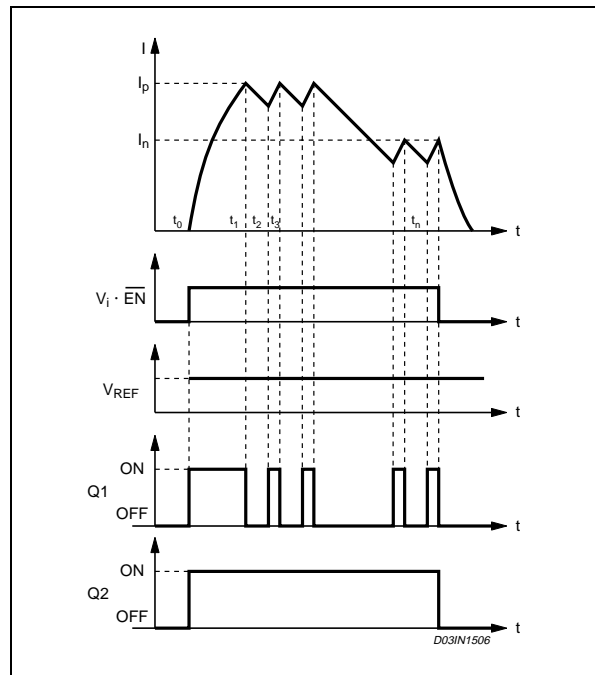

**Figure 4. Switching frequency vs. values of R and C.**

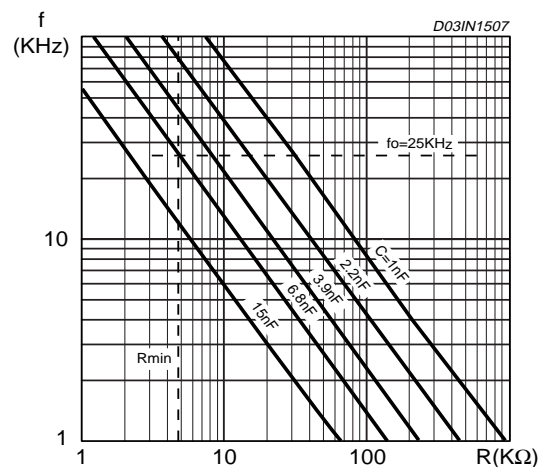

**L295**

DIM.	mm			inch		
	MIN.	TYP.	MAX.	MIN.	TYP.	MAX.
A			5			0.197
B			2.65			0.104
C			1.6			0.063
D		1			0.039	
E	0.49		0.55	0.019		0.022
F	0.66		0.75	0.026		0.030
G	1.02	1.27	1.52	0.040	0.050	0.060
G1	17.53	17.78	18.03	0.690	0.700	0.710
H1	19.6			0.772		
H2			20.2			0.795
L	21.9	22.2	22.5	0.862	0.874	0.886
L1	21.7	22.1	22.5	0.854	0.870	0.886
L2	17.65		18.1	0.695		0.713
L3	17.25	17.5	17.75	0.679	0.689	0.699
L4	10.3	10.7	10.9	0.406	0.421	0.429
L7	2.65		2.9	0.104		0.114
M	4.25	4.55	4.85	0.167	0.179	0.191
M1	4.63	5.08	5.53	0.182	0.200	0.218
S	1.9		2.6	0.075		0.102
S1	1.9		2.6	0.075		0.102
Dia1	3.65		3.85	0.144		0.152

**OUTLINE AND MECHANICAL DATA**

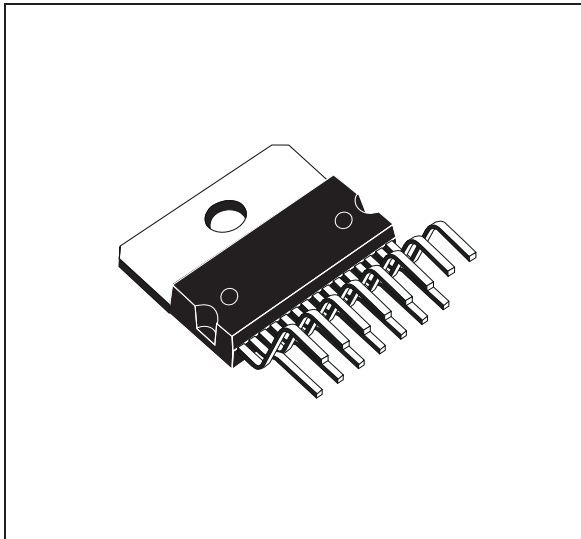

**Multiwatt15 V**

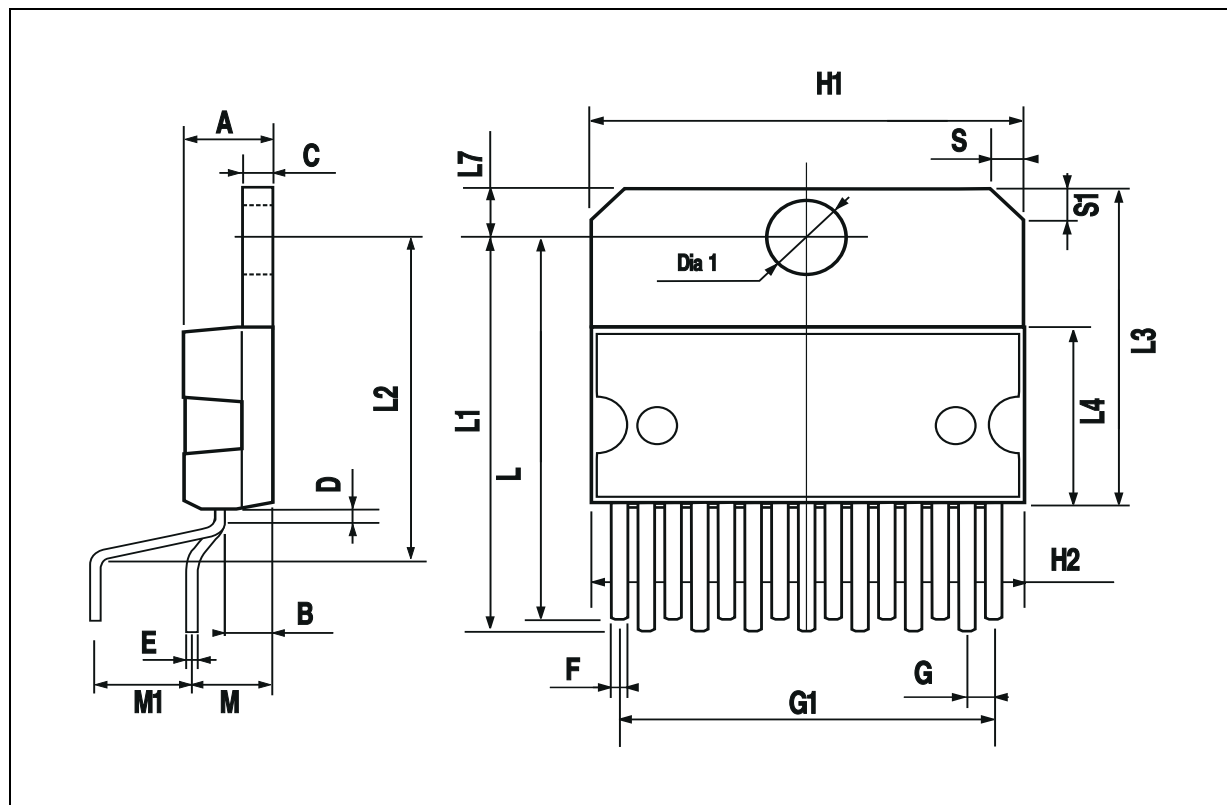

## L295

---

Information furnished is believed to be accurate and reliable. However, STMicroelectronics assumes no responsibility for the consequences of use of such information nor for any infringement of patents or other rights of third parties which may result from its use. No license is granted by implication or otherwise under any patent or patent rights of STMicroelectronics. Specifications mentioned in this publication are subject to change without notice. This publication supersedes and replaces all information previously supplied. STMicroelectronics products are not authorized for use as critical components in life support devices or systems without express written approval of STMicroelectronics.

The ST logo is a registered trademark of STMicroelectronics.  
All other names are the property of their respective owners

© 2003 STMicroelectronics - All rights reserved

**STMicroelectronics GROUP OF COMPANIES**

Australia - Belgium - Brazil - Canada - China - Czech Republic - Finland - France - Germany - Hong Kong - India - Israel - Italy - Japan -  
Malaysia - Malta - Morocco - Singapore - Spain - Sweden - Switzerland - United Kingdom - United States

[www.st.com](http://www.st.com)