

Excellent Integrated System Limited

Stocking Distributor

Click to view price, real time Inventory, Delivery & Lifecycle Information:

[STMicroelectronics](#)
[M74HCT374B1R](#)

For any questions, you can email us directly:

sales@integrated-circuit.com



M74HCT374

OCTAL D-TYPE FLIP FLOP WITH 3 STATE OUTPUT NON INVERTING

- **HIGH SPEED:**
 $f_{MAX} = 50 \text{ MHz (TYP.) at } V_{CC} = 4.5V$
- **LOW POWER DISSIPATION:**
 $I_{CC} = 4\mu A(\text{MAX.}) \text{ at } T_A=25^\circ C$
- **COMPATIBLE WITH TTL OUTPUTS :**
 $V_{IH} = 2V \text{ (MIN.) } V_{IL} = 0.8V \text{ (MAX)}$
- **BALANCED PROPAGATION DELAYS:**
 $t_{PLH} \cong t_{PHL}$
- **SYMMETRICAL OUTPUT IMPEDANCE:**
 $|I_{OH}| = I_{OL} = 6mA \text{ (MIN)}$
- **PIN AND FUNCTION COMPATIBLE WITH 74 SERIES 374**

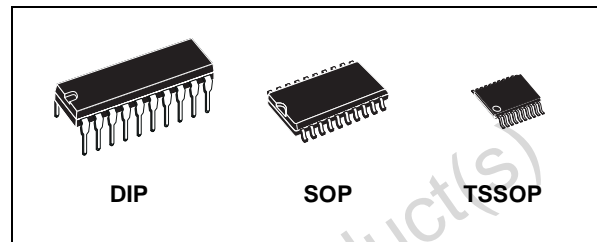

ORDER CODES

PACKAGE	TUBE	T & R
DIP	M74HCT374B1R	
SOP	M74HCT374M1R	M74HCT374RM13TR
TSSOP		M74HCT374TTR

DESCRIPTION

The M74HCT374 is an high speed CMOS OCTAL D-TYPE FLIP FLOP WITH 3-STATE OUTPUTS NON INVERTING fabricated with silicon gate C²MOS technology.

This 8 bit D-TYPE FLIP FLOP is controlled by a clock input (CK) and an output enable input (\overline{OE}). On the positive transition of the clock, the Q outputs will be set to the logic state that were setup at the D inputs.

While the \overline{OE} input is at low level, the eight outputs will be in a normal logic state (high or low logic level) and while \overline{OE} is at high level the outputs will be in a high impedance state.

The output control does not affect the internal operation of flip-flops; that is, the old data can be retained or the new data can be entered even while the outputs are off.

The M74HCT374 is designed to directly interface HSC²MOS systems with TTL and NMOS components.

All inputs are equipped with protection circuits against static discharge and transient excess voltage.

PIN CONNECTION AND IEC LOGIC SYMBOLS

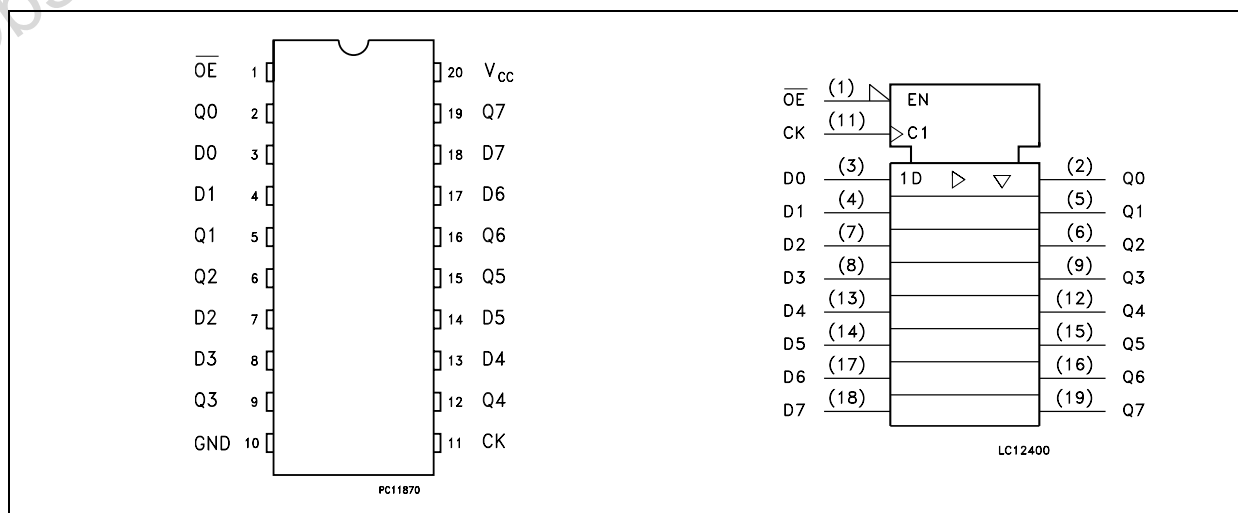

M74HCT374

INPUT AND OUTPUT EQUIVALENT CIRCUIT

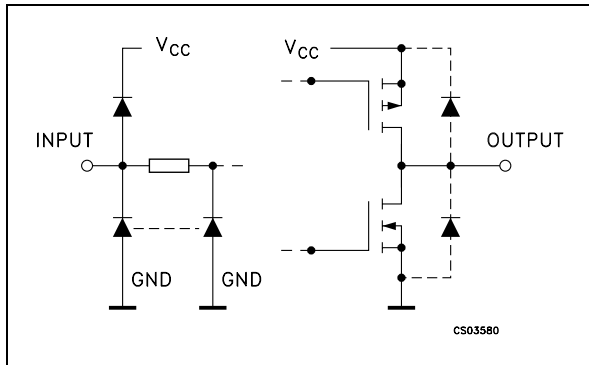

PIN DESCRIPTION

PIN No	SYMBOL	NAME AND FUNCTION
1	OE	3 State Output Enable Input (Active LOW)
2, 5, 6, 9, 12, 15, 16, 19	Q0 to Q7	3 State Outputs
3, 4, 7, 8, 13, 14, 17, 18	D0 to D7	Data Inputs
11	CK	Clock Input (LOW to HIGH, edge triggered)
10	GND	Ground (0V)
20	V _{CC}	Positive Supply Voltage

TRUTH TABLE

INPUTS			OUTPUT
$\overline{\text{OE}}$	CK	D	Q
H	X	X	Z
L		X	NO CHANGE
L		L	L
L		H	H

X: Don't Care
Z: High Impedance

LOGIC DIAGRAM

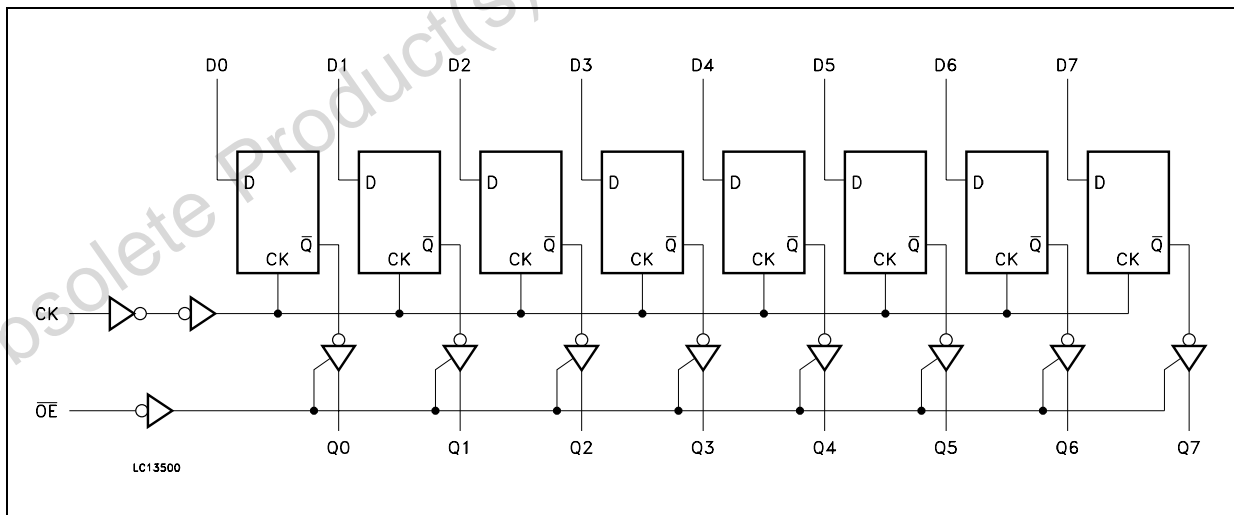

This logic diagram has not been used to estimate propagation delays

M74HCT374

ABSOLUTE MAXIMUM RATINGS

Symbol	Parameter	Value	Unit
V_{CC}	Supply Voltage	-0.5 to +7	V
V_I	DC Input Voltage	-0.5 to $V_{CC} + 0.5$	V
V_O	DC Output Voltage	-0.5 to $V_{CC} + 0.5$	V
I_{IK}	DC Input Diode Current	± 20	mA
I_{OK}	DC Output Diode Current	± 20	mA
I_O	DC Output Current	± 35	mA
I_{CC} or I_{GND}	DC V_{CC} or Ground Current	± 70	mA
P_D	Power Dissipation	500(*)	mW
T_{stg}	Storage Temperature	-65 to +150	$^{\circ}C$
T_L	Lead Temperature (10 sec)	300	$^{\circ}C$

Absolute Maximum Ratings are those values beyond which damage to the device may occur. Functional operation under these conditions is not implied

(*) 500mW at 65 $^{\circ}C$; derate to 300mW by 10mW/ $^{\circ}C$ from 65 $^{\circ}C$ to 85 $^{\circ}C$

RECOMMENDED OPERATING CONDITIONS

Symbol	Parameter	Value	Unit
V_{CC}	Supply Voltage	4.5 to 5.5	V
V_I	Input Voltage	0 to V_{CC}	V
V_O	Output Voltage	0 to V_{CC}	V
T_{op}	Operating Temperature	-55 to 125	$^{\circ}C$
t_r, t_f	Input Rise and Fall Time ($V_{CC} = 4.5$ to $5.5V$)	0 to 500	ns

M74HCT374

DC SPECIFICATION

Symbol	Parameter	Test Condition		Value						Unit	
		V _{CC} (V)		T _A = 25°C			-40 to 85°C		-55 to 125°C		
				Min.	Typ.	Max.	Min.	Max.	Min.		Max.
V _{IH}	High Level Input Voltage	4.5 to 5.5		2.0			2.0		2.0		V
V _{IL}	Low Level Input Voltage	4.5 to 5.5				0.8		0.8		0.8	V
V _{OH}	High Level Output Voltage	4.5	I _O = -20 μA	4.4	4.5		4.4		4.4		V
			I _O = -6.0 mA	4.18	4.31		4.13		4.10		
V _{OL}	Low Level Output Voltage	4.5	I _O = 20 μA		0.0	0.1		0.1		0.1	V
			I _O = 6.0 mA		0.17	0.26		0.33		0.40	
I _I	Input Leakage Current	5.5	V _I = V _{CC} or GND			± 0.1		± 1		± 1	μA
I _{OZ}	High Impedance Output Leakage Current	5.5	V _I = V _{IH} or V _{IL} V _O = V _{CC} or GND			± 0.5		± 5		± 10	μA
I _{CC}	Quiescent Supply Current	5.5	V _I = V _{CC} or GND			4		40		80	μA
Δ I _{CC}	Additional Worst Case Supply Current	5.5	Per Input pin V _I = 0.5V or V _I = 2.4V Other Inputs at V _{CC} or GND I _O = 0			2.0		2.9		3.0	mA

AC ELECTRICAL CHARACTERISTICS (C_L = 50 pF, Input t_r = t_f = 6ns)

Symbol	Parameter	Test Condition		Value						Unit	
		V _{CC} (V)	C _L (pF)	T _A = 25°C			-40 to 85°C		-55 to 125°C		
				Min.	Typ.	Max.	Min.	Max.	Min.		Max.
t _{TLH} t _{THL}	Output Transition Time	4.5	50		7	12		15		18	ns
t _{PLH} t _{PHL}	Propagation Delay Time (CLOCK-Q,Q)	4.5	50		20	30		38		45	ns
		4.5	150		25	38		48		57	
t _{PZL} t _{PZH}	Output Enable Time	4.5	50	R _L = 1 KΩ	17	30		38		45	ns
		4.5	150		25	38		48		57	
t _{PLZ} t _{PHZ}	Output Disable Time	4.5	50	R _L = 1 KΩ	16	28		35		42	ns
f _{MAX}	Maximum Clock Frequency	4.5	50		31	50		25		21	MHz
t _{W(L)} t _{W(H)}	Minimum Pulse Width (CLOCK)	4.5	50			15		19		23	ns
t _s	Minimum Set-Up Time	4.5	50			15		19		23	ns
t _h	Minimum Hold Time	4.5	50			0		0		0	ns

M74HCT374

CAPACITIVE CHARACTERISTICS

Symbol	Parameter	Test Condition		Value						Unit	
		V _{CC} (V)		T _A = 25°C			-40 to 85°C		-55 to 125°C		
				Min.	Typ.	Max.	Min.	Max.	Min.		Max.
C _{IN}	Input Capacitance				5	10		10		10	pF
C _{OUT}	Output Capacitance				10						pF
C _{PD}	Power Dissipation Capacitance (note 1)				48						pF

1) C_{PD} is defined as the value of the IC's internal equivalent capacitance which is calculated from the operating current consumption without load. (Refer to Test Circuit). Average operating current can be obtained by the following equation: $I_{CC(oper)} = C_{PD} \times V_{CC} \times f_{IN} + I_{CC}/8$ (per Flip Flop) and the C_{PD} when n pcs of Flip Flop operate, can be gained by the following equation: $C_{PD(TOTAL)} = 30 + 18 \times n$ (pF)

TEST CIRCUIT

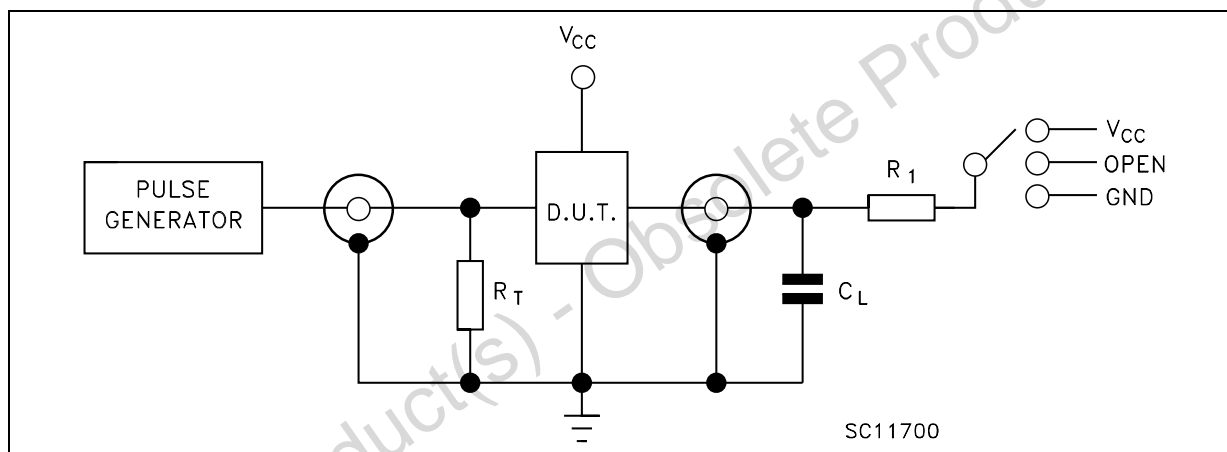

TEST	SWITCH
t _{PLH} , t _{PHL}	Open
t _{PZL} , t _{PLZ}	V _{CC}
t _{PZH} , t _{PHZ}	GND

C_L = 50pF/150pF or equivalent (includes jig and probe capacitance)

R₁ = 1KΩ or equivalent

R_T = Z_{OUT} of pulse generator (typically 50Ω)

M74HCT374

WAVEFORM 1: CK TO Qn PROPAGATION DELAYS, MAXIMUM CK FREQUENCY, Dn TO CK SETUP AND HOLD TIMES (f=1MHz; 50% duty cycle)

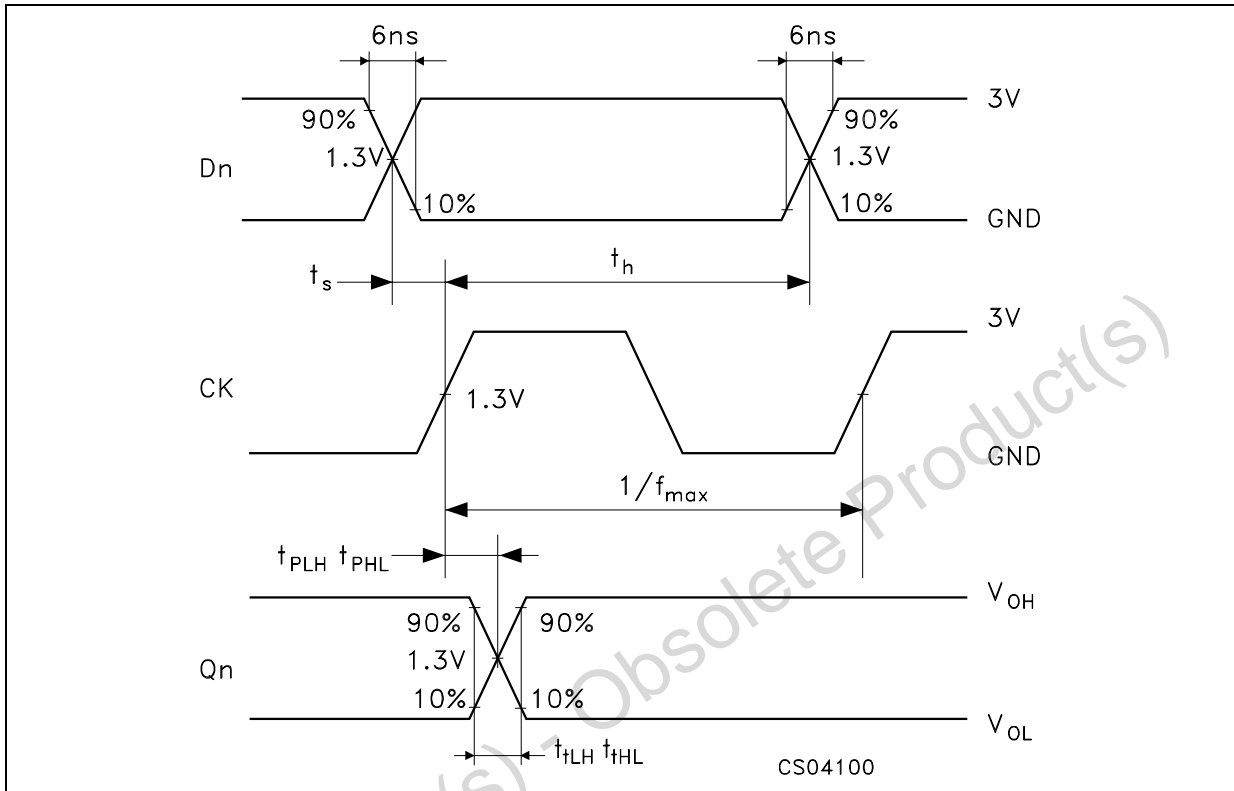

M74HCT374

WAVEFORM 2: OUTPUT ENABLE AND DISABLE TIMES (f=1MHz; 50% duty cycle)

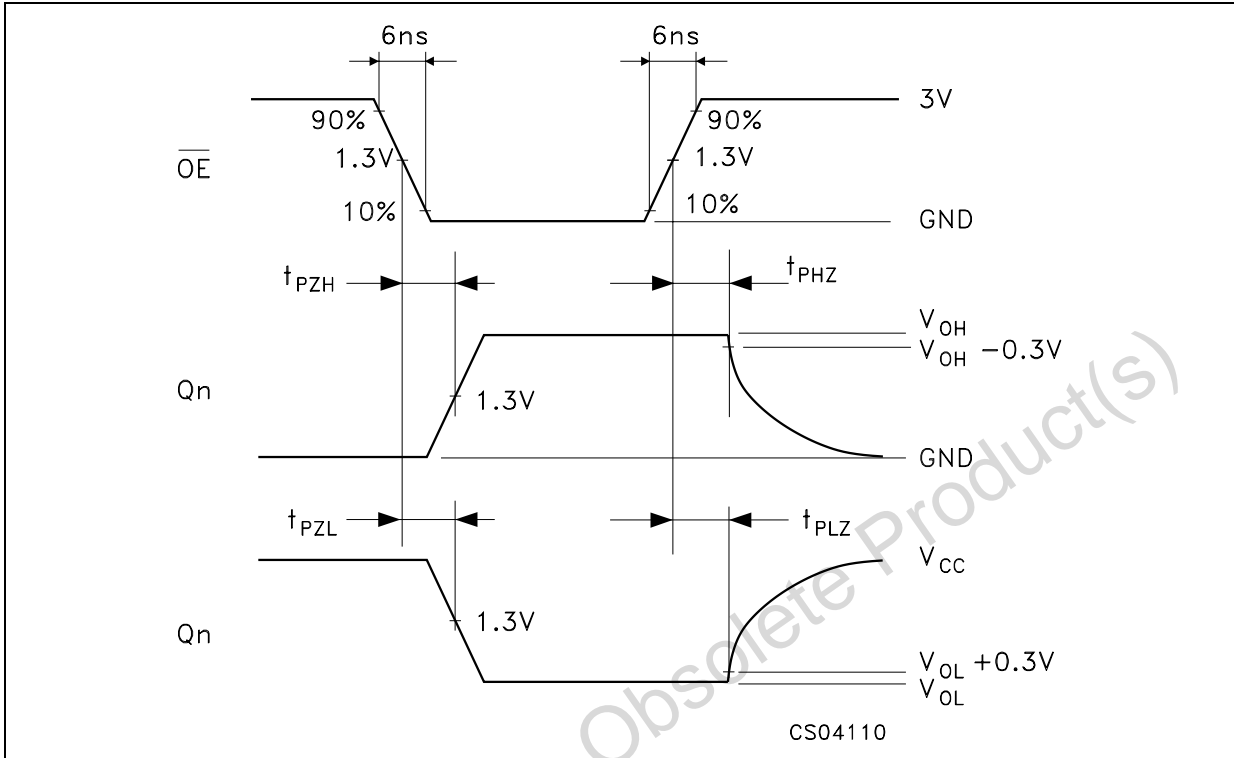

WAVEFORM 3: MINIMUM PULSE WIDTH (CK) (f=1MHz; 50% duty cycle)

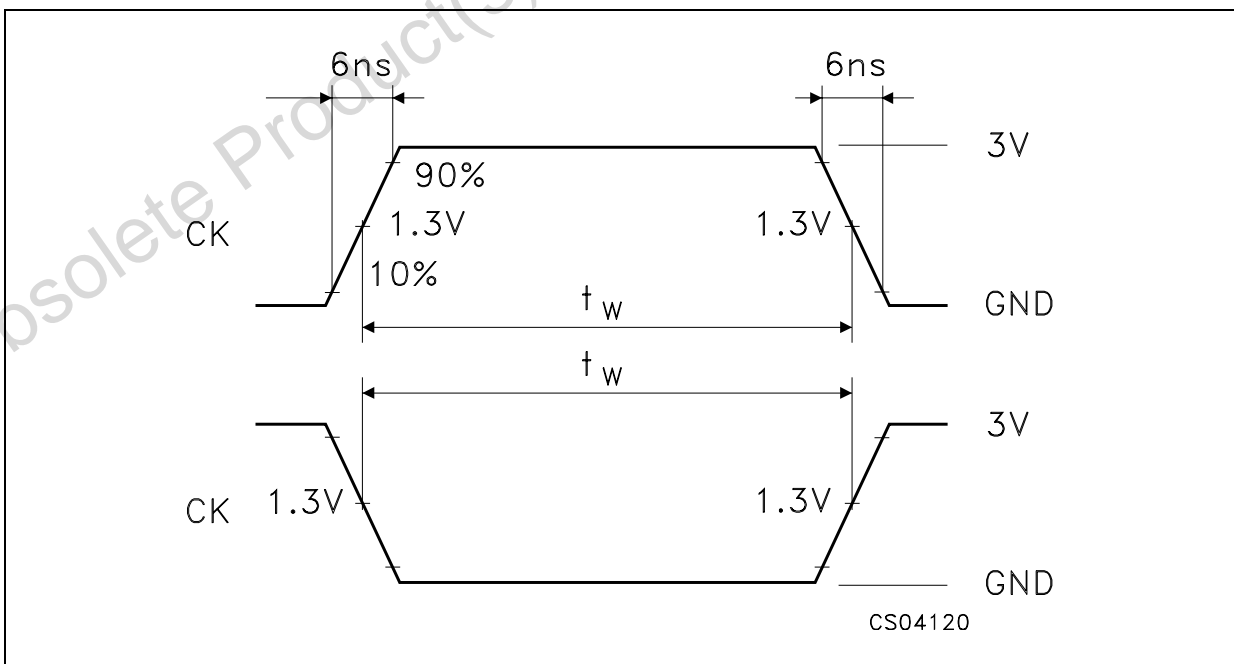

M74HCT374

Plastic DIP-20 (0.25) MECHANICAL DATA

DIM.	mm.			inch		
	MIN.	TYP.	MAX.	MIN.	TYP.	MAX.
a1	0.254			0.010		
B	1.39		1.65	0.055		0.065
b		0.45			0.018	
b1		0.25			0.010	
D			25.4			1.000
E		8.5			0.335	
e		2.54			0.100	
e3		22.86			0.900	
F			7.1			0.280
l			3.93			0.155
L		3.3			0.130	
Z			1.34			0.053

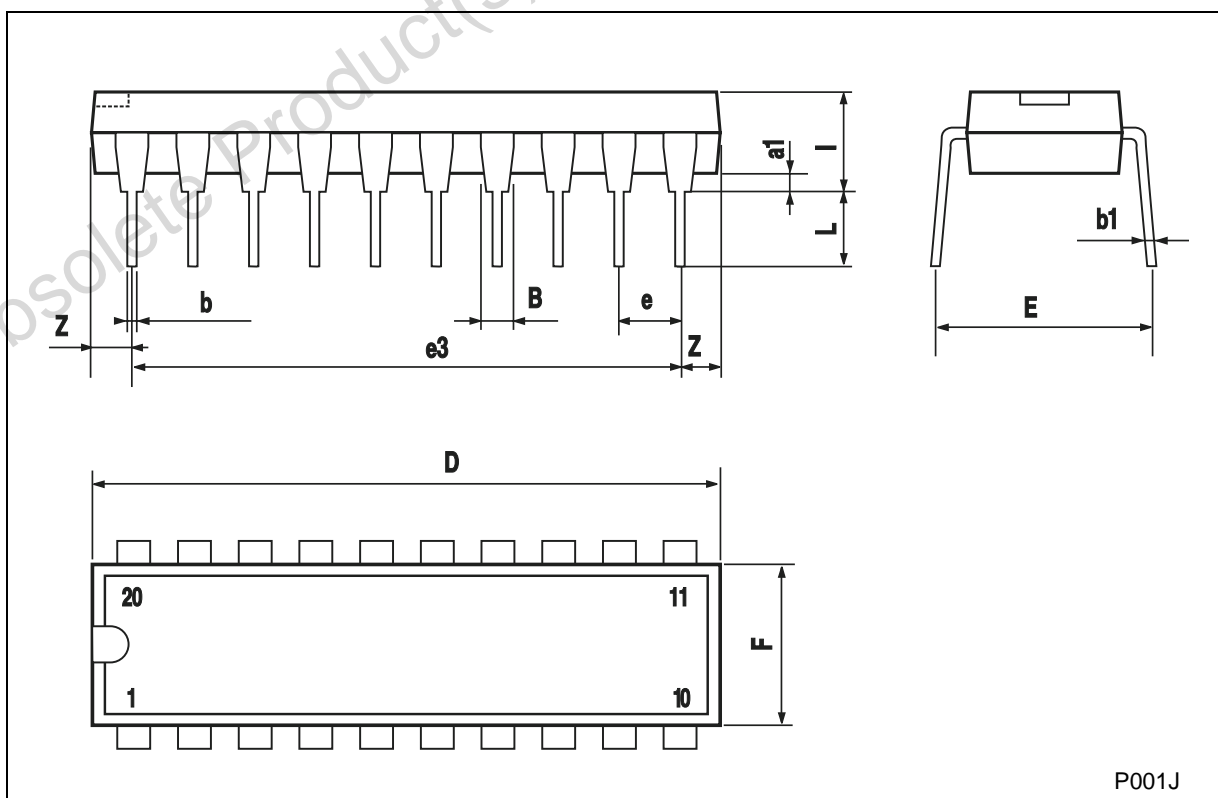

P001J

M74HCT374

SO-20 MECHANICAL DATA

DIM.	mm.			inch		
	MIN.	TYP.	MAX.	MIN.	TYP.	MAX.
A			2.65			0.104
a1	0.1		0.2	0.004		0.008
a2			2.45			0.096
b	0.35		0.49	0.014		0.019
b1	0.23		0.32	0.009		0.012
C		0.5			0.020	
c1	45° (typ.)					
D	12.60		13.00	0.496		0.512
E	10.00		10.65	0.393		0.419
e		1.27			0.050	
e3		11.43			0.450	
F	7.40		7.60	0.291		0.300
L	0.50		1.27	0.020		0.050
M			0.75			0.029
S	8° (max.)					

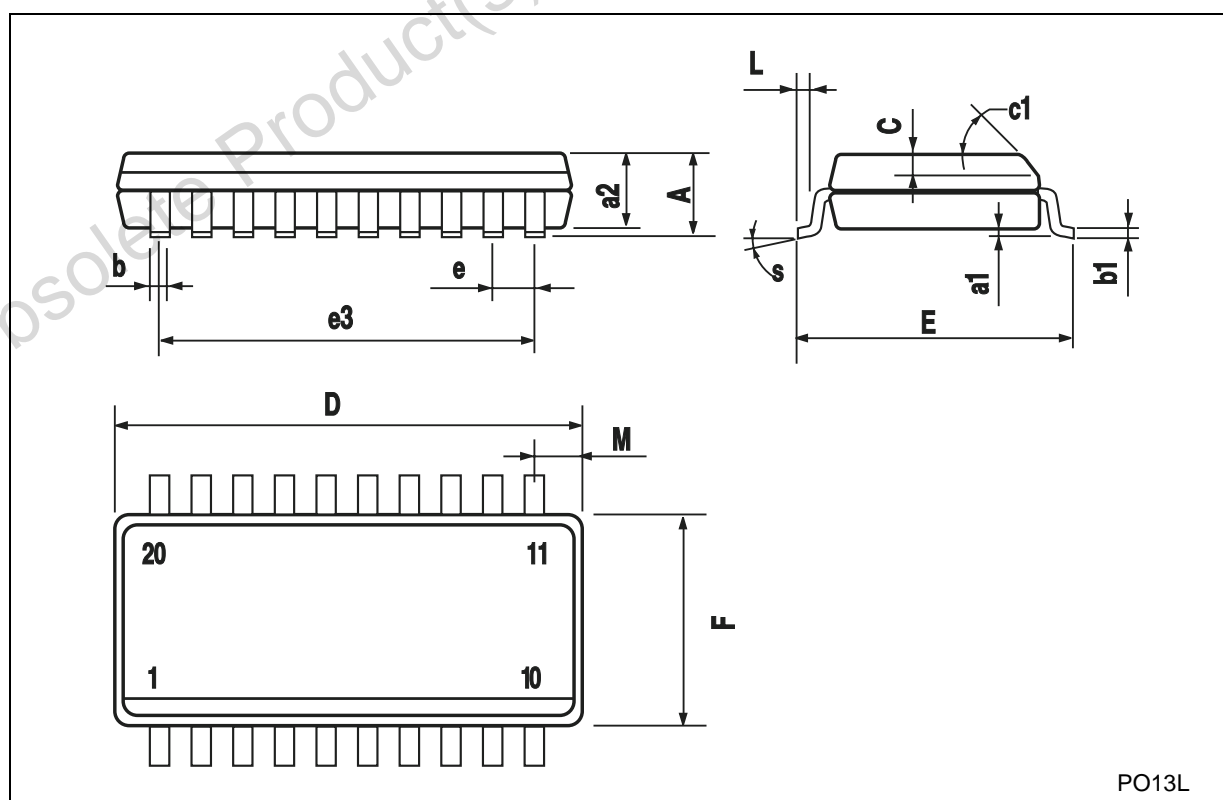

PO13L

M74HCT374

TSSOP20 MECHANICAL DATA

DIM.	mm.			inch		
	MIN.	TYP	MAX.	MIN.	TYP.	MAX.
A			1.2			0.047
A1	0.05		0.15	0.002	0.004	0.006
A2	0.8	1	1.05	0.031	0.039	0.041
b	0.19		0.30	0.007		0.012
c	0.09		0.20	0.004		0.0089
D	6.4	6.5	6.6	0.252	0.256	0.260
E	6.2	6.4	6.6	0.244	0.252	0.260
E1	4.3	4.4	4.48	0.169	0.173	0.176
e		0.65 BSC			0.0256 BSC	
K	0°		8°	0°		8°
L	0.45	0.60	0.75	0.018	0.024	0.030

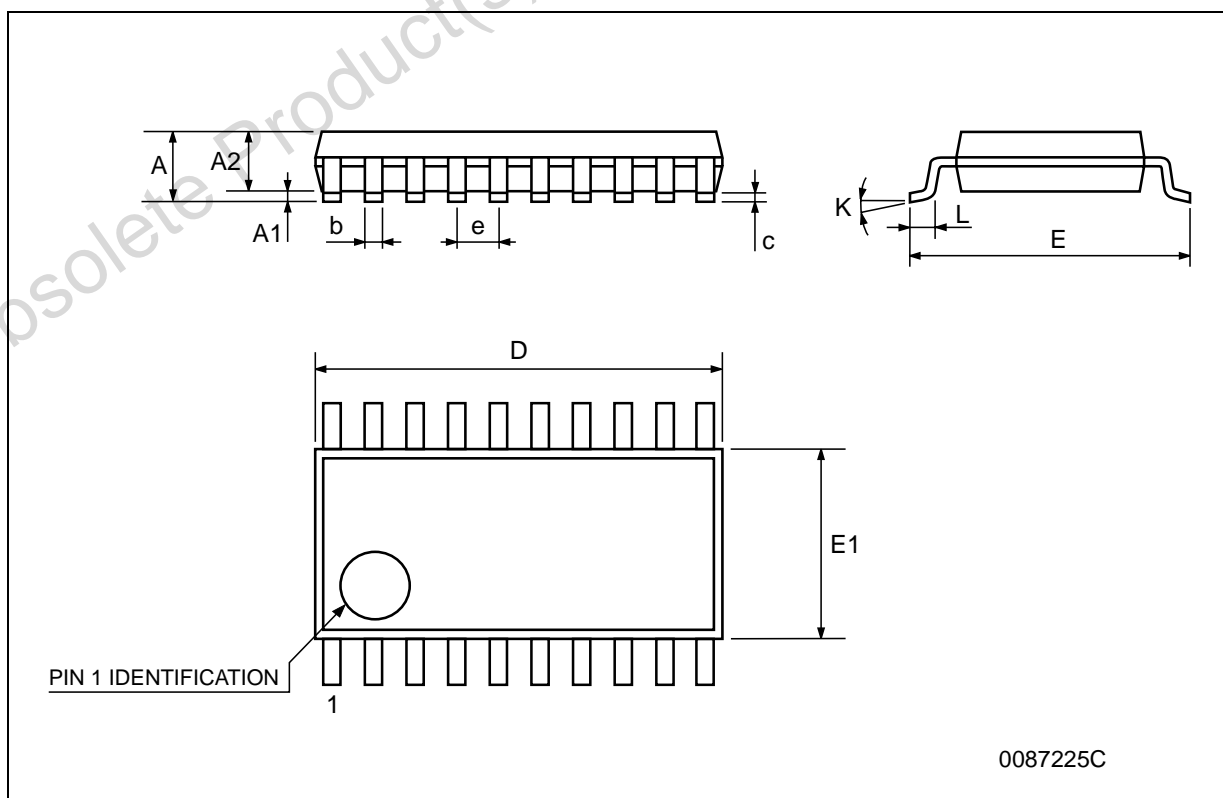

Obsolete Product(s) - Obsolete Product(s)

Information furnished is believed to be accurate and reliable. However, STMicroelectronics assumes no responsibility for the consequences of use of such information nor for any infringement of patents or other rights of third parties which may result from its use. No license is granted by implication or otherwise under any patent or patent rights of STMicroelectronics. Specifications mentioned in this publication are subject to change without notice. This publication supersedes and replaces all information previously supplied. STMicroelectronics products are not authorized for use as critical components in life support devices or systems without express written approval of STMicroelectronics.

© The ST logo is a registered trademark of STMicroelectronics

© 2000 STMicroelectronics - Printed in Italy - All Rights Reserved
STMicroelectronics GROUP OF COMPANIES

Australia - Brazil - China - Finland - France - Germany - Hong Kong - India - Italy - Japan - Malaysia - Malta - Morocco
Singapore - Spain - Sweden - Switzerland - United Kingdom

© <http://www.st.com>