

Excellent Integrated System Limited

Stocking Distributor

Click to view price, real time Inventory, Delivery & Lifecycle Information:

[STMicroelectronics](#)

[AVS12CB](#)

For any questions, you can email us directly:

sales@integrated-circuit.com



AVS12

AUTOMATIC VOLTAGE SWITCH (SMPS < 500W)

CONTROLLER

- 50/60Hz FULL COMPATIBILITY
- INTEGRATED VOLTAGE REGULATOR
- TRIGGERING PULSE TRAIN OF THE TRIAC
- PARASITIC FILTER
- LOW POWER CONSUMPTION

TRIAC

- HIGH EFFICIENCY AND SAFETY SWITCHING
- UNINSULATED PACKAGE : AVS12CB
- $V_{DRM} = \pm 600\text{ V}$
- $I_{T(RMS)} : 12\text{ A}$

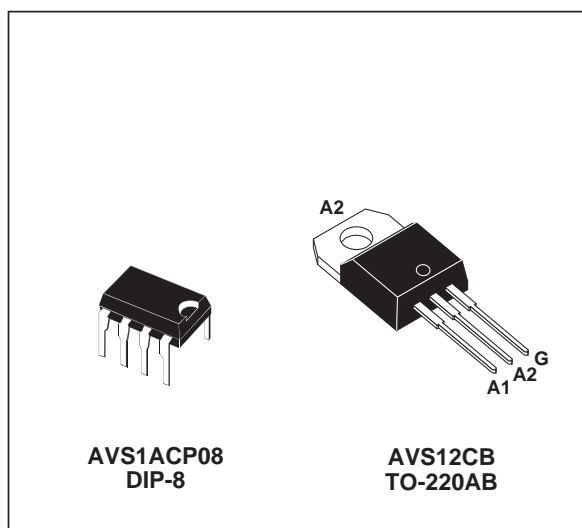

DESCRIPTION

The AVS12 kit is an automatic mains selector (110/220V AC) to be used in SMPS < 500 W. It is composed of 2 devices :

- The **Controller** is optimized for low consumption and high security triggering of the triac. When connected to V_{SS} , the **mode** input activates an additional **option**. If the main power drops from 220V to 110V, the triac control remains locked to the 220V mode and avoids any high voltage spike when the voltage is restored to 220V.
When connected to V_{DD} , the mode input deactivates this option.
- The **TRIAC** is specially designed for this application. An optimization between sensitivity and dynamic parameters of the triac gate highly reduces the losses of supply resistor and allows excellent immunity against disturbances.

PIN CONNECTION

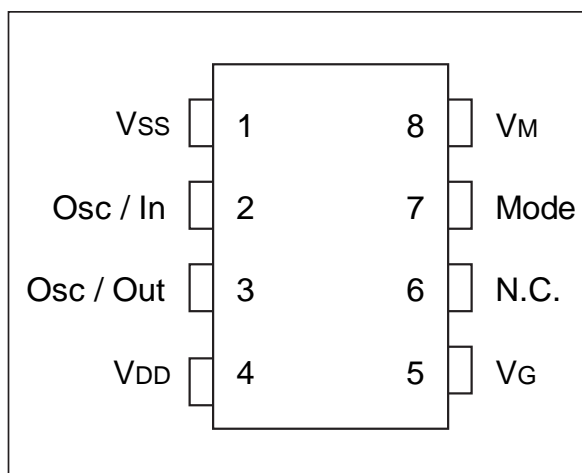

AVS12

BLOCK DIAGRAM

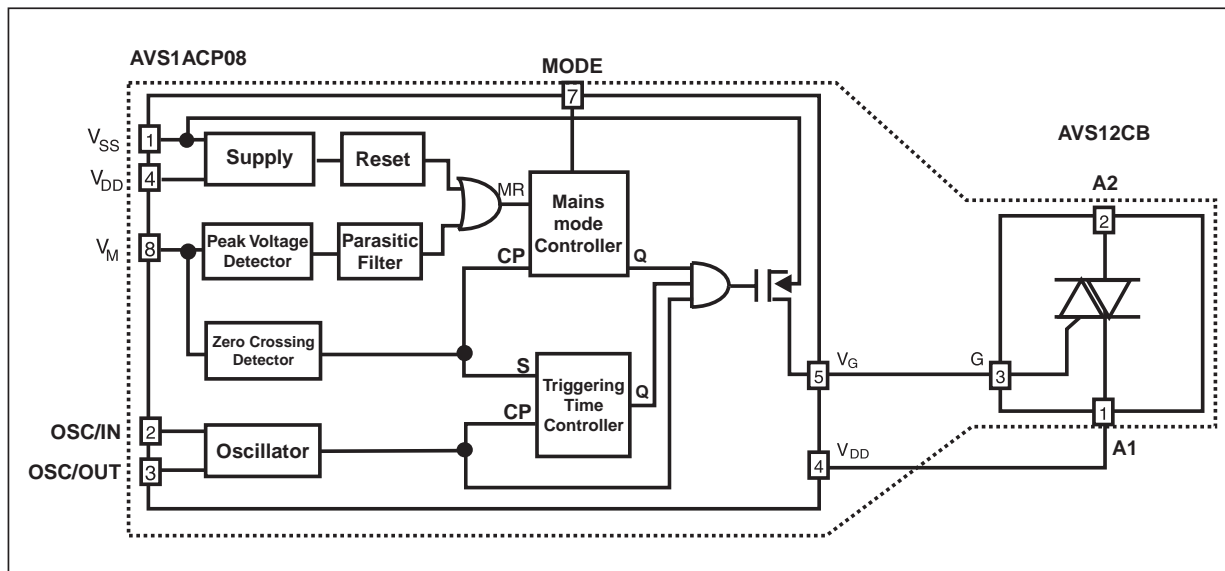

ABSOLUTE MAXIMUM RATINGS CONTROLLER AVS1ACP08

Symbol	Parameter	Value		Unit
		Min.	Max.	
V _{SS}	Supply voltage	-12	0.5	V
V _I / V _O	I / O voltage	V _{SS} -0.5	0.5	V
I _I / I _O	I / O current	-40	+40	mA
T _{stg}	Storage Temperature	-60	+150	°C
T _{oper}	Operating Temperature code "C"	0	+70	°C

TRIAC AVS12CB T_j = +25°C (unless otherwise specified)

Symbol	Parameter	Value	Unit
V _{DRM}	Repetitive peak off-state voltage (2)	± 600	V
I _{T(RMS)}	RMS on-state current (360° conduction angle)	T _C = 70°C 12	A
I _{TSM}	Non repetitive surge peak on-state current (T _j initial = 25°C)	t = 8.3ms t = 10ms 105 100	A
I ² t	I ² t value	t = 10ms 50	A ² s
di / dt	Critical rate of rise of on-state current (1)	Repetitive F = 50Hz 20 Non Repetitive 100	A/μs
dV/dt *	Linear slope up to 0.67 V _{DRM} Gate open	T _j = 110°C 50	V/μs
T _{stg} T _j	Storage Temperature Junction Temperature Range	- 40 + 150 0 + 125	°C

(1) Gate supply : I_G = 100mA - di/dt = 1A/μs
 (2) T_j = 110°C

* For either polarity of electrode A2 voltage with reference to electrode A1

AVS12

THERMAL RESISTANCE
 TRIAC AVS12CB

Symbol	Parameter	Value	Unit
Rth (j-a)	Junction to ambient	60	°C/W
Rth (j-c) DC	Junction to case for DC	3	°C/W
Rth (j-c) AC	Junction to case for 360° conduction angle (F = 50Hz)	2.3	°C/W

DC GENERAL ELECTRICAL CHARACTERISTICS
 TRIAC AVS12CB

Symbol	Parameter	Value		Unit
		Min.	Max.	
V _{GD}	V _D = V _{DRM} RL = 3.3kΩ Pulse duration > 20μs	T _j = 110°C	0.2	V
V _{TM} *	I _{TM} = 17A t _p = 10ms	T _j = 25°C	1.75	V
I _{DRM} *	V _{DRM} rated Gate open	T _j = 25°C	10	μA
		T _j = 110°C	500	

* For either polarity of electrode A2 voltage with reference to electrode A1

Fig. 1: Maximum RMS power dissipation versus RMS on-state current (F = 60Hz). (Curves are cut off by (di/dt)_c limitation)

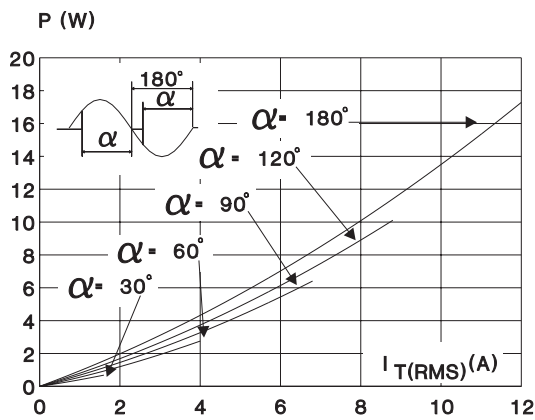
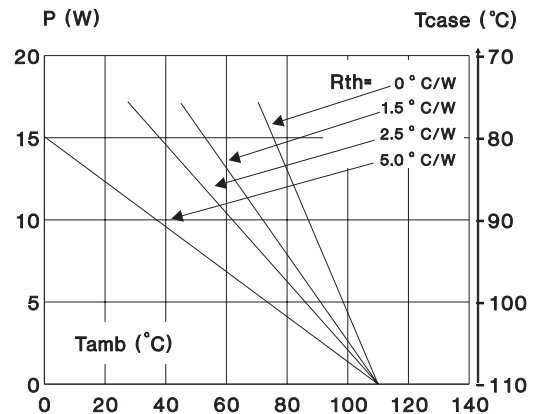

Fig. 2: Correlation between maximum mean power dissipation and maximum allowable temperature (Tamb and Tcase) for different thermal resistances heatsink + contact.



AVS12

Fig. 3: Non repetitive surge peak on-state current for a sinusoidal pulse with width: $t \leq 10\text{ms}$, and corresponding value of I^2t .

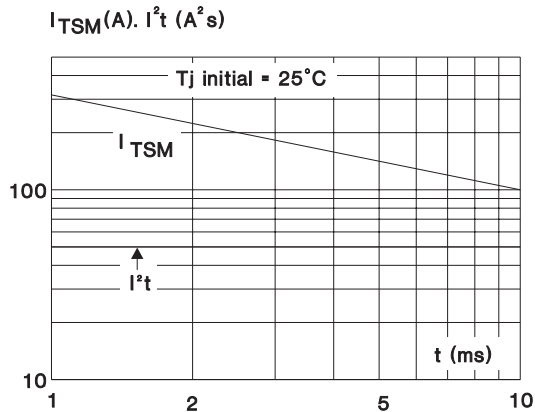
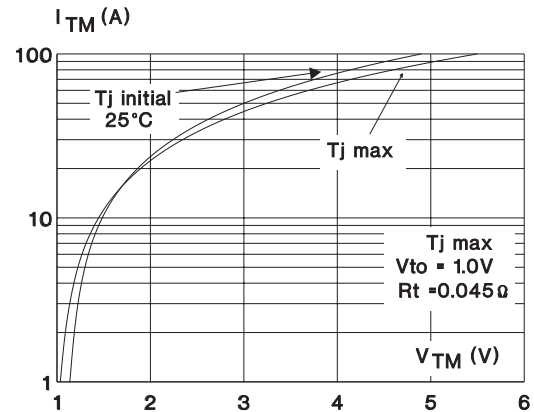

Fig. 4: On-state characteristics (maximum values).



DC GENERAL ELECTRICAL CHARACTERISTICS (continued)
 CONTROLLER AVS1ACP08 Toper = 25°C (unless otherwise specified)

Symbol	Parameter	Value			Unit
		Min.	Typ.	Max.	
V_{SS} (pin 1) (Vreg)	Shunt regulator	-10	-9	-8	V
I_{SS} (pin 1) (Vreg) (@ $V_{SS} = 9\text{V}$)	Supply current	0.4		30	mA
I_{SS} (pin 1) (@ triac gate non connected)	Quiescent current			0.7	mA
F (pin 3) (@ $R = 91\text{k}\Omega$) ($C = 100\text{pF}$)	Oscillator frequency	42	44	46	KHz
V_M (pin 8) V_{th} (3)	Peak voltage of detection high-threshold	4.08	4.25	4.42	V
V_M (pin 8) V_h (3)	Peak voltage of detection hysteresis	0.370	0.4	0.420	V
(1) V_M (pin 8) V_{th} (3)	Zero-crossing detection high-threshold	95	110	125	mV
V_M (pin 8) V_h (3)	Zero-crossing detection hysteresis	27	50	80	mV
(2) V_{razht} (4)	Power-on-reset activation threshold		$V_{reg} \times 0.89$		V
(2) V_{razlt} (4)	Power-down-reset activation threshold	3		6.5	V
Mode (pin 7)	V_{IL} (4) V_{IH} (4)	0.7 V_{reg}		0.3 V_{reg}	V

NOTE:

- (1) : This value gives a typical noise immunity on the zero-crossing detection of $110\text{mV} \times 1018/18 = 6.20\text{V}$ on the main supply
- (2) : See following diagram
- (3) : Voltage referred to V_{SS}
- (4) : Voltage referred to V_{DD}

AVS12

POWER-ON AND POWER-OFF RESET BEHAVIOUR

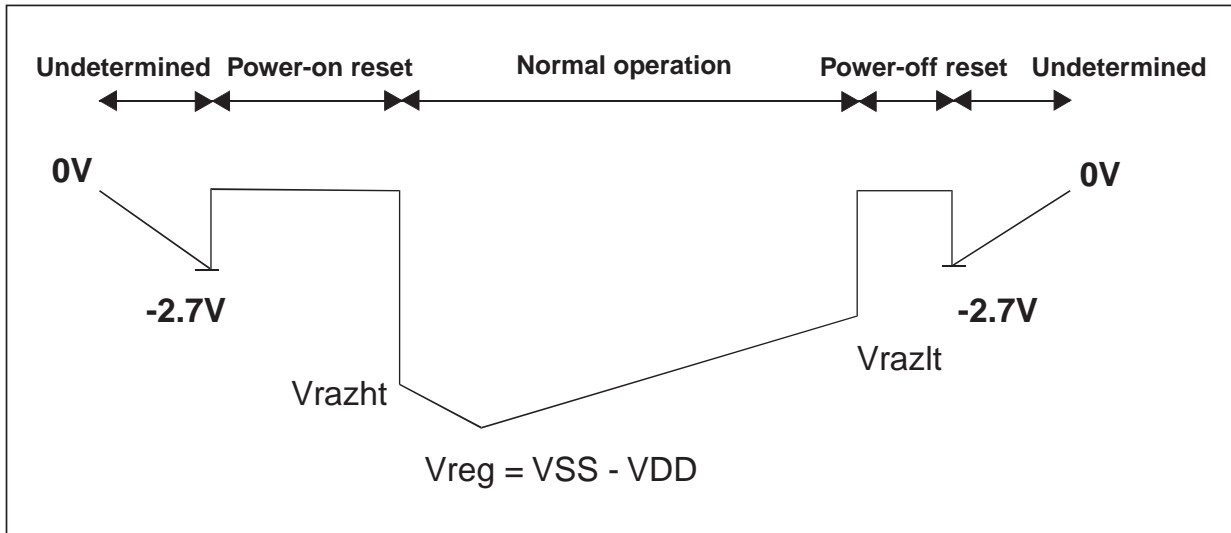

TYPICAL APPLICATION

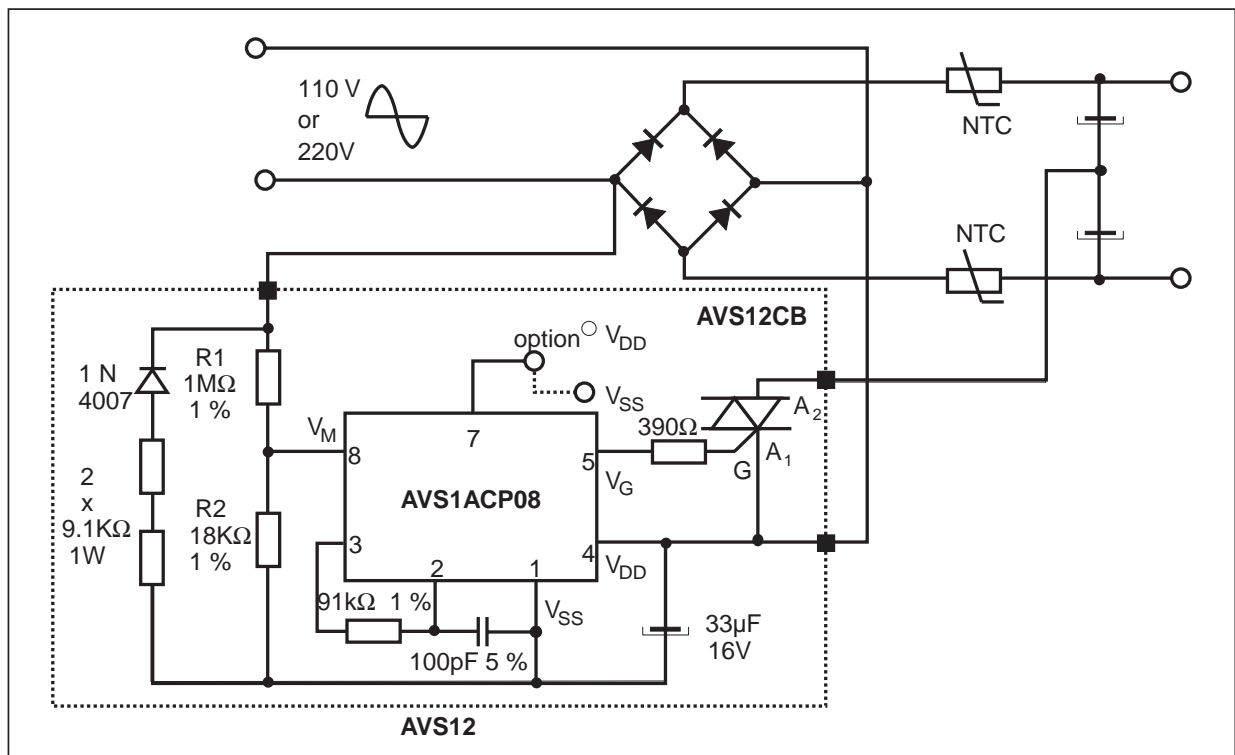

AVS12

ORDERING INFORMATION

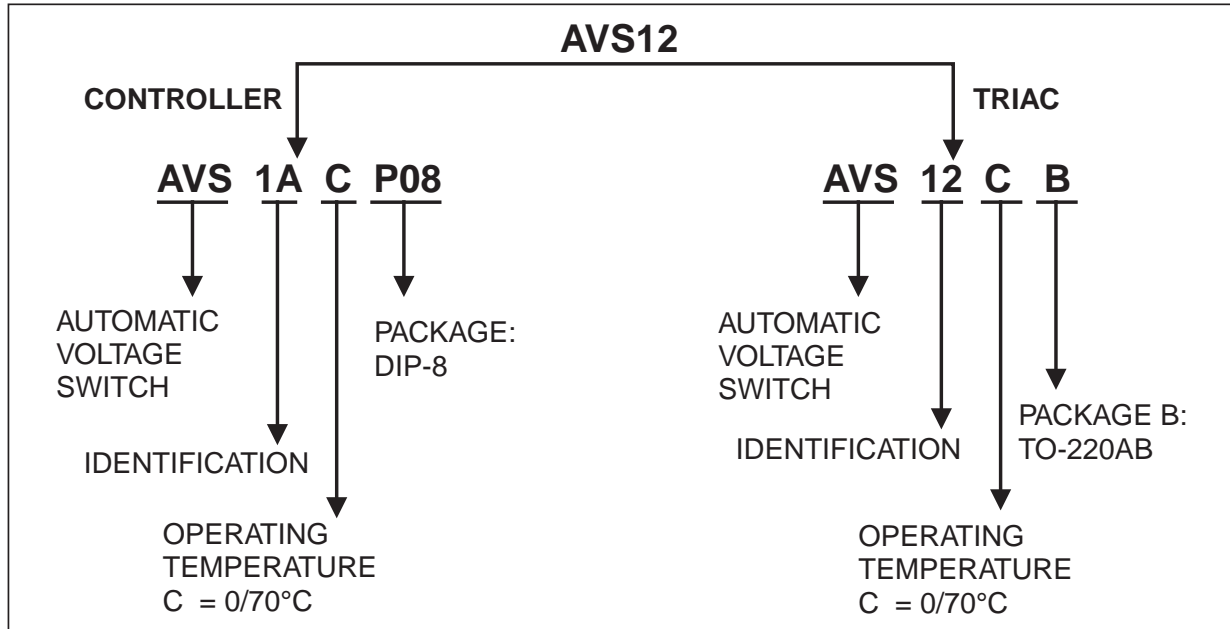

PACKAGE MECHANICAL DATA

DIP-8 Plastic (controller)

The mechanical drawings show the physical dimensions of the DIP-8 controller package. The top view shows dimensions a1, B, B1, b, e, e3, D, and Z. The side view shows dimensions L, F, E, and b1. The bottom view shows pin locations 1, 4, 5, and 8.

REF.	DIMENSIONS					
	Millimetres			Inches		
	Min.	Typ.	Max.	Min.	Typ.	Max.
a1	0.70			0.027		
B	1.39		1.65	0.055		0.065
B1	0.91		1.04	0.036		0.041
b		0.5			0.020	
b1	0.38		0.50	0.015		0.020
D			9.80			0.385
E		8.8			0.346	
e		2.54			0.100	
e3		7.62			0.300	
F			7.1			0.280
I			4.8			0.189
L		3.3			0.130	
Z	0.44		1.60	0.017		0.063

PACKAGE MECHANICAL DATA
 TO-220AB (Plastic) (Triac)

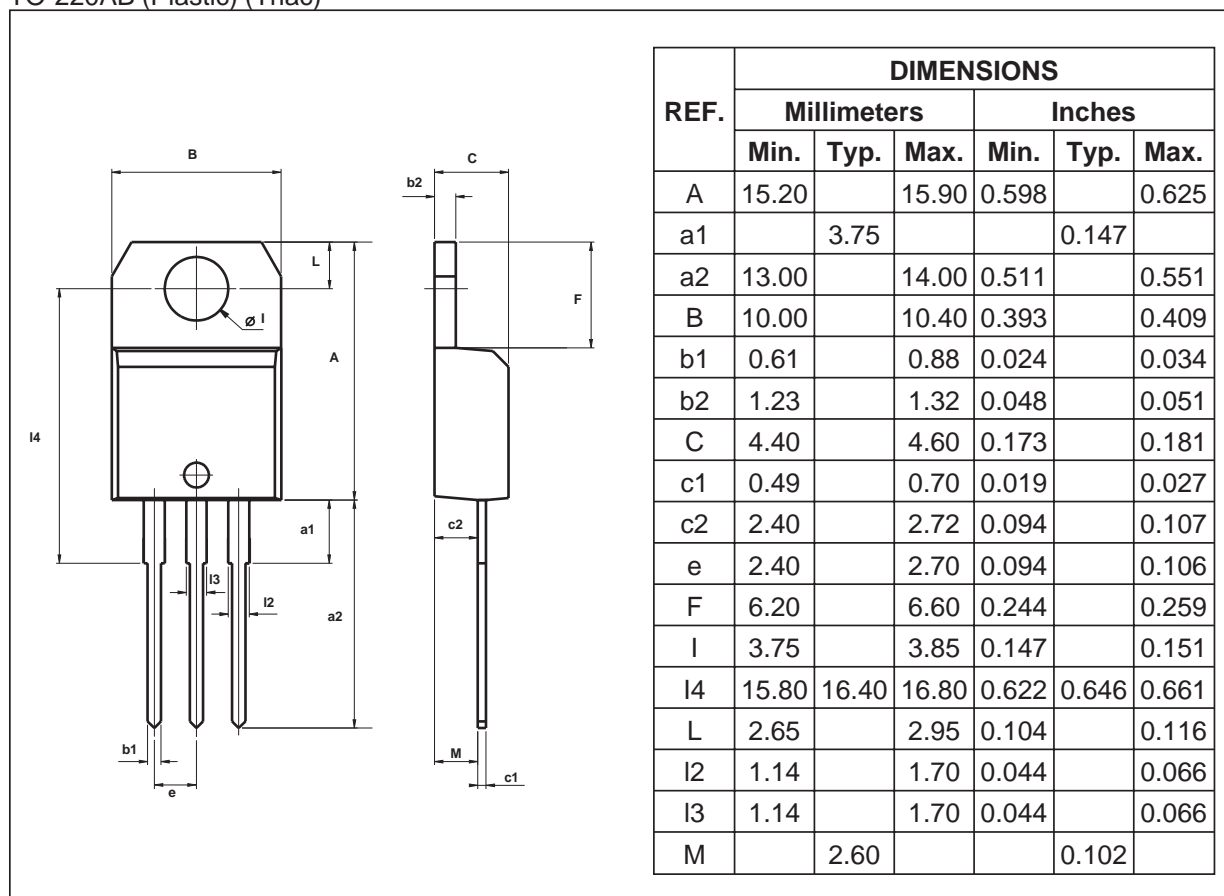

- Cooling method: C
- Recommended torque value: 0.8 m.N
- Maximum torque value: 1 m.N

OTHER INFORMATION

Part Number	Marking	Weight	Base Qty	Packing mode
AVS12CB	AVS12CB	2.3 g	1000	Tube
AVS1ACP08	AVS1ACP08	0.6 g	2000	Tube

Information furnished is believed to be accurate and reliable. However, STMicroelectronics assumes no responsibility for the consequences of use of such information nor for any infringement of patents or other rights of third parties which may result from its use. No license is granted by implication or otherwise under any patent or patent rights of STMicroelectronics. Specifications mentioned in this publication are subject to change without notice. This publication supersedes and replaces all information previously supplied. STMicroelectronics products are not authorized for use as critical components in life support devices or systems without express written approval of STMicroelectronics.

The ST logo is a registered trademark of STMicroelectronics
 © 2002 STMicroelectronics - Printed in Italy - All rights reserved.
 STMicroelectronics GROUP OF COMPANIES
 Australia - Brazil - Canada - China - Finland - France - Germany
 Hong Kong - India - Israel - Italy - Japan - Malaysia - Malta - Morocco - Singapore
 Spain - Sweden - Switzerland - United Kingdom - United States.

<http://www.st.com>