

## Excellent Integrated System Limited

Stocking Distributor

Click to view price, real time Inventory, Delivery & Lifecycle Information:

[Bel Fuse Inc.](#)  
[MQ 15](#)

For any questions, you can email us directly:  
[sales@integrated-circuit.com](mailto:sales@integrated-circuit.com)

RoHS

**bel**

MQ Apr2013D

**Type MQ**  
**Quick Acting Micro Fuse**

3 X 7 mm Size  
RoHS Compliant

**HF** MQ Series Fuse

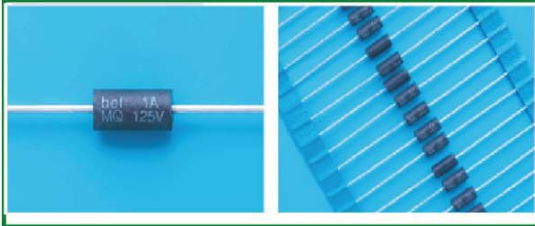

**Features**

- Quick Acting
- Small size
- Wide range of current rating from 100mA to 15A
- Wide operating temperature range
- RoHS compliant
- Halogen Free

**Applications**

- Notebook
- LCD monitor
- PC computer
- Office electronic equipment
- Industrial equipment
- Medical equipment
- POE, POE+
- LCD / LED monitor
- Power supply
- LCD / LED TV

HALOGEN FREE = **HF**

**Electrical Characteristics (UL / CSA /STD.248-14)**

Testing Current	Blow Time	
	Minimum	Maximum
100%	4 Hrs.	N/A
200%	N/A	5 Sec

**Safety Agency Approvals**

SAFETY AGENCY	SAFETY AGENCY CERTIFICATE	AMPERE RANGE / VOLT @ I.R.ABILITY
	LR39772	100mA - 15A / 125V @50A AC;300A DC
	E20624	

Specifications Subject to change without notice.

**Type MQ**  
**Quick Acting Micro Fuse**

3 X 7 mm Size  
 RoHS Compliant



MQ Apr2013D

**Electrical Specifications**

Catalog Number	Ampere Rating	Typical Cold Resistance (ohm)	Volt-drop @100% In (volt) Max.	Voltage Rating (V)	Interrupting Rating	Melting I2T <10 m Sec (A2 Sec)	Melting I2T @ 10 In (A2 Sec)	Maximum Power Dissipation (W)	Certification		
									SP	UL US	CE
MQ 100	100mA	13.8	2.70	125	100mA - 15A / 125V @50A AC;300A DC	0.0007	0.0006	0.35	Y	Y	Y
MQ 125	125mA	2.05	1.10	125		0.0012	0.0009	0.09	Y	Y	Y
MQ 150	150mA	1.56	1.00	125		0.0019	0.0015	0.10	Y	Y	Y
MQ 200	200mA	1.00	0.70	125		0.003	0.002	0.12	Y	Y	Y
MQ 250	250mA	0.52	0.45	125		0.005	0.004	0.14	Y	Y	Y
MQ 300	300mA	0.47	0.44	125		0.009	0.008	0.16	Y	Y	Y
MQ 375	375mA	0.41	0.43	125		0.013	0.012	0.18	Y	Y	Y
MQ 500	500mA	0.25	0.42	125		0.025	0.023	0.21	Y	Y	Y
MQ 750	750mA	0.152	0.41	125		0.062	0.056	0.27	Y	Y	Y
MQ 1	1 A	0.110	0.40	125		0.11	0.10	0.33	Y	Y	Y
MQ 1.5	1.5 A	0.064	0.28	125		0.29	0.25	0.42	Y	Y	Y
MQ 2	2 A	0.055	0.27	125		0.33	0.27	0.33	Y	Y	Y
MQ 2.5	2.5 A	0.038	0.26	125		0.59	0.50	0.40	Y	Y	Y
MQ 3	3 A	0.028	0.25	125		1.06	0.90	0.48	Y	Y	Y
MQ 3.5	3.5 A	0.027	0.24	125		1.4	1.2	0.53	Y	Y	Y
MQ 4	4 A	0.023	0.23	125	1.9	1.6	0.58	Y	Y	Y	
MQ 5	5 A	0.017	0.22	125	3.4	3.0	0.71	Y	Y	Y	
MQ 7	7 A	0.012	0.20	125	8	7	0.94	Y	Y	Y	
MQ 10	10 A	0.006	0.11	125	25	21	1.30	Y	Y	Y	
MQ 12	12 A	0.005	0.10	125	41	35	1.50	Y	Y	Y	
MQ 15	15 A	0.004	0.10	125	70	63	1.80	Y	Y	Y	

Consult manufacturer for other ratings

**Soldering Parameters**

I Wave Soldering Profile	
Wave Soldering Parameter	
Average ramp-up rate	200°C / second
Heating rate during preheat	typical 1 - 2°C / second Max. 4°C / second
Final preheat temperature	within 125°C of soldering temperature
Peak temperature Tp	260°C
Time within +0 °C / -5°C of actual peak temperature	10 seconds
Ramp-down rate	5 °C / second max.

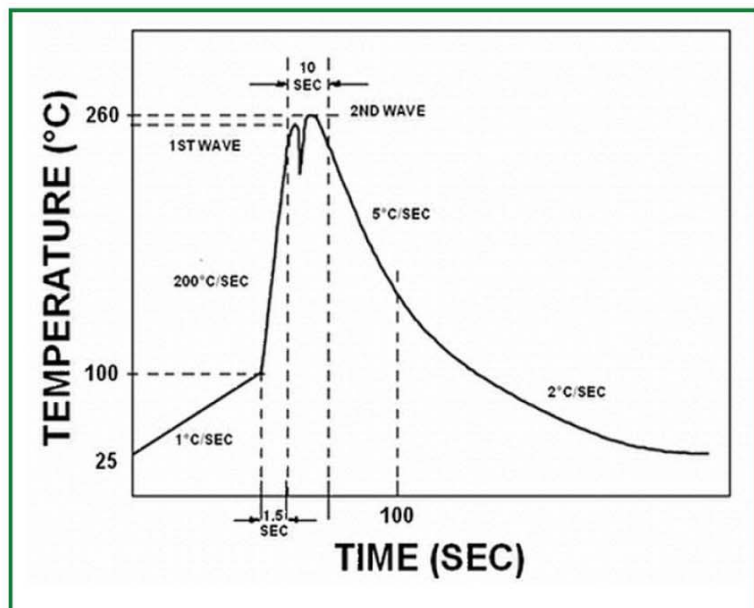



MQ Apr2013C

**Type MQ**  
**Quick Acting Micro Fuse**

RoHS Compliant



**Temperature Derating Curve**

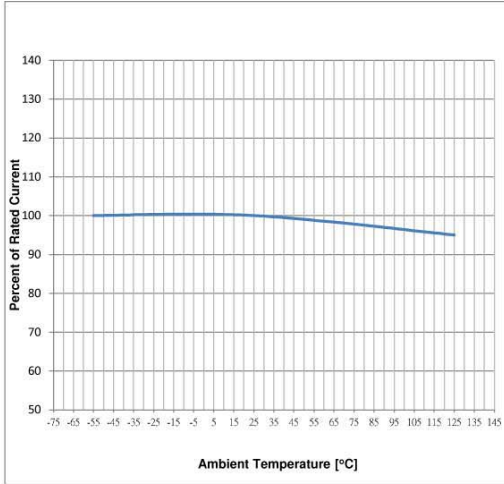

**Average Time Current Curve**

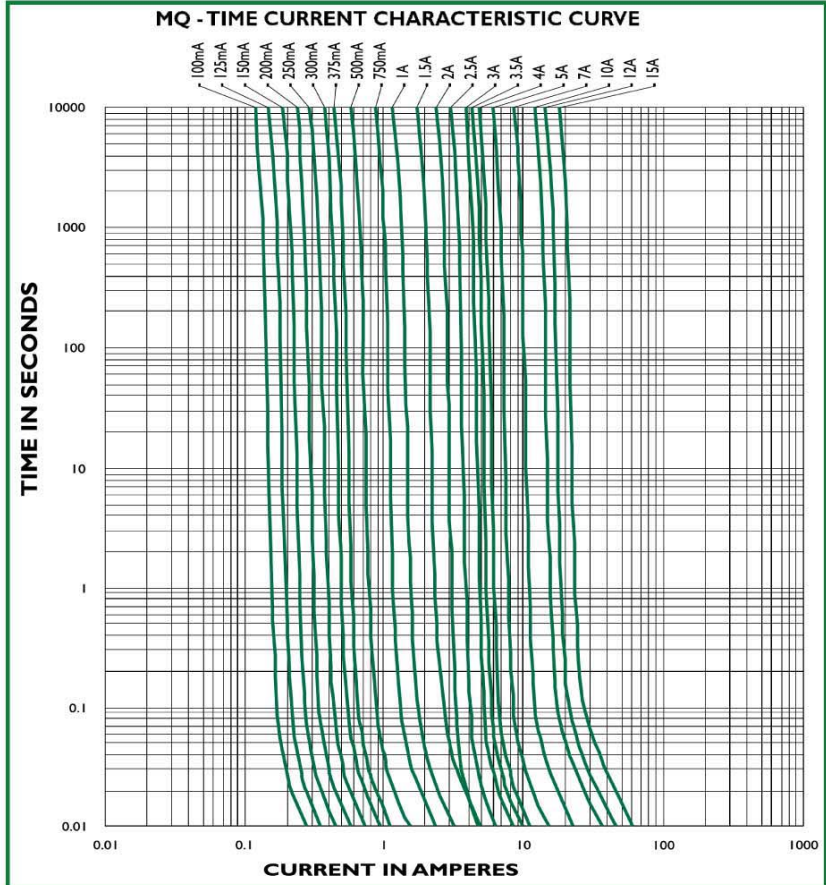

**Environmental Specifications**

<b>Shock Resistance</b>	MIL-STD-202G, Method 213B, Test Condition I (100 G's peak for 6 milliseconds; Sawtooth Waveform)
<b>Vibration Resistance</b>	MIL-STD-202G, Method 201A (10-55 Hz, 0.06 inch, total excursion).
<b>Salt Spray Resistance</b>	MIL-STD-202G, Method 101E, Test condition B (48 hrs).
<b>Insulation Resistance</b>	MIL-STD-202G, Method 302, Test Condition A (After Opening) 10,000 ohms minimum.
<b>Solderability</b>	MIL-STD-202G, Method 208H
<b>Resistance to Solder Heat</b>	MIL-STD-202G Method 210F, Test Condition B. (260°C, 10 sec)
<b>Thermal Shock</b>	MIL-STD-202G, Method 107G, Test Condition B (-65°C to +125°C).
<b>Operating Temperature</b>	-55°C to +125°C
<b>Moisture Resistance</b>	MIL-STD-202F, Method 106G



MQ Apr2013D

**Type MQ**  
**Quick Acting Micro Fuse**

3 x 7 mm Size  
 RoHS Compliant



**Physical Specifications**

<b>Materials</b>	Body : Molded with UL Recognized epoxy component plastic,UL 94-V0
	Lead Wire: Matte tin plated copper
<b>Marking</b>	On Fuse: "bel","MQ"," Current Rating"."125V" printed in white color
	On label:
	"bel", "MQ", "Current Rating", "Voltage Rating", "Interrupting Rating", "Appropriate Safety Logos" and "  ", "  " (China RoHS compliant).

**Fuse FGNO Explanation**

06XX-XXXXJ-XX, [XXXX]=Ampere Rating

Fraction	Decimal	Milliamps	Bel FGNO[XXXX]
1/32	.032	32	0032
1/25	.040	40	0040
1/20	.050	50	0050
1/16	.063	63	0063
8/100	.080	80	0080
1/10	.100	100	0100
1/8	.125	125	0125
15/100	.150	150	0150
	.160	160	0160
2/10	.200	200	0200
1/4	.250	250	0250
3/10	.300	300	0300
	.315	315	0315
3/8	.375	375	0375
4/10	.400	400	0400
1/2	.500	500	0500
6/10	.600	600	0600
	.630	630	0630
7/10	.700	700	0700
3/4	.750	750	0750
8/10	.800	800	0800

Fraction	Decimal	Amps	Bel FGNO[XXXX]
	1.0	1	1000
1-1/4	1.25	1.25	1250
1-1/2	1.50	1.5	1500
	1.60	1.6	1600
	2.0	2	2000
2-1/4	2.25	2.25	2250
2-1/2	2.5	2.5	2500
	3.0	3	3000
	3.15	3.15	3150
3-1/2	3.5	3.5	3500
	4.0	4	4000
	5.0	5	5000
	6.0	6	6000
	6.3	6.3	6300
	7.0	7	7000
7-1/2	7.5	7.5	7500
	8.0	8	8000
		10	9100
		12	9120
		15	9150
		20	9200
		25	9250
		30	9300

**Mechanical Dimensions**

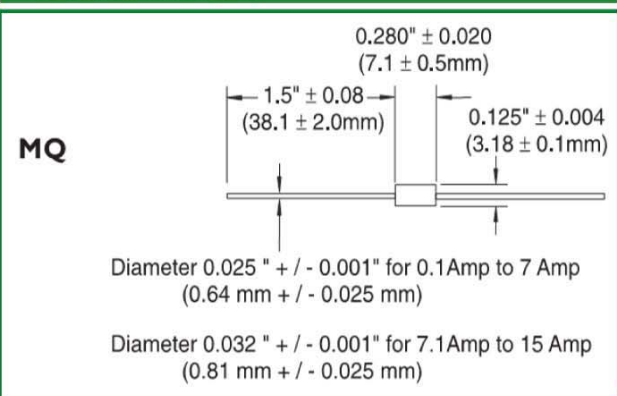

**Ordering Information**

0674 - XXXX - X X

**FUSE TYPE** \_\_\_\_\_  
 0674

**AMPERE RATING** \_\_\_\_\_  
 Refer to fuse FGNO explanation table

**VOLTAGE CODE** \_\_\_\_\_  
 0 = 125V

**PACKAGING CODE** \_\_\_\_\_  
 1 = BULK, 1K/Box  
 7 = Ammo Pack, 1K/Box  
 8 = T&R, 2500/Reel

**Packaging**

Packaging Option	Packaging Specification	Quantity	Packaging Code	Inside Tape Spacing
Bulk	N/A	1000	01	N/A
Bulk (Amon Package)	N/A	1000	07	N/A
Tape & Reel, 5 mm Pitch	EIA-296-F	2500	08	53

Specifications Subject to change without notice.

**CORPORATE OFFICE**

**Bel Fuse Inc.**  
 206 Van Vorst Street  
 Jersey City, NJ 07302  
 Tel 201-432-0463  
 Fax 201-432-9542  
 E-Mail: belfuse@belf.com  
 Website: www. belfuse.com

**FAR EAST OFFICE**

**Bel Fuse Ltd.**  
 8/F Luk Hop Industrial Building  
 8 Luk Hop Street  
 San Po Kong  
 Kowloon, Hong Kong  
 Tel 852-2328-5515  
 Fax 852-2352-3706

**EUROPE OFFICE**

**Bel Fuse Europe Ltd.**  
 Preston Technology Management Centre  
 Marsh Lane, Suite F15  
 Preston, Lancashire, PR1 8UQ  
 United Kingdom  
 Tel 44-1772-556601  
 Fax 44-1772-561008

**EUROPE**

**Bel Stewart GmbH**  
 Industriestrasse 20  
 61381 Friedrichsdorf  
 Germany  
 Tel 49-6172-9552-0  
 Fax 49-6172-9552-40