

Excellent Integrated System Limited

Stocking Distributor

Click to view price, real time Inventory, Delivery & Lifecycle Information:

[Schurter](#)
[6200.4312](#)

For any questions, you can email us directly:
sales@integrated-circuit.com

POWER ENTRY MODULES

6200/02/05, 6220

Dimensions Types 6200/02/05

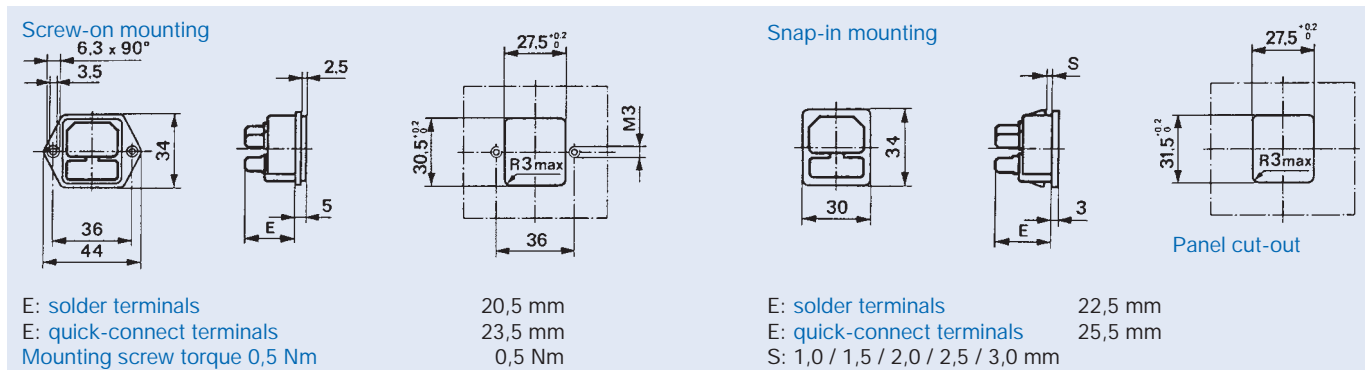

Dimensions Type 6220

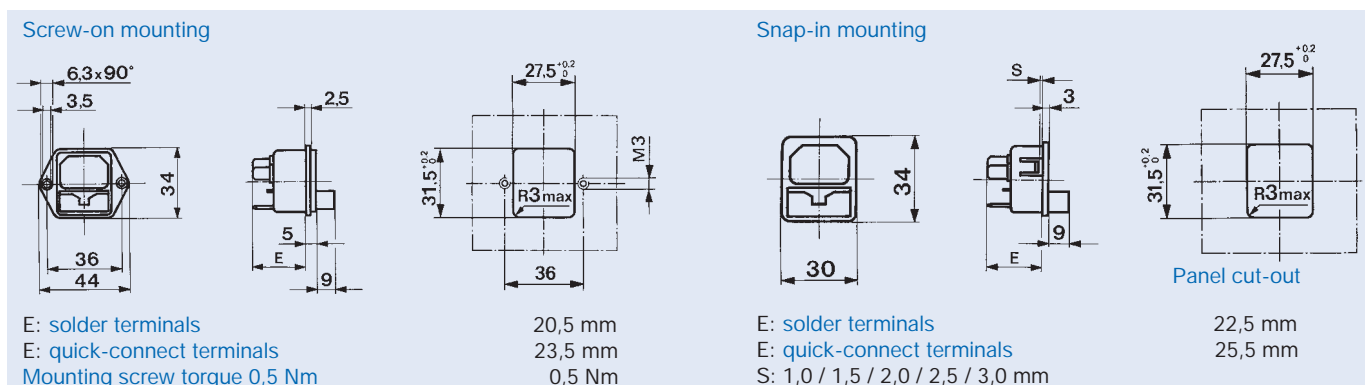

Derating curves for fuseholder

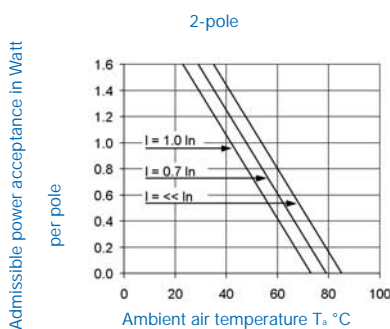
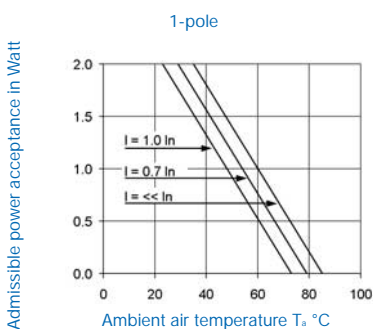

Diagrams

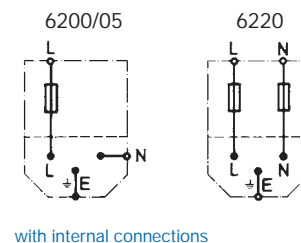

Order Numbers (socket and fuse drawer)

Types	Prot. class	Screw-on mounting		Snap-in mounting		Terminals	
		with internal connections	without internal connections	with internal connections	without internal connections	solder	quick-connect
6200	I	6200.2100		6200.41XX		•	
		6200.2200		6200.42XX			•
		6200.2300		6200.43XX			
6205	I		6205.2100		6205.41XX	•	
			6205.2200		6205.42XX		•
			6205.2300		6205.43XX		
6202	II	6202.2100				•	
		6202.2200					•
		6202.2300					
6220	I	6220.2100		6220.51XX		•	
		6220.2200		6220.52XX			•
		6220.2300		6220.53XX			

Types for rivet mounting on request. Therefore change in the order No. the 5th digit from "2" to "9" (e.g. 6220.9300)

"XX" panel thickness (s) in 1/10 mm. 10, 15, 20, 25, 30 (e.g. 6220.5210 for 1,0 mm)