

## Excellent Integrated System Limited

Stocking Distributor

Click to view price, real time Inventory, Delivery & Lifecycle Information:

[STMicroelectronics](#)  
[2N1613](#)

For any questions, you can email us directly:

[sales@integrated-circuit.com](mailto:sales@integrated-circuit.com)



**2N1613**  
**2N1711**

## SWITCHES AND UNIVERSAL AMPLIFIERS

### DESCRIPTION

The 2N1613 and 2N1711 are silicon planar epitaxial NPN transistors in Jedec TO-39 metal case. They are designed for use in high-performance amplifier, oscillator and switching circuits.

The 2N1711 is also used to advantage in amplifiers where low noise is an important factor.

 Products approved to CECC 50002-104 available on request.

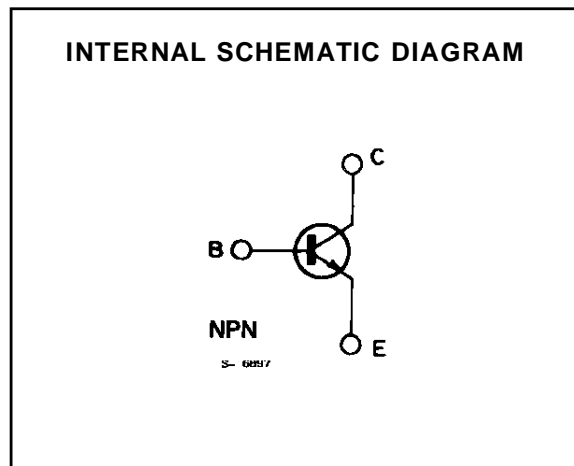
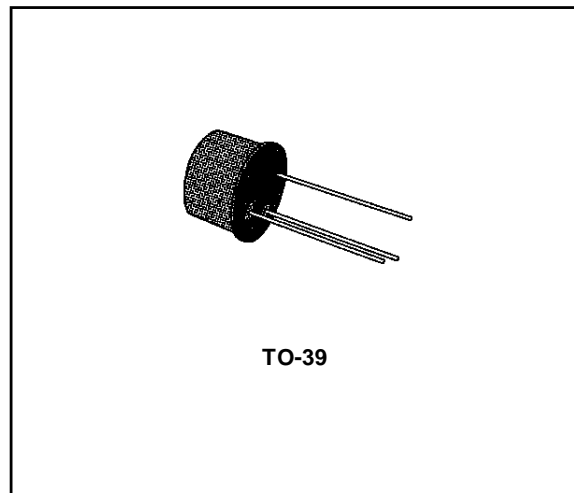

### ABSOLUTE MAXIMUM RATINGS

Symbol	Parameter	Value	Unit
$V_{CBO}$	Collector-base Voltage ( $I_E = 0$ )	75	V
$V_{CER}$	Collector-emitter Voltage ( $R_{BE} \leq 10 \Omega$ )	50	V
$V_{EBO}$	Emitter-base Voltage ( $I_C = 0$ )	7	V
$I_C$	Collector Current	500	mA
$P_{tot}$	Total Power Dissipation at $T_{amb} \leq 25 \text{ }^\circ\text{C}$	0.8	W
	at $T_{case} \leq 25 \text{ }^\circ\text{C}$	3	W
	at $T_{case} \leq 100 \text{ }^\circ\text{C}$	1.7	W
$T_{stg}, T_j$	Storage and Junction Temperature	- 65 to 200	$^\circ\text{C}$

## 2N1613-2N1711

### THERMAL DATA

$R_{th\ j-case}$	Thermal Resistance Junction-case	Max	58	°C/W
$R_{th\ j-amb}$	Thermal Resistance Junction-ambient	Max	219	°C/W

### ELECTRICAL CHARACTERISTICS ( $T_{amb} = 25\ ^\circ\text{C}$ unless otherwise specified)

Symbol	Parameter	Test Conditions	Min.	Typ.	Max.	Unit
$I_{CBO}$	Collector Cutoff Current ( $I_E = 0$ )	$V_{CB} = 60\ \text{V}$ $V_{CB} = 60\ \text{V}$ $T_{amb} = 150\ ^\circ\text{C}$			10 10	nA $\mu\text{A}$
$I_{EBO}$	Emitter Cutoff Current ( $I_C = 0$ )	$V_{EB} = 5\ \text{V}$ for <b>2N1613</b> for <b>2N1711</b>			10 5	nA nA
$V_{(BR)\ CBO}$	Collector-base Breakdown Voltage	$I_C = 0.1\ \text{mA}$	75			V
$V_{(BR)\ CER}^*$	Collector-emitter Breakdown Voltage ( $R_{BE} \leq 10\ \Omega$ )	$I_C = 10\ \text{mA}$	50			V
$V_{(BR)\ EBO}$	Emitter-base Breakdown Voltage ( $I_C = 0$ )	$I_E = 0.1\ \text{mA}$	7			V
$V_{CE\ (sat)}^*$	Collector-emitter Saturation Voltage	$I_C = 150\ \text{mA}$ $I_B = 15\ \text{mA}$		0.5	1.5	V
$V_{BE\ (sat)}^*$	Base-emitter Saturation Voltage	$I_C = 150\ \text{mA}$ $I_B = 15\ \text{mA}$		0.95	1.3	V
$h_{FE}^*$	DC Current Gain	for <b>2N1613</b> $I_C = 0.01\ \text{mA}$ $V_{CE} = 10\ \text{V}$ $I_C = 0.1\ \text{mA}$ $V_{CE} = 10\ \text{V}$ $I_C = 10\ \text{mA}$ $V_{CE} = 10\ \text{V}$ $I_C = 150\ \text{mA}$ $V_{CE} = 10\ \text{V}$ $I_C = 500\ \text{mA}$ $V_{CE} = 10\ \text{V}$ $I_C = 10\ \text{mA}$ $V_{CE} = 10\ \text{V}$ $T_{amb} = -55\ ^\circ\text{C}$	20 35 40 20 20	35 50 80 80 55 35	120	
$h_{FE}^*$	DC Current Gain	for <b>2N1711</b> $I_C = 0.01\ \text{mA}$ $V_{CE} = 10\ \text{V}$ $I_C = 0.1\ \text{mA}$ $V_{CE} = 10\ \text{V}$ $I_C = 10\ \text{mA}$ $V_{CE} = 10\ \text{V}$ $I_C = 150\ \text{mA}$ $V_{CE} = 10\ \text{V}$ $I_C = 500\ \text{mA}$ $V_{CE} = 10\ \text{V}$ $I_C = 10\ \text{mA}$ $V_{CE} = 10\ \text{V}$ $T_{amb} = 55\ ^\circ\text{C}$	20 35	60 80 130 130 75 65	300	
$h_{fe}$	Small Signal Current Gain	for <b>2N1613</b> $I_C = 1\ \text{mA}$ $V_{CE} = 10\ \text{V}$ $f = 1\ \text{kHz}$ for <b>2N1711</b> $I_C = 1\ \text{mA}$ $V_{CE} = 10\ \text{V}$ $f = 1\ \text{kHz}$	30 70	70 135	150 300	
$f_t$	Transition Frequency	$I_C = 50\ \text{mA}$ $V_{CE} = 10\ \text{V}$ $f = 20\ \text{MHz}$ for <b>2N1613</b> for <b>2N1711</b>	60 70	80 100		MHz MHz
$C_{EBO}$	Emitter-base Capacitance	$I_C = 0$ $V_{EB} = 0.5\ \text{V}$ $f = 1\ \text{MHz}$		50	80	pF
$C_{CBO}$	Collector-base Capacitance	$I_E = 0$ $V_{CB} = 10\ \text{V}$ $f = 1\ \text{MHz}$		18	25	pF

\* Pulsed : pulse duration = 300  $\mu\text{s}$ , duty cycle = 1 %.

**2N1613-2N1711**
**ELECTRICAL CHARACTERISTICS** (continued)

Symbol	Parameter	Test Conditions	Min.	Typ.	Max.	Unit
NF	Noise Figure	$I_C = 0.3 \text{ mA}$ $R_g = 510 \ \Omega$				
		$V_{CE} = 10 \text{ V}$ $f = 1 \text{ kHz}$ for <b>2N1613</b> for <b>2N1711</b>		6 3.5	12 8	dB dB
$h_{ie}$	Input Impedance	$I_C = 1 \text{ mA}$ $f = 1 \text{ KHz}$				
		$V_{CE} = 5 \text{ V}$ for <b>2N1613</b> for <b>2N1711</b>		2.2 4.4		k $\Omega$ k $\Omega$
$h_{re}$	Reverse Voltage Ratio	$I_C = 1 \text{ mA}$ $f = 1 \text{ kHz}$				
		$V_{CE} = 5 \text{ V}$ for <b>2N1613</b> for <b>2N1711</b>		$3.6 \times 10^{-4}$ $7.3 \times 10^{-4}$		
$h_{oe}$	Output Admittance	$I_C = 1 \text{ mA}$ $f = 1 \text{ kHz}$				
		$V_{CE} = 5 \text{ V}$ for <b>2N1613</b> for <b>2N1711</b>		12.5 23.8		$\mu\text{S}$ $\mu\text{S}$

\* Pulsed : pulse duration = 300  $\mu\text{s}$ , duty cycle = 1 %.

**2N1613-2N1711**

**TO39 MECHANICAL DATA**

DIM.	mm			inch		
	MIN.	TYP.	MAX.	MIN.	TYP.	MAX.
A	12.7			0.500		
B			0.49			0.019
D			6.6			0.260
E			8.5			0.334
F			9.4			0.370
G	5.08			0.200		
H			1.2			0.047
I			0.9			0.035
L	45° (typ.)					

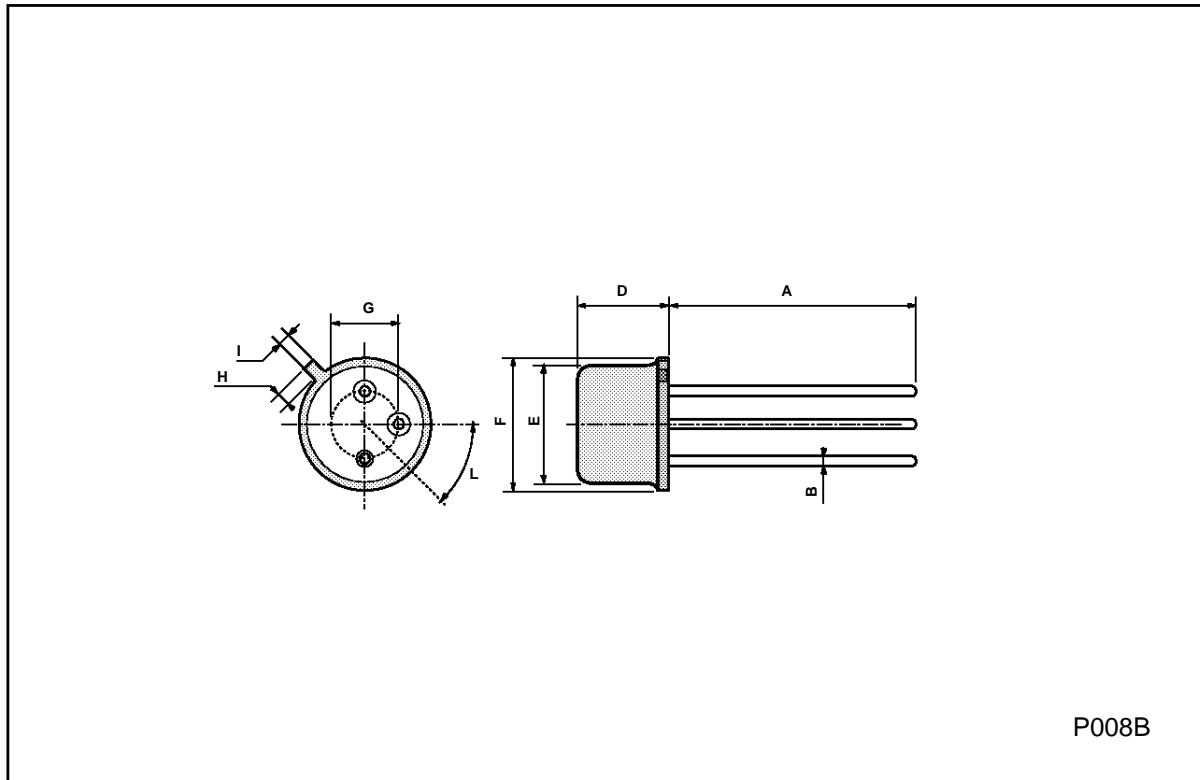

P008B

---

**2N1613-2N1711**

Information furnished is believed to be accurate and reliable. However, SGS-THOMSON Microelectronics assumes no responsibility for the consequences of use of such information nor for any infringement of patents or other rights of third parties which may result from its use. No license is granted by implication or otherwise under any patent or patent rights of SGS-THOMSON Microelectronics. Specifications mentioned in this publication are subject to change without notice. This publication supersedes and replaces all information previously supplied. SGS-THOMSON Microelectronics products are not authorized for use as critical components in life support devices or systems without express written approval of SGS-THOMSON Microelectronics.

© 1994 SGS-THOMSON Microelectronics - All Rights Reserved

SGS-THOMSON Microelectronics GROUP OF COMPANIES

Australia - Brazil - France - Germany - Hong Kong - Italy - Japan - Korea - Malaysia - Malta - Morocco - The Netherlands - Singapore - Spain - Sweden - Switzerland - Taiwan - Thailand - United Kingdom - U.S.A