

## Excellent Integrated System Limited

Stocking Distributor

Click to view price, real time Inventory, Delivery & Lifecycle Information:

[STMicroelectronics](#)  
[STD30PF03LT4](#)

For any questions, you can email us directly:

[sales@integrated-circuit.com](mailto:sales@integrated-circuit.com)



# STD30PF03LT4 STD30PF03L-1

P-channel 30 V - 0.025 Ω - 24 A - DPAK / IPAK  
STripFET™ II Power MOSFET

## Features

Type	V <sub>DSS</sub>	R <sub>DS(on)</sub> max	I <sub>D</sub>
STD30PF03LT4	30 V	< 0.028 Ω	24 A
STD30PF03L-1	30 V	< 0.028 Ω	24 A

- Standard outline for easy automated surface mount assembly
- Low threshold device
- Low gate charge

## Application

- Switching applications

## Description

This Power MOSFET is the latest development of STMicroelectronics unique “single feature size” strip-based process. The resulting transistor shows extremely high packing density for low on-resistance and low gate charge.

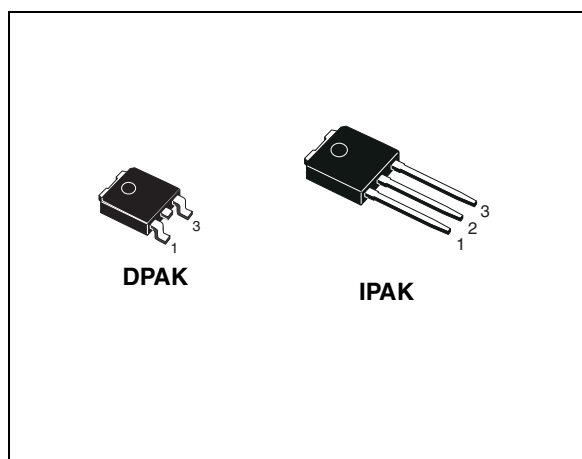


Figure 1. Internal schematic diagram

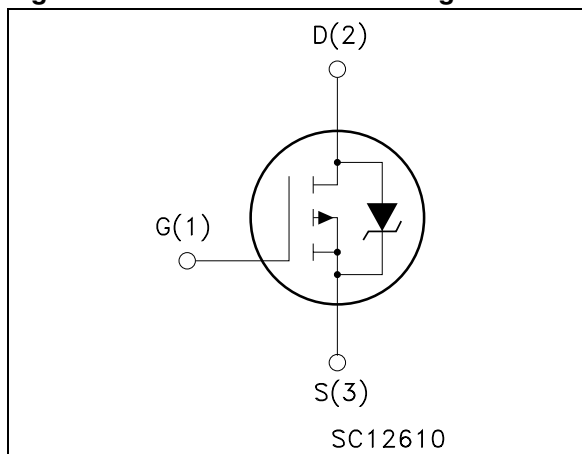


Table 1. Device summary

Order codes	Marking	Package	Packaging
STD30PF03LT4	D30PF03L	DPAK	Tape & reel
STD30PF03L-1	D30PF03L	IPAK	Tube

Electrical ratings

STD30PF03LT4 - STD30PF03L-1

# 1 Electrical ratings

**Table 2. Absolute maximum ratings**

Symbol	Parameter	Value	Unit
$V_{DS}$	Drain-source voltage ( $V_{GS}=0$ )	30	V
$V_{GS}$	Gate-source voltage	$\pm 16$	V
$I_D^{(1)}$	Drain current (continuous) at $T_C = 25\text{ }^\circ\text{C}$	24	A
$I_D^{(1)}$	Drain current (continuous) at $T_C = 100\text{ }^\circ\text{C}$	24	A
$I_{DM}^{(2)}$	Drain current (pulsed)	96	A
$P_{TOT}$	Total dissipation at $T_C=25\text{ }^\circ\text{C}$	70	W
	Derating factor	0.47	W/ $^\circ\text{C}$
$E_{AS}^{(3)}$	Single pulse avalanche energy	850	mJ
$T_{stg}$	Storage temperature	-55 to 175	$^\circ\text{C}$
$T_j$	Max. operating junction temperature	175	$^\circ\text{C}$

1. Current limited by wire bonding
2. Pulse width limited by safe operating area
3. Starting  $T_j = 25\text{ }^\circ\text{C}$ ,  $I_D = 12\text{ A}$ ,  $V_{DD} = 15\text{ V}$

**Table 3. Thermal data**

Symbol	Parameter	Max value		Unit
		DPAK	IPAK	
$R_{thj-case}$	Thermal resistance junction-case max	2.14		$^\circ\text{C/W}$
$R_{thj-amb}$	Thermal resistance junction-ambient max	--	100	$^\circ\text{C/W}$
$R_{thj-pcb}$	Thermal resistance junction-pcb max	50 <sup>(1)</sup>	--	$^\circ\text{C/W}$
$T_l$	Maximum lead temperature for soldering purpose	--	275	$^\circ\text{C/W}$

1. When mounted on FR-4 board of 1 inch<sup>2</sup>.

Note: For the p-channel Power MOSFET actual polarity of voltages and current has to be reversed

STD30PF03LT4 - STD30PF03L-1

Electrical characteristics

## 2 Electrical characteristics

(T<sub>CASE</sub>=25 °C unless otherwise specified)

**Table 4. On/off states**

Symbol	Parameter	Test conditions	Min.	Typ.	Max.	Unit
V <sub>(BR)DSS</sub>	Drain-source breakdown voltage	I <sub>D</sub> = 250 μA, V <sub>GS</sub> = 0	30			V
I <sub>DSS</sub>	Zero gate voltage drain current (V <sub>GS</sub> = 0)	V <sub>DS</sub> = Max rating V <sub>DS</sub> = Max rating, T <sub>c</sub> = 100 °C			1 10	μA μA
I <sub>GSS</sub>	Gate body leakage current (V <sub>DS</sub> = 0)	V <sub>GS</sub> = ±16 V			±100	nA
V <sub>GS(th)</sub>	Gate threshold voltage	V <sub>DS</sub> = V <sub>GS</sub> , I <sub>D</sub> = 250 μA	1			V
R <sub>DS(on)</sub>	Static drain-source on resistance	V <sub>GS</sub> = 10 V, I <sub>D</sub> = 12 A V <sub>GS</sub> = 5 V, I <sub>D</sub> = 12 A		0.025 0.032	0.028 0.040	Ω Ω

**Table 5. Dynamic**

Symbol	Parameter	Test conditions	Min.	Typ.	Max.	Unit
g <sub>fs</sub> <sup>(1)</sup>	Forward transconductance	V <sub>DS</sub> = 15 V, I <sub>D</sub> = 12 A		23		S
C <sub>iss</sub> C <sub>oss</sub> C <sub>rss</sub>	Input capacitance Output capacitance Reverse transfer capacitance	V <sub>DS</sub> = 25 V, f = 1 MHz, V <sub>GS</sub> = 0		1670 345 120		pF pF pF
Q <sub>g</sub> Q <sub>gs</sub> Q <sub>gd</sub>	Total gate charge Gate-source charge Gate-drain charge	V <sub>DD</sub> = 15 V, I <sub>D</sub> = 24 A V <sub>GS</sub> = 5 V <i>Figure 15</i>		18.6 5.5 11	28	nC nC nC

1. Pulsed: pulse duration = 300 μs, duty cycle 1.5%

Note: For the p-channel Power MOSFET actual polarity of voltages and current has to be reversed

**Electrical characteristics**
**STD30PF03LT4 - STD30PF03L-1**
**Table 6. Switching times**

Symbol	Parameter	Test conditions	Min	Typ	Max	Unit
$t_{d(on)}$	Turn-on delay time	$V_{DD}=25\text{ V}$ , $I_D=24\text{ A}$ , $R_G=4.7\ \Omega$ , $V_{GS}=5\text{ V}$ <i>Figure 14</i>		64		ns
$t_r$	Rise time			122		ns
$t_{d(off)}$	Turn-off delay time			36		ns
$t_f$	Fall time			26		ns

**Table 7. Source drain diode**

Symbol	Parameter	Test conditions	Min	Typ	Max	Unit	
$I_{SD}$	Source-drain current				24	A	
$I_{SDM}^{(1)}$	Source-drain current (pulsed)				96	A	
$V_{SD}^{(2)}$	Forward on voltage	$I_{SD} = 12\text{ A}$ , $V_{GS}=0$			1.3	V	
$t_{rr}$	Reverse recovery time	$I_{SD}=24\text{ A}$ , $di/dt = 100\text{ A}/\mu\text{s}$ , $V_{DD}=50\text{ V}$ , $T_j=150\text{ }^\circ\text{C}$ <i>Figure 16</i>		40		ns	
$Q_{rr}$	Reverse recovery charge				52		$\mu\text{C}$
$I_{RRM}$	Reverse recovery current				2.6		A

1. Pulse width limited by safe operating area
2. Pulsed: pulse duration = 300  $\mu\text{s}$ , duty cycle 1.5%

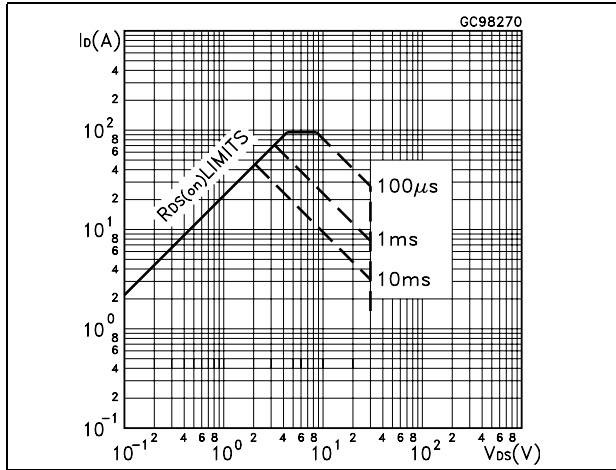
Note: For the p-channel Power MOSFET actual polarity of voltages and current has to be reversed

**STD30PF03LT4 - STD30PF03L-1**

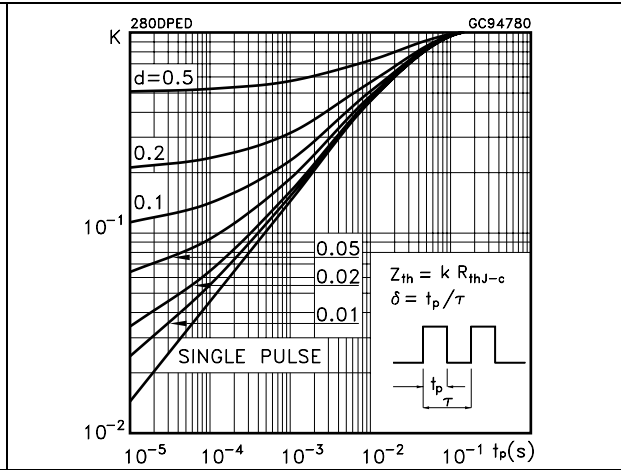
**Electrical characteristics**

**2.1 Electrical characteristics (curves)**

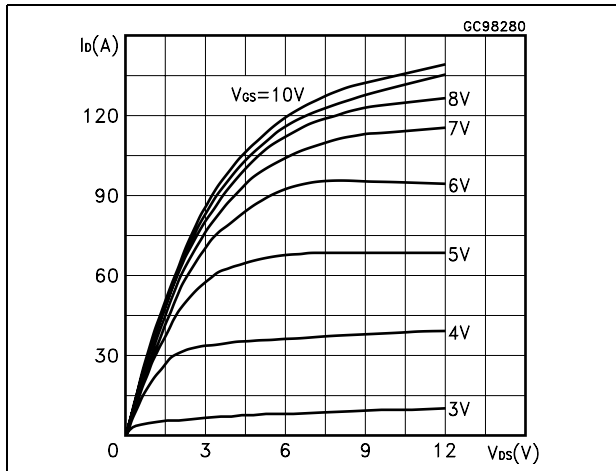
**Figure 2. Safe operating area**



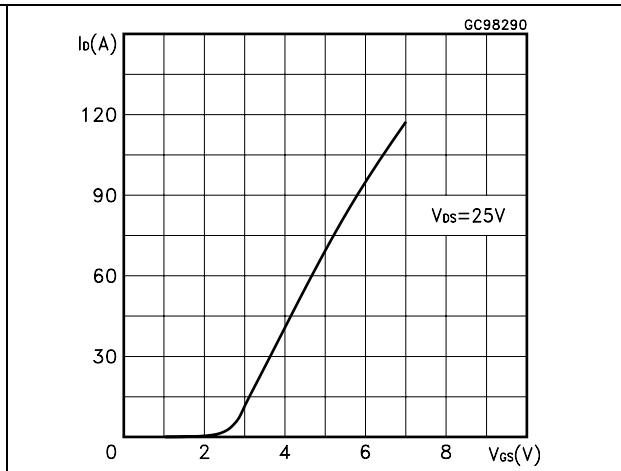
**Figure 3. Thermal impedance**



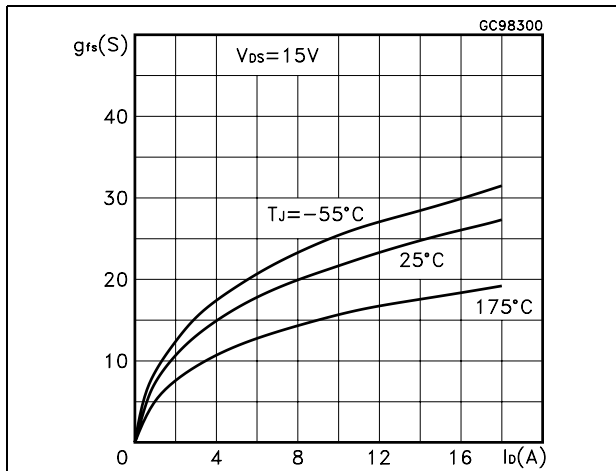
**Figure 4. Output characteristics**



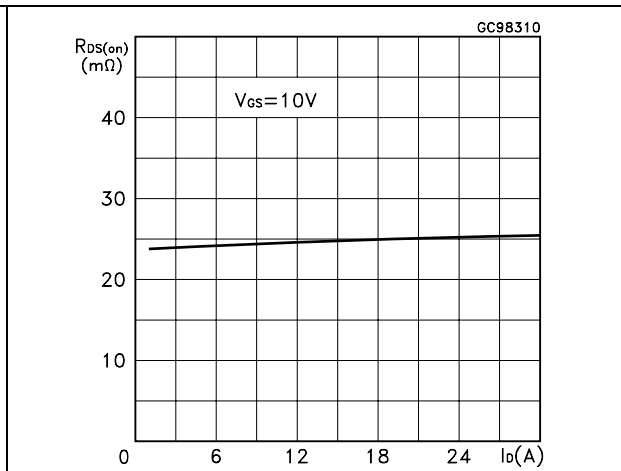
**Figure 5. Transfer characteristics**



**Figure 6. Transconductance**



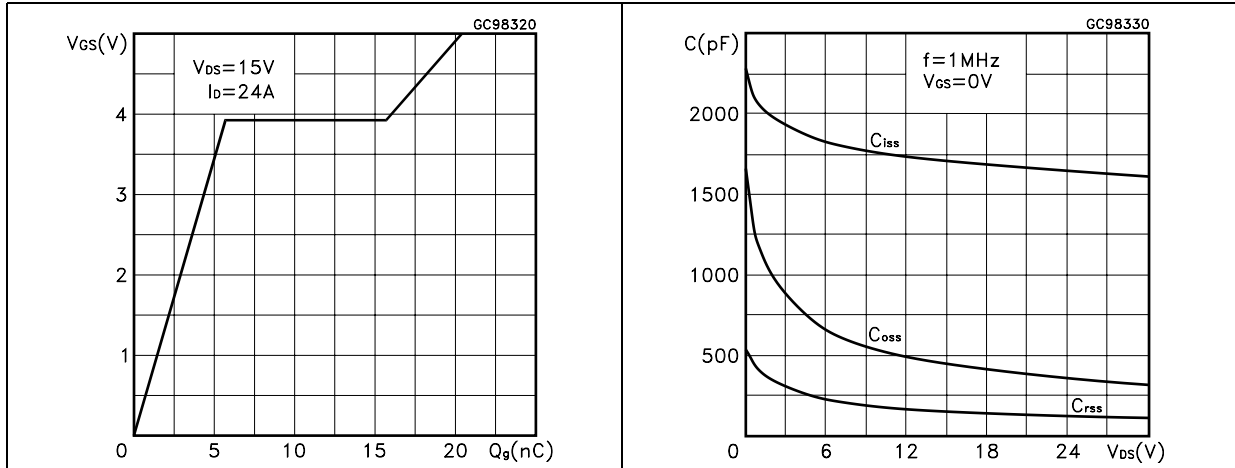
**Figure 7. Static drain-source on resistance**



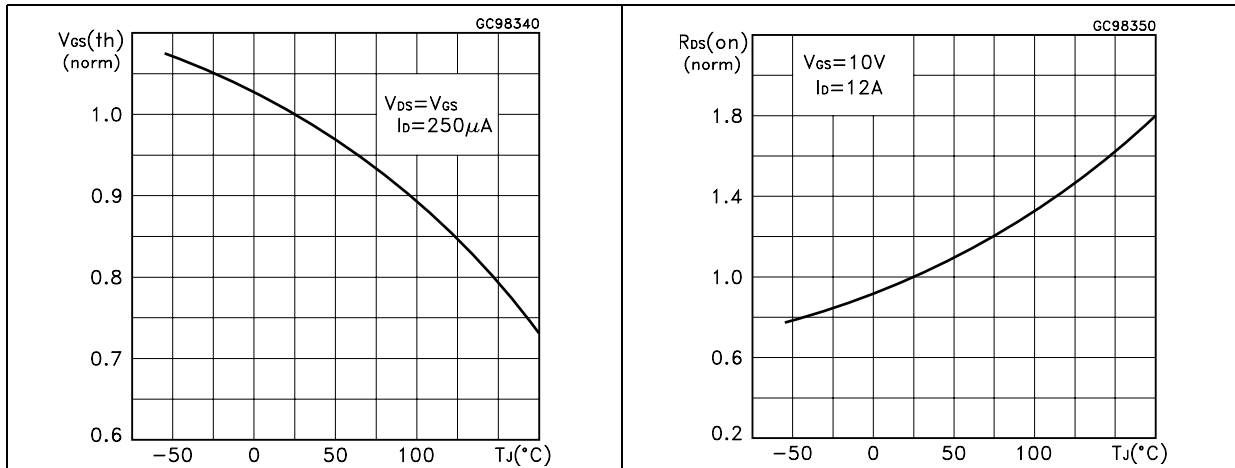
**Electrical characteristics**

**STD30PF03LT4 - STD30PF03L-1**

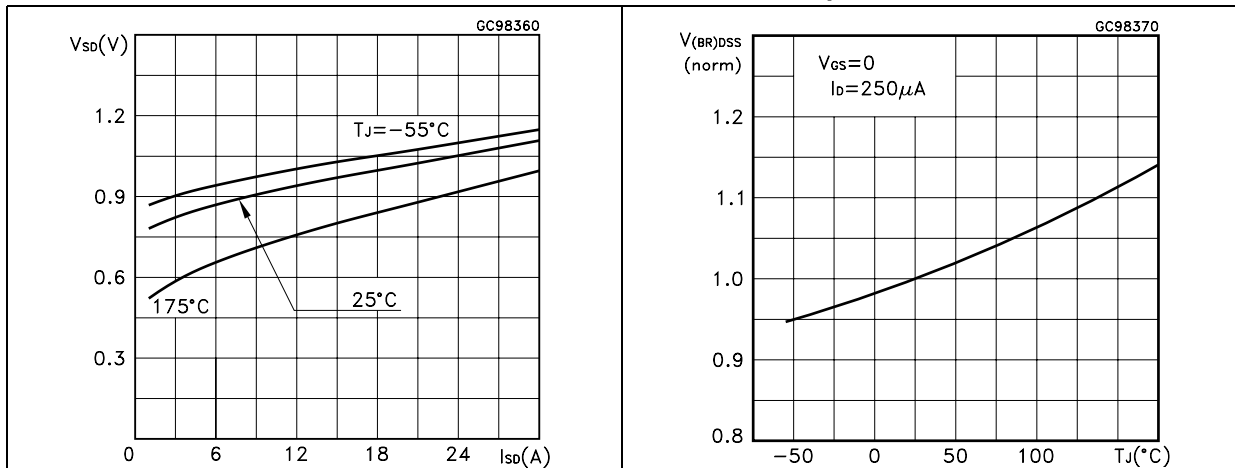
**Figure 8. Gate charge vs gate-source voltage** **Figure 9. Capacitance variations**



**Figure 10. Normalized gate threshold voltage vs temperature** **Figure 11. Normalized on resistance vs temperature**

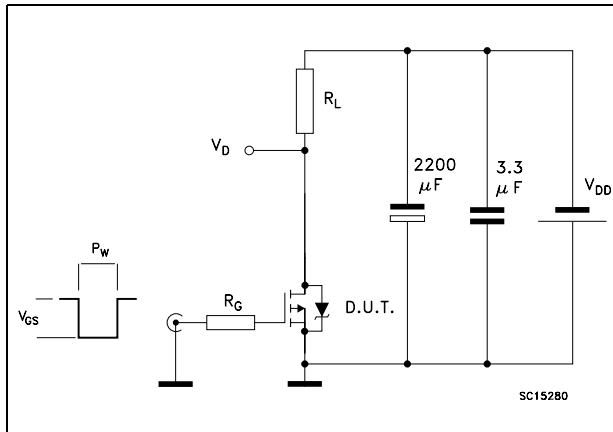


**Figure 12. Source-drain diode forward characteristics** **Figure 13. Normalized breakdown voltage vs temperature**

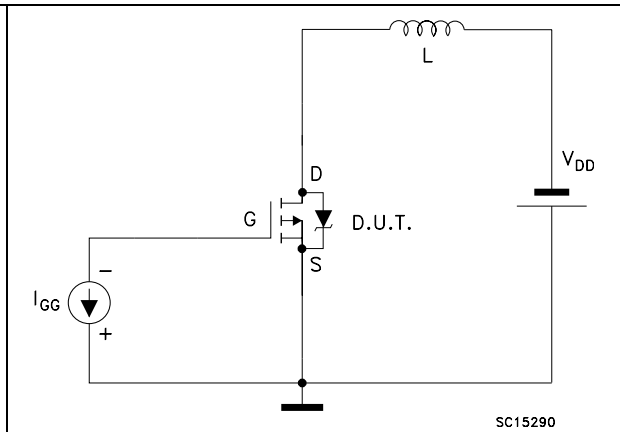


### 3 Test circuit

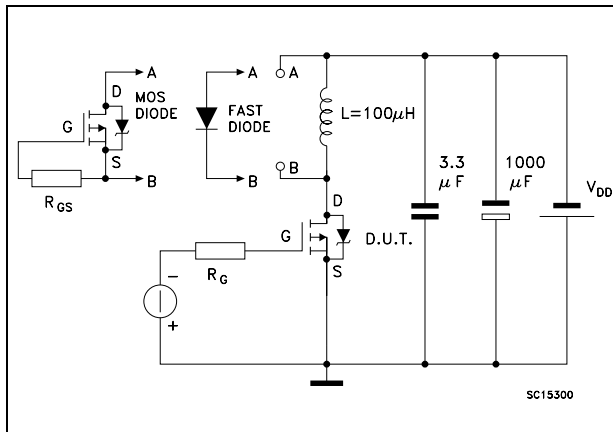
**Figure 14. Switching times test circuit for resistive load**



**Figure 15. Gate charge test circuit**



**Figure 16. Test circuit for diode recovery behavior**





## 4 Package mechanical data

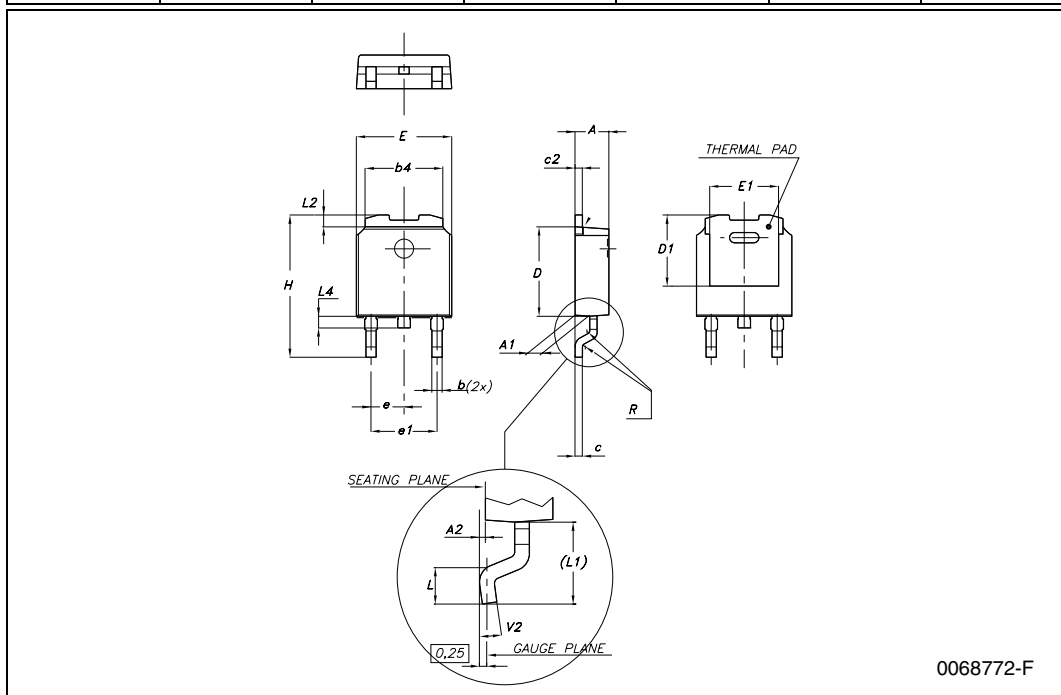
In order to meet environmental requirements, ST offers these devices in ECOPACK® packages. These packages have a Lead-free second level interconnect. The category of second level interconnect is marked on the package and on the inner box label, in compliance with JEDEC Standard JESD97. The maximum ratings related to soldering conditions are also marked on the inner box label. ECOPACK is an ST trademark. ECOPACK specifications are available at: [www.st.com](http://www.st.com)

STD30PF03LT4 - STD30PF03L-1

Package mechanical data

**DPAK MECHANICAL DATA**

DIM.	mm.			inch		
	MIN.	TYP	MAX.	MIN.	TYP.	MAX.
A	2.2		2.4	0.086		0.094
A1	0.9		1.1	0.035		0.043
A2	0.03		0.23	0.001		0.009
B	0.64		0.9	0.025		0.035
b4	5.2		5.4	0.204		0.212
C	0.45		0.6	0.017		0.023
C2	0.48		0.6	0.019		0.023
D	6		6.2	0.236		0.244
D1		5.1			0.200	
E	6.4		6.6	0.252		0.260
E1		4.7			0.185	
e		2.28			0.090	
e1	4.4		4.6	0.173		0.181
H	9.35		10.1	0.368		0.397
L	1			0.039		
(L1)		2.8			0.110	
L2		0.8			0.031	
L4	0.6		1	0.023		0.039
R		0.2			0.008	
V2	0°		8°	0°		8°



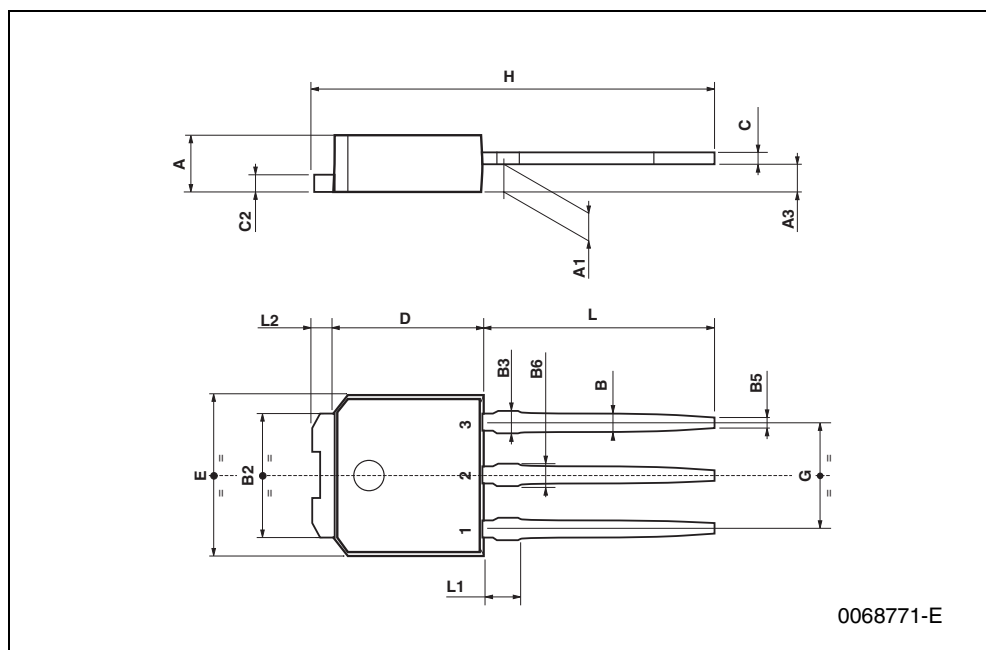
0068772-F

Package mechanical data

STD30PF03LT4 - STD30PF03L-1

TO-251 (IPAK) MECHANICAL DATA

DIM.	mm			inch		
	MIN.	TYP.	MAX.	MIN.	TYP.	MAX.
A	2.2		2.4	0.086		0.094
A1	0.9		1.1	0.035		0.043
A3	0.7		1.3	0.027		0.051
B	0.64		0.9	0.025		0.031
B2	5.2		5.4	0.204		0.212
B3			0.85			0.033
B5		0.3			0.012	
B6			0.95			0.037
C	0.45		0.6	0.017		0.023
C2	0.48		0.6	0.019		0.023
D	6		6.2	0.236		0.244
E	6.4		6.6	0.252		0.260
G	4.4		4.6	0.173		0.181
H	15.9		16.3	0.626		0.641
L	9		9.4	0.354		0.370
L1	0.8		1.2	0.031		0.047
L2		0.8	1		0.031	0.039



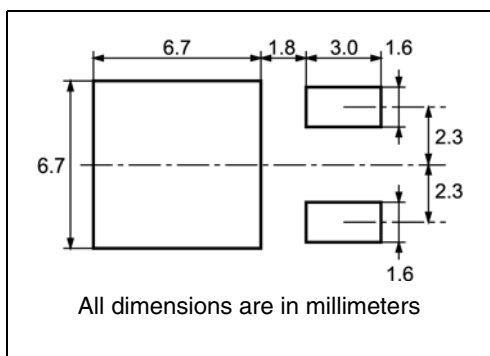
0068771-E

STD30PF03LT4 - STD30PF03L-1

Packaging mechanical data

## 5 Packaging mechanical data

### DPAK FOOTPRINT



### TAPE AND REEL SHIPMENT

40 mm min. Access hole at slot location

Full radius

Tape slot in core for tape start 2.5mm min. width

#### REEL MECHANICAL DATA

DIM.	mm		inch	
	MIN.	MAX.	MIN.	MAX.
A		330		12.992
B	1.5		0.059	
C	12.8	13.2	0.504	0.520
D	20.2		0.795	
G	16.4	18.4	0.645	0.724
N	50		1.968	
T		22.4		0.881

BASE QTY	BULK QTY
2500	2500

#### TAPE MECHANICAL DATA

DIM.	mm		inch	
	MIN.	MAX.	MIN.	MAX.
A0	6.8	7	0.267	0.275
B0	10.4	10.6	0.409	0.417
B1		12.1		0.476
D	1.5	1.6	0.059	0.063
D1	1.5		0.059	
E	1.65	1.85	0.065	0.073
F	7.4	7.6	0.291	0.299
K0	2.55	2.75	0.100	0.108
P0	3.9	4.1	0.153	0.161
P1	7.9	8.1	0.311	0.319
P2	1.9	2.1	0.075	0.082
R	40		1.574	
W	15.7	16.3	0.618	0.641

TOP COVER TAPE

User Direction of Feed

Center line of cavity

Bending radius R min.

10 pitches cumulative tolerance on tape +/- 0.2 mm

For machine ref. only including draft and radii concentric around B0

FEED DIRECTION

## 6 Revision history

Table 8. Document revision history

Date	Revision	Changes
14-Jan-2008	2	– Document reformatted – Corrected marking on <a href="#">Table 1: Device summary</a>

## STD30PF03LT4 - STD30PF03L-1

---

### Please Read Carefully:

Information in this document is provided solely in connection with ST products. STMicroelectronics NV and its subsidiaries ("ST") reserve the right to make changes, corrections, modifications or improvements, to this document, and the products and services described herein at any time, without notice.

All ST products are sold pursuant to ST's terms and conditions of sale.

Purchasers are solely responsible for the choice, selection and use of the ST products and services described herein, and ST assumes no liability whatsoever relating to the choice, selection or use of the ST products and services described herein.

No license, express or implied, by estoppel or otherwise, to any intellectual property rights is granted under this document. If any part of this document refers to any third party products or services it shall not be deemed a license grant by ST for the use of such third party products or services, or any intellectual property contained therein or considered as a warranty covering the use in any manner whatsoever of such third party products or services or any intellectual property contained therein.

**UNLESS OTHERWISE SET FORTH IN ST'S TERMS AND CONDITIONS OF SALE ST DISCLAIMS ANY EXPRESS OR IMPLIED WARRANTY WITH RESPECT TO THE USE AND/OR SALE OF ST PRODUCTS INCLUDING WITHOUT LIMITATION IMPLIED WARRANTIES OF MERCHANTABILITY, FITNESS FOR A PARTICULAR PURPOSE (AND THEIR EQUIVALENTS UNDER THE LAWS OF ANY JURISDICTION), OR INFRINGEMENT OF ANY PATENT, COPYRIGHT OR OTHER INTELLECTUAL PROPERTY RIGHT.**

**UNLESS EXPRESSLY APPROVED IN WRITING BY AN AUTHORIZED ST REPRESENTATIVE, ST PRODUCTS ARE NOT RECOMMENDED, AUTHORIZED OR WARRANTED FOR USE IN MILITARY, AIR CRAFT, SPACE, LIFE SAVING, OR LIFE SUSTAINING APPLICATIONS, NOR IN PRODUCTS OR SYSTEMS WHERE FAILURE OR MALFUNCTION MAY RESULT IN PERSONAL INJURY, DEATH, OR SEVERE PROPERTY OR ENVIRONMENTAL DAMAGE. ST PRODUCTS WHICH ARE NOT SPECIFIED AS "AUTOMOTIVE GRADE" MAY ONLY BE USED IN AUTOMOTIVE APPLICATIONS AT USER'S OWN RISK.**

Resale of ST products with provisions different from the statements and/or technical features set forth in this document shall immediately void any warranty granted by ST for the ST product or service described herein and shall not create or extend in any manner whatsoever, any liability of ST.

ST and the ST logo are trademarks or registered trademarks of ST in various countries.

Information in this document supersedes and replaces all information previously supplied.

The ST logo is a registered trademark of STMicroelectronics. All other names are the property of their respective owners.

© 2008 STMicroelectronics - All rights reserved

STMicroelectronics group of companies

Australia - Belgium - Brazil - Canada - China - Czech Republic - Finland - France - Germany - Hong Kong - India - Israel - Italy - Japan - Malaysia - Malta - Morocco - Singapore - Spain - Sweden - Switzerland - United Kingdom - United States of America

[www.st.com](http://www.st.com)