

Excellent Integrated System Limited

Stocking Distributor

Click to view price, real time Inventory, Delivery & Lifecycle Information:

[STMicroelectronics](#)

[STT4PF20V](#)

For any questions, you can email us directly:

sales@integrated-circuit.com



STT4PF20V

P-CHANNEL 20V - 0.090 Ω - 3A SOT23-6L 2.7V-DRIVE STripFET™ II POWER MOSFET

TYPE	V _{DSS}	R _{DS(on)}	I _D
STT4PF20V	20 V	< 0.11 Ω (@ 4.5 V) < 0.135 Ω (@ 2.7 V)	3 A

- TYPICAL R_{DS(on)} = 0.090 Ω @ 4.5 V
- TYPICAL R_{DS(on)} = 0.100 Ω @ 2.7 V
- ULTRA LOW THRESHOLD GATE DRIVE (2.7 V)
- STANDARD OUTLINE FOR EASY AUTOMATED SURFACE MOUNT ASSEMBLY

DESCRIPTION

This Power MOSFET is the latest development of STMicroelectronics unique "Single Feature Size™" strip-based process. The resulting transistor shows extremely high packing density for low on-resistance, rugged avalanche characteristics and less critical alignment steps therefore a remarkable manufacturing reproducibility.

APPLICATIONS

- MOBILE PHONE APPLICATIONS
- DC-DC CONVERTERS
- BATTERY MANAGEMENT IN NOMADIC EQUIPMENT

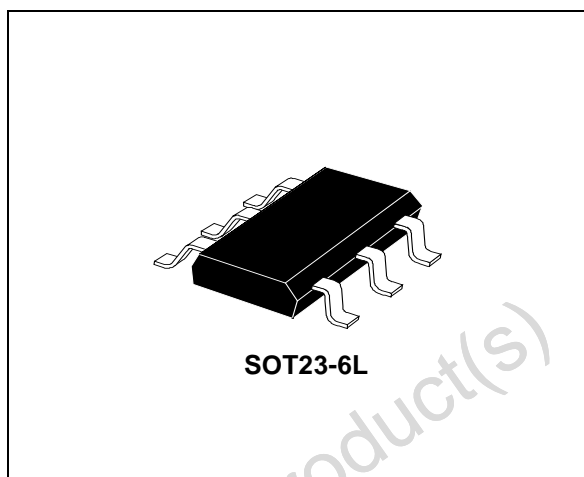

INTERNAL SCHEMATIC DIAGRAM

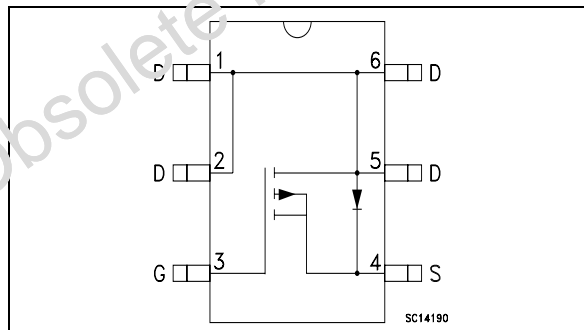

ABSOLUTE MAXIMUM RATINGS

Symbol	Parameter	Value	Unit
V _{DS}	Drain-source Voltage (V _{GS} = 0)	20	V
V _{DGR}	Drain-gate Voltage (R _{GS} = 20 kΩ)	20	V
V _{GS}	Gate- source Voltage	± 10	V
I _D	Drain Current (continuous) at T _C = 25°C	3	A
I _D	Drain Current (continuous) at T _C = 100°C	1.9	A
I _{DM} (●)	Drain Current (pulsed)	12	A
P _{tot}	Total Dissipation at T _C = 25°C	1.6	W

(●) Pulse width limited by safe operating area.

Note: For the P-CHANNEL MOSFET actual polarity of voltages and current has to be reversed

STT4PF20V

THERMAL DATA

R _{thj-amb}	(*)Thermal Resistance Junction-ambient	Max	78	°C/W
T _j	Maximum Operating Junction Temperature		150	°C
T _{stg}	storage temperature		-55 to 150	°C

(*) When Mounted on 1 inch² FR-4 board, 2 oz of Cu and t ≤ 10 sec.

ELECTRICAL CHARACTERISTICS (T_{case} = 25 °C unless otherwise specified)

OFF

Symbol	Parameter	Test Conditions	Min.	Typ.	Max.	Unit
V _{(BR)DSS}	Drain-source Breakdown Voltage	I _D = 250 μA, V _{GS} = 0	20			V
I _{DSS}	Zero Gate Voltage Drain Current (V _{GS} = 0)	V _{DS} = Max Rating V _{DS} = Max Rating T _C = 125°C			1 10	μA μA
I _{GSS}	Gate-body Leakage Current (V _{DS} = 0)	V _{GS} = ± 10V			±100	nA

ON (*)

Symbol	Parameter	Test Conditions	Min.	Typ.	Max.	Unit
V _{GS(th)}	Gate Threshold Voltage	V _{DS} = V _{GS} I _D = 250 μA	0.6			V
R _{DS(on)}	Static Drain-source On Resistance	V _{GS} = 4.5 V I _D = 1.5 A V _{GS} = 2.7 V I _D = 1.5 A		0.090 0.100	0.110 0.135	Ω Ω

DYNAMIC

Symbol	Parameter	Test Conditions	Min.	Typ.	Max.	Unit
g _{fs} (*)	Forward Transconductance	V _{DS} =15V I _D =1.5 A		6.5		S
C _{iss}	Input Capacitance	V _{DS} = 15V, f = 1 MHz, V _{GS} = 0		500		pF
C _{oss}	Output Capacitance			140		pF
C _{rss}	Reverse Transfer Capacitance			30		pF

STT4PF20V

ELECTRICAL CHARACTERISTICS (continued)

SWITCHING ON(*)

Symbol	Parameter	Test Conditions	Min.	Typ.	Max.	Unit
$t_{d(on)}$ t_r	Turn-on Delay Time Rise Time	$V_{DD} = 10\text{ V}$ $I_D = 1.5\text{ A}$ $R_G = 4.7\ \Omega$ $V_{GS} = 4.5\text{ V}$ (Resistive Load, Figure 1)		38 39		ns ns
Q_g Q_{gs} Q_{gd}	Total Gate Charge Gate-Source Charge Gate-Drain Charge	$V_{DD} = 10\text{ V}$ $I_D = 3\text{ A}$ $V_{GS} = 4.5\text{ V}$ (see test circuit, Figure 2)		5.8 1 1.4	7.8	nC nC nC

SWITCHING OFF(*)

Symbol	Parameter	Test Conditions	Min.	Typ.	Max.	Unit
$t_{d(off)}$ t_f	Turn-off Delay Time Fall Time	$V_{DD} = 10\text{ V}$ $I_D = 1.5\text{ A}$ $R_G = 4.7\ \Omega$, $V_{GS} = 4.5\text{ V}$ (Resistive Load, Figure 1)		54 12		ns ns

SOURCE DRAIN DIODE(*)

Symbol	Parameter	Test Conditions	Min.	Typ.	Max.	Unit
I_{SD} $I_{SDM}(\bullet)$	Source-drain Current Source-drain Current (pulsed)				3 12	A A
$V_{SD}(\ast)$	Forward On Voltage	$I_{SD} = 3\text{ A}$ $V_{GS} = 0$			1.2	V
t_{rr} Q_{rr} I_{RRM}	Reverse Recovery Time Reverse Recovery Charge Reverse Recovery Current	$I_{SD} = 3\text{ A}$ $di/dt = 100\text{ A}/\mu\text{s}$ $V_{DD} = 15\text{ V}$ $T_j = 150^\circ\text{C}$ (Inductive Load, Figure 3)		20 13 1.3		ns nC A

(*)Pulse width $\leq 300\ \mu\text{s}$, duty cycle 1.5 %.

(●)Pulse width limited by T_{JMAX}

Safe Operating Area

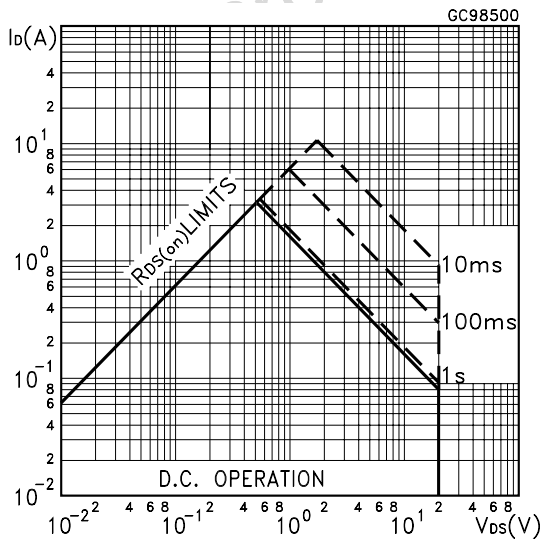

Thermal Impedance

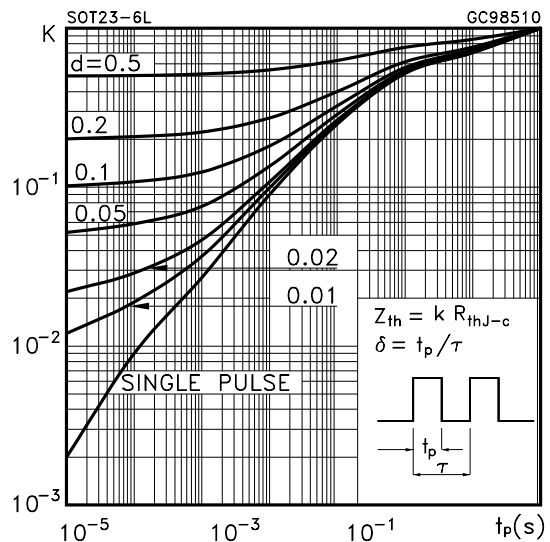

STT4PF20V

Output Characteristics

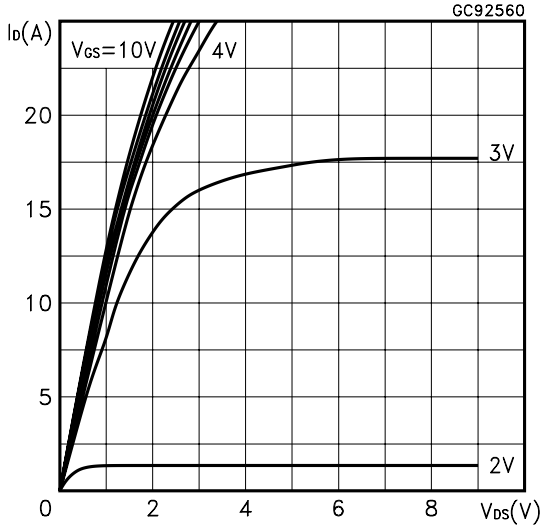

Transfer Characteristics

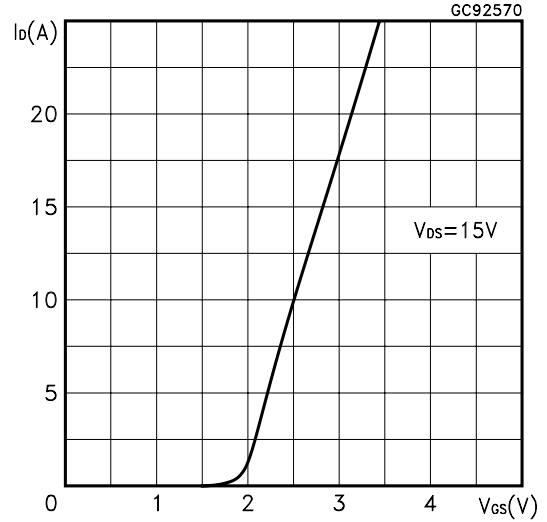

Transconductance

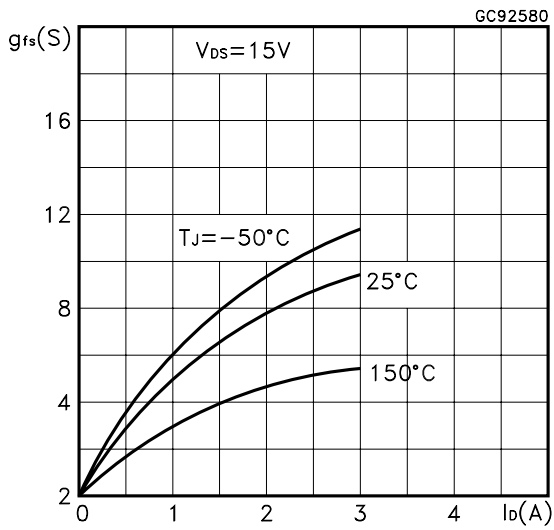

Static Drain-source On Resistance

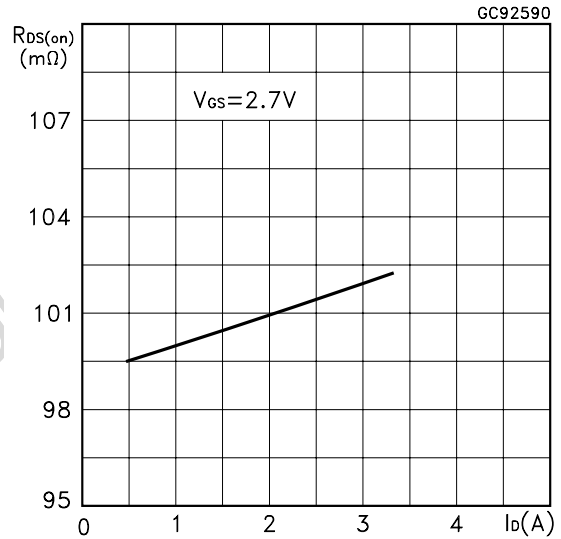

Gate Charge vs Gate-source Voltage

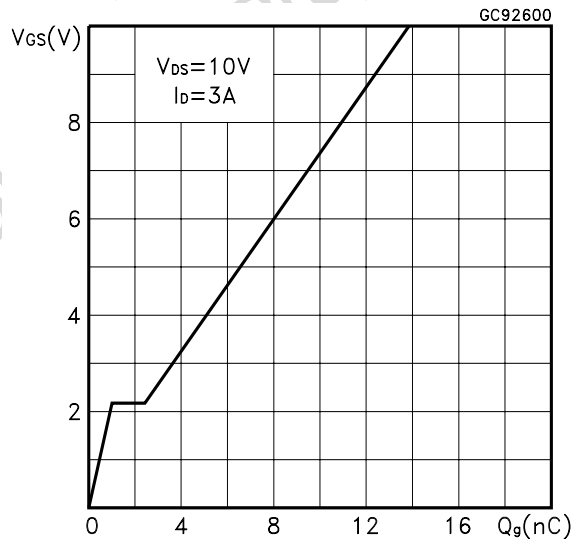

Capacitance Variations

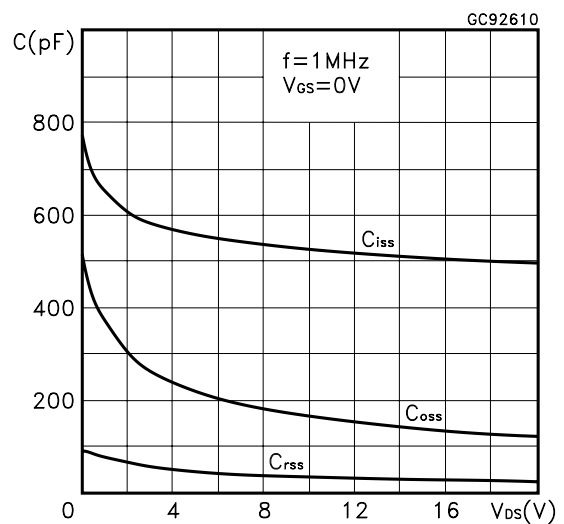

STT4PF20V

Normalized Gate Threshold Voltage vs Temperature

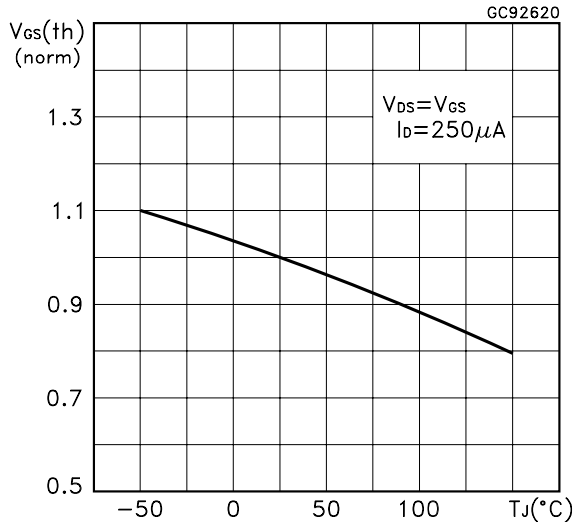

Normalized on Resistance vs Temperature

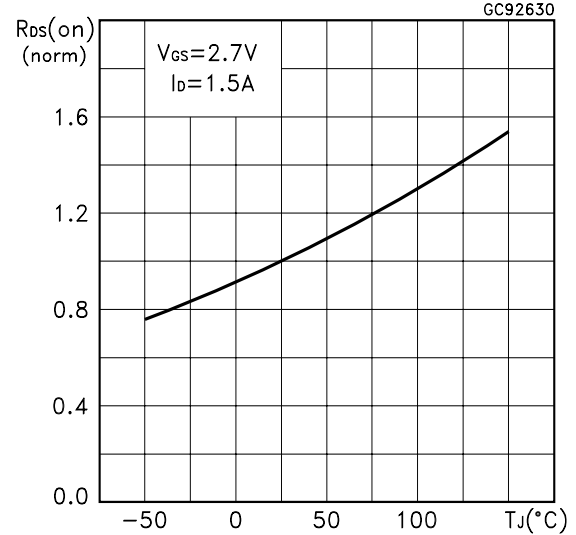

Source-drain Diode Forward Characteristics

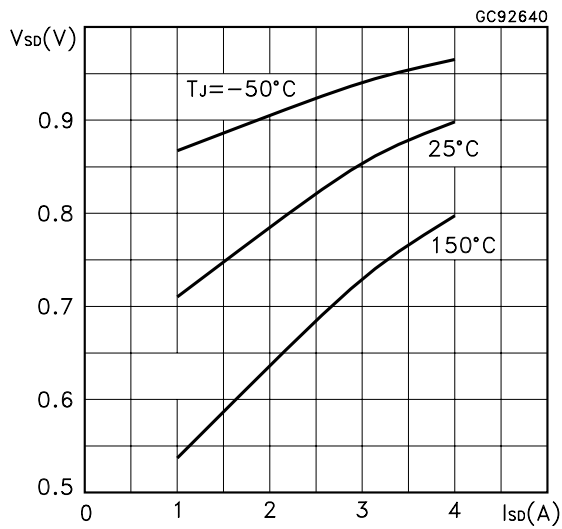

Normalized Breakdown Voltage vs Temperature

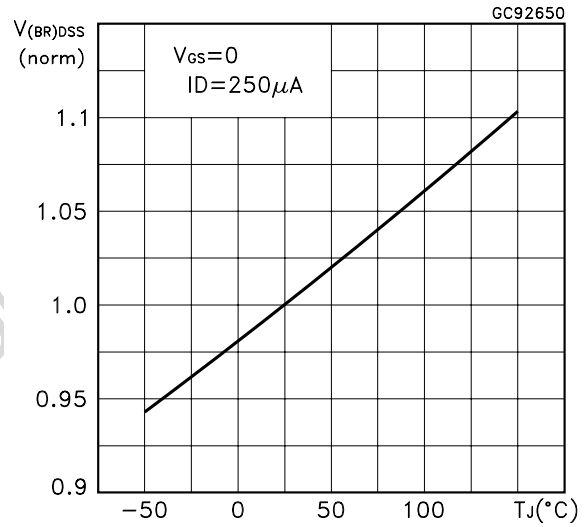

STT4PF20V

Fig. 1: Switching Times Test Circuits For Resistive Load

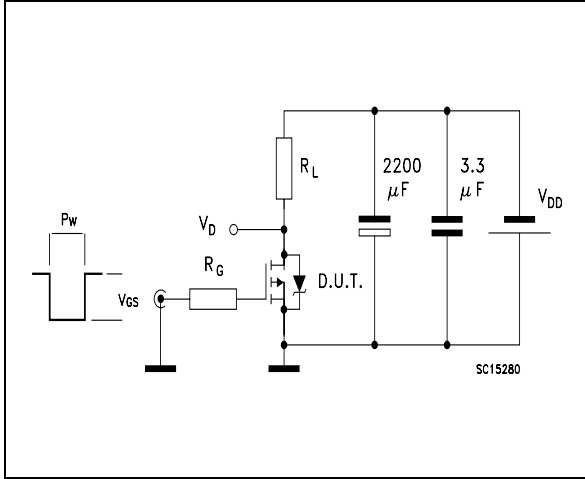

Fig. 2: Gate Charge test Circuit

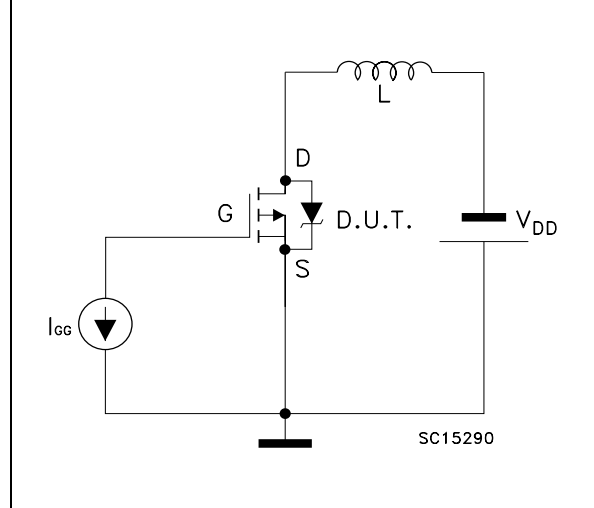
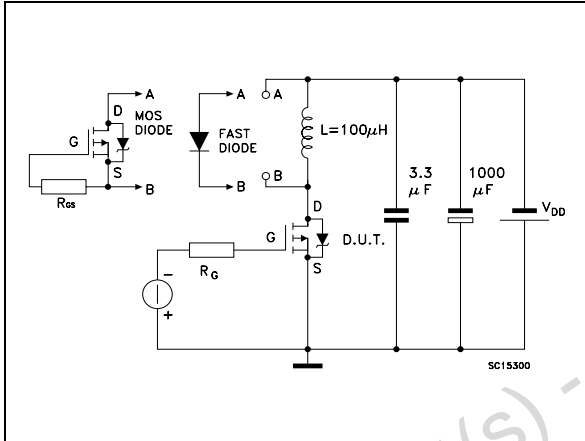

Fig. 3: Test Circuit For Diode Recovery Behaviour



Obsolete Product(s) - Obsolete Product(s)

STT4PF20V

SOT23-6L MECHANICAL DATA

DIM.	mm			mils		
	MIN.	TYP.	MAX.	MIN.	TYP.	MAX.
A	0.90		1.45	0.035		0.057
A1	0.00		0.15	0.000		0.006
A2	0.90		1.30	0.035		0.051
b	0.25		0.50	0.010		0.020
C	0.09		0.20	0.004		0.008
D	2.80		3.10	0.110		0.122
E	2.60		3.00	0.102		0.118
E1	1.50		1.75	0.059		0.069
L	0.35		0.55	0.014		0.022
e		0.95			0.037	
e1		1.90			0.075	

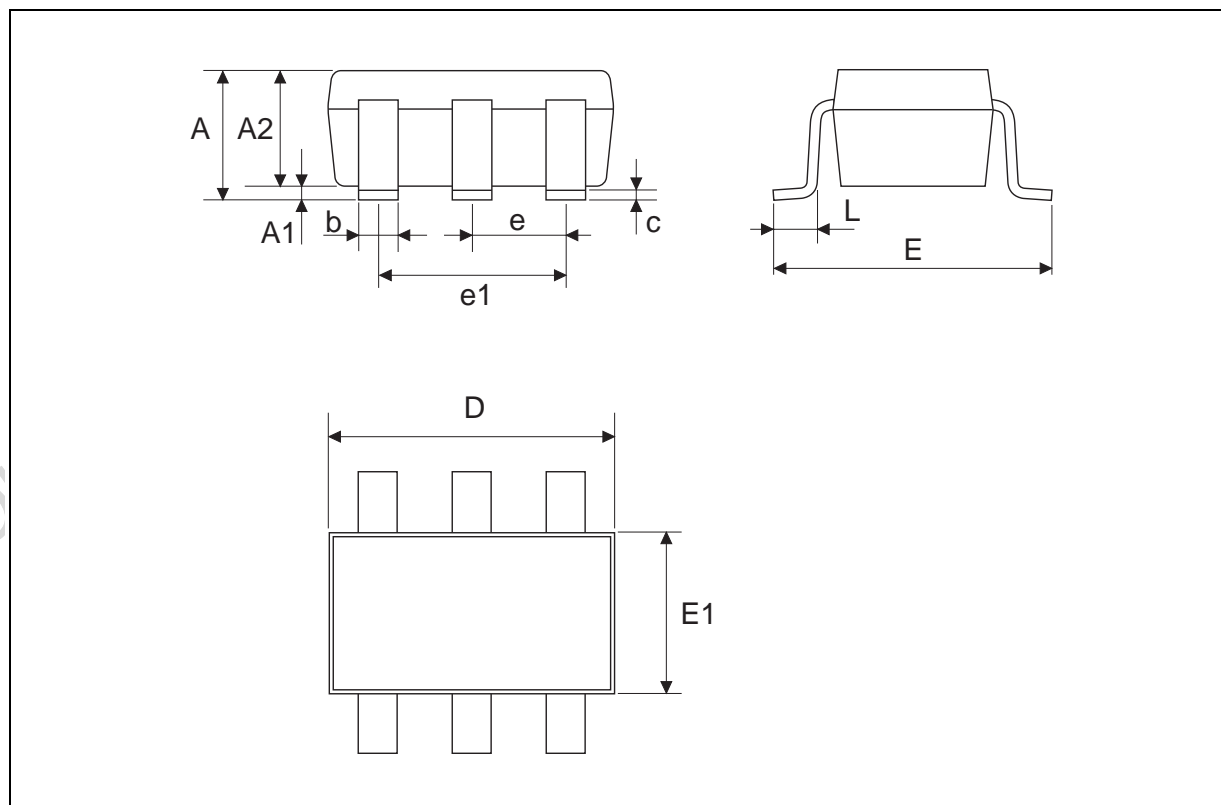

STT4PF20V

Information furnished is believed to be accurate and reliable. However, STMicroelectronics assumes no responsibility for the consequences of use of such information nor for any infringement of patents or other rights of third parties which may result from its use. No license is granted by implication or otherwise under any patent or patent rights of STMicroelectronics. Specifications mentioned in this publication are subject to change without notice. This publication supersedes and replaces all information previously supplied. STMicroelectronics products are not authorized for use as critical components in life support devices or systems without express written approval of STMicroelectronics.

The ST logo is registered trademark of STMicroelectronics
© 2003 STMicroelectronics - All Rights Reserved

All other names are the property of their respective owners.

STMicroelectronics GROUP OF COMPANIES

Australia - Brazil - Canada - China - Finland - France - Germany - Hong Kong - India - Israel - Italy - Japan - Malaysia - Malta - Morocco - Singapore - Spain - Sweden - Switzerland - United Kingdom - United States.

<http://www.st.com>