

Excellent Integrated System Limited

Stocking Distributor

Click to view price, real time Inventory, Delivery & Lifecycle Information:

[Intersil](#)
[DG444DY](#)

For any questions, you can email us directly:
sales@integrated-circuit.com

Monolithic, Quad SPST, CMOS Analog Switches

The DG444 and DG445 monolithic CMOS analog switches are drop-in replacements for the popular DG211 and DG212 series devices. They include four independent single pole single throw (SPST) analog switches and TTL and CMOS compatible digital inputs.

These switches feature lower analog ON resistance (<85Ω) and faster switch time (t_{ON} <250ns) compared to the DG211 and DG212. Charge injection has been reduced, simplifying sample and hold applications.

The improvements in the DG444 series are made possible by using a high voltage silicon-gate process. An epitaxial layer prevents the latch-up associated with older CMOS technologies. The 44V maximum voltage range permits controlling ±20V signals when operating with ±20V power supplies.

The four switches are bilateral, equally matched for AC or bidirectional signals. The ON resistance variation with analog signals is quite low over a ±5V analog input range. The switches in the DG444 and DG445 are identical, differing only in the polarity of the selection logic.

Pinout

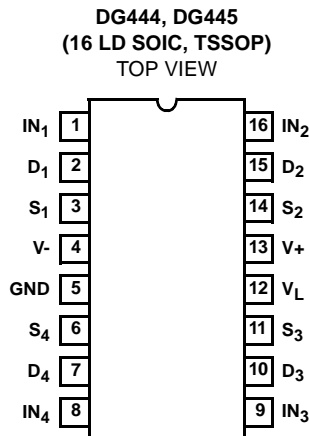

Features

- ON Resistance (Max) 85Ω
- Low Power Consumption (P_D) <35μW
- Fast Switching Action
 - t_{ON} (Max) 250ns
 - t_{OFF} (Max, DG444) 140ns
- Low Charge Injection
- Upgrade from DG211, DG212
- TTL, CMOS Compatible
- Single or Split Supply Operation
- Pb-Free Plus Anneal Available (RoHS Compliant)

Applications

- Audio Switching
- Battery Operated Systems
- Data Acquisition
- Hi-Rel Systems
- Sample and Hold Circuits
- Communication Systems
- Automatic Test Equipment

Ordering Information

| PART NUMBER | PART MARKING | TEMP. RANGE (°C) | PACKAGE | PKG. DWG. # |
|------------------|--------------|------------------|-----------------------|-------------|
| DG444DY* | DG444DY | -40 to +85 | 16 Ld SOIC | M16.15 |
| DG444DYZ* (Note) | DG444DYZ | -40 to +85 | 16 Ld SOIC (Pb-free) | M16.15 |
| DG444DVZ* (Note) | DG444DVZ | -40 to +85 | 16 Ld TSSOP (Pb-free) | M16.173 |
| DG445DY* | DG445DY | -40 to +85 | 16 Ld SOIC | M16.15 |
| DG445DYZ* (Note) | DG445DYZ | -40 to +85 | 16 Ld SOIC (Pb-free) | M16.15 |
| DG445DVZ* (Note) | DG445DVZ | -40 to +85 | 16 Ld TSSOP (Pb-free) | M16.173 |

*Add "-T" suffix for tape and reel.

NOTE: Intersil Pb-free plus anneal products employ special Pb-free material sets; molding compounds/die attach materials and 100% matte tin plate termination finish, which are RoHS compliant and compatible with both SnPb and Pb-free soldering operations. Intersil Pb-free products are MSL classified at Pb-free peak reflow temperatures that meet or exceed the Pb-free requirements of IPC/JEDEC J STD-020.

DG444, DG445

Functional Diagrams

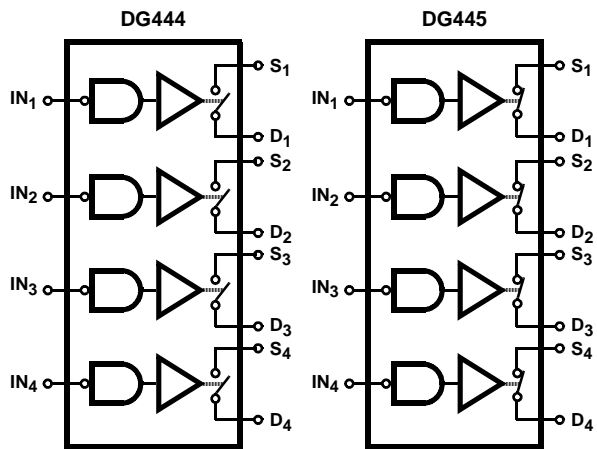

SWITCHES SHOWN FOR LOGIC "1" INPUT

TRUTH TABLE

| LOGIC | V _{IN} | DG444 | DG445 |
|-------|-----------------|-------|-------|
| 0 | ≤0.8V | ON | OFF |
| 1 | ≥2.4V | OFF | ON |

Pin Descriptions

| PIN | SYMBOL | DESCRIPTION |
|-----|-----------------|--|
| 1 | IN ₁ | Logic Control for Switch 1 |
| 2 | D ₁ | Drain (Output) Terminal for Switch 1 |
| 3 | S ₁ | Source (Input) Terminal for Switch 1 |
| 4 | V- | Negative Power Supply Terminal |
| 5 | GND | Ground Terminal (Logic Common) |
| 6 | S ₄ | Source (Input) Terminal for Switch 4 |
| 7 | D ₄ | Drain (Output) Terminal for Switch 4 |
| 8 | IN ₄ | Logic Control for Switch 4 |
| 9 | IN ₃ | Logic Control for Switch 3 |
| 10 | D ₃ | Drain (Output) Terminal for Switch 3 |
| 11 | S ₃ | Source (Input) Terminal for Switch 3 |
| 12 | V _L | Logic Reference Voltage |
| 13 | V+ | Positive Power Supply Terminal (Substrate) |
| 14 | S ₂ | Source (Input) Terminal for Switch 2 |
| 15 | D ₂ | Drain (Output) Terminal for Switch 2 |
| 16 | IN ₂ | Logic Control for Switch 2 |

Schematic Diagram (One Channel)

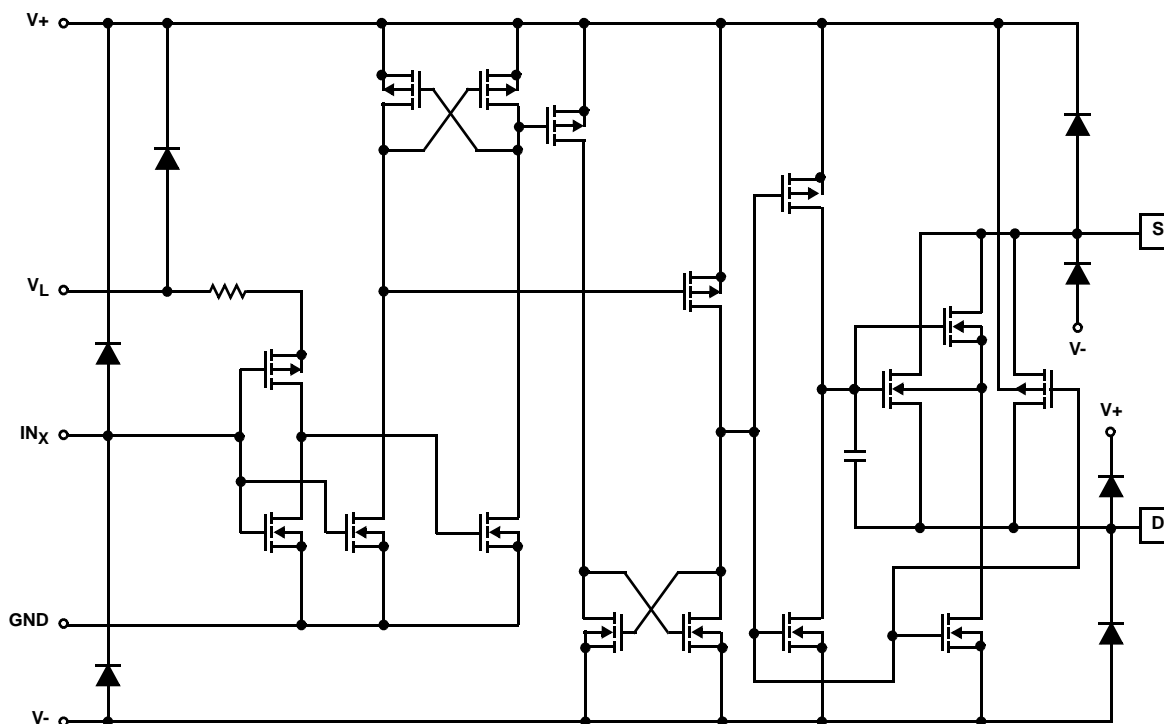

DG444, DG445

Absolute Maximum Ratings

| | |
|--|---|
| V+ to V- | 44V |
| GND to V- | 25V |
| V _L | (GND - 0.3V) to (V+) + 0.3V |
| Digital Inputs, V _S , V _D (Note 1) | (V-) -2V to (V+) + 2V or 30mA, Whichever Occurs First |
| Continuous Current (Any Terminal) | 30mA |
| Peak Current, S or D (Pulsed 1ms, 10% Duty Cycle Max) | 100mA |

Thermal Information

| | |
|---|---|
| Thermal Resistance (Typical, Note 2) | θ_{JA} (°C/W) |
| SOIC Package | 115 |
| TSSOP Package | 150 |
| Maximum Junction Temperature (Plastic Packages) | +150°C |
| Maximum Storage Temperature Range | -65°C to +150°C |
| Pb-free reflow profile | see link below |
| | http://www.intersil.com/pbfree/Pb-FreeReflow.asp |

Operating Conditions

| | |
|--------------------------|----------------|
| Temperature Range | -40°C to +85°C |
| Voltage Range | ±20V (Max) |
| Input Low Voltage | 0.8V (Max) |
| Input High Voltage | 2.4V (Min) |
| Input Rise and Fall Time | ≤20ns |

CAUTION: Stresses above those listed in "Absolute Maximum Ratings" may cause permanent damage to the device. This is a stress only rating and operation of the device at these or any other conditions above those indicated in the operational sections of this specification is not implied.

NOTES:

1. Signals on S_X, D_X, or I_{NX} exceeding V+ or V- will be clamped by internal diodes. Limit forward diode current to maximum current ratings.
2. θ_{JA} is measured with the component mounted on a high effective thermal conductivity test board in free air. See Tech Brief TB379 for details.

Electrical Specifications

Test Conditions: V+ = +15V, V- = -15V, V_L = 5V, V_{IN} = 2.4V, 0.8V (Note 3), Unless Otherwise Specified

| PARAMETER | TEST CONDITIONS | TEMP (°C) | (NOTE 4) MIN | (NOTE 5) TYP | (NOTE 4) MAX | UNITS |
|---|--|-----------|--------------|--------------|--------------|----------|
| DYNAMIC CHARACTERISTICS | | | | | | |
| Turn-ON Time, t _{ON} | R _L = 1k Ω , C _L = 35pF, V _S = ±10V (Figure 1) | +25 | - | 120 | 250 | ns |
| Turn-OFF Time, t _{OFF} | | +25 | - | 110 | 140 | ns |
| DG444 | | +25 | - | 160 | 210 | ns |
| Charge Injection, Q (Figure 2) | C _L = 1nF, V _G = 0V, R _G = 0 Ω | +25 | - | -1 | - | pC |
| OFF Isolation (Figure 4) | R _L = 50 Ω , C _L = 5pF, f = 1MHz | +25 | - | 60 | - | dB |
| Crosstalk (Channel-to-Channel) (Figure 3) | | +25 | - | -100 | - | dB |
| Source OFF Capacitance, C _{S(OFF)} | f = 1MHz, V _{ANALOG} = 0 (Figure 5) | +25 | - | 4 | - | pF |
| Drain OFF Capacitance, C _{D(OFF)} | | +25 | - | 4 | - | pF |
| Channel ON Capacitance, C _{D(ON)} + C _{S(ON)} | | +25 | - | 16 | - | pF |
| DIGITAL INPUT CHARACTERISTICS | | | | | | |
| Input Current V _{IN} Low, I _{IL} | V _{IN} Under Test = 0.8V, All Others = 2.4V | Full | -0.5 | -0.00001 | 0.5 | μ A |
| Input Current V _{IN} High, I _{IH} | V _{IN} Under Test = 2.4V, All Others = 0.8V | Full | -0.5 | 0.00001 | 0.5 | μ A |
| ANALOG SWITCH CHARACTERISTICS | | | | | | |
| Analog Signal Range, V _{ANALOG} | | Full | -15 | - | 15 | V |
| Drain-Source ON Resistance, r _{DS(ON)} | I _S = \mp 10mA, V _D = ±8.5V, V+ = 13.5V, V- = -13.5V | +25 | - | 50 | 85 | Ω |
| | | Full | - | - | 100 | Ω |
| Source OFF Leakage Current, I _{S(OFF)} | V+ = 16.5V, V- = -16.5V, V _D = ±15.5V, V _S = \mp 15.5V | +25 | -0.5 | 0.01 | 0.5 | nA |
| | | +85 | -5 | - | 5 | nA |

DG444, DG445

Electrical Specifications Test Conditions: $V_+ = +15V$, $V_- = -15V$, $V_L = 5V$, $V_{IN} = 2.4V, 0.8V$ (Note 3),
 Unless Otherwise Specified **(Continued)**

| PARAMETER | TEST CONDITIONS | TEMP (°C) | (NOTE 4) MIN | (NOTE 5) TYP | (NOTE 4) MAX | UNITS |
|---|---|-----------|--------------|--------------|--------------|---------|
| Drain OFF Leakage Current, $I_{D(OFF)}$ | $V_+ = 16.5V$, $V_- = -16.5V$, $V_D = \pm 15.5V$, $V_S = \mp 15.5V$ | +25 | -0.5 | 0.01 | 0.5 | nA |
| | | +85 | -5 | - | 5 | nA |
| Channel ON Leakage Current, $I_{D(ON)} + I_{S(ON)}$ | $V_+ = 16.5V$, $V_- = -16.5V$, $V_S = V_D, = \pm 15.5V$ | +25 | -0.5 | 0.08 | 0.5 | nA |
| | | +85 | -10 | - | 10 | nA |
| POWER SUPPLY CHARACTERISTICS | | | | | | |
| Positive Supply Current, I_+ | $V_+ = 16.5V$, $V_- = -16.5V$, $V_{IN} = 0V$ or $5V$ | +25 | - | 0.001 | 1 | μA |
| | | +85 | - | - | 5 | μA |
| Negative Supply Current, I_- | | +25 | -1 | -0.0001 | - | μA |
| | | +85 | -5 | - | - | μA |
| Logic Supply Current, I_L | | +25 | - | 0.001 | 1 | μA |
| | | +85 | - | - | 5 | μA |
| Ground Current, I_{GND} | | +25 | -1 | -0.001 | - | μA |
| | | +85 | -5 | - | - | μA |

Electrical Specifications (Single Supply) Test Conditions: $V_+ = 12V$, $V_- = 0V$, $V_L = 5V$, $V_{IN} = 2.4V, 0.8V$ (Note 3),
 Unless Otherwise Specified

| PARAMETER | TEST CONDITIONS | TEMP (°C) | (NOTE 4) MIN | (NOTE 5) TYP | (NOTE 4) MAX | UNITS |
|--|---|-----------|--------------|--------------|--------------|----------|
| DYNAMIC CHARACTERISTICS | | | | | | |
| Turn-ON Time, t_{ON} | $R_L = 1k\Omega$, $C_L = 35pF$, $V_S = 8V$ (Figure 1) | +25 | - | 300 | 450 | ns |
| Turn-OFF Time, t_{OFF} | | +25 | - | 60 | 200 | ns |
| Charge Injection, Q (Figure 2) | $C_L = 1nF$, $V_G = 6V$, $R_G = 0\Omega$ | +25 | - | 2 | - | pC |
| ANALOG SWITCH CHARACTERISTICS | | | | | | |
| Analog Signal Range, V_{ANALOG} | | Full | 0 | - | 12 | V |
| Drain-Source ON Resistance, $r_{DS(ON)}$ | $I_S = -10mA$, $V_D = 3V, 8V$ $V_+ = 10.8V$, $V_L = 5.25V$ | +25 | - | 100 | 160 | Ω |
| | | Full | - | - | 200 | Ω |
| POWER SUPPLY CHARACTERISTICS | | | | | | |
| Positive Supply Current, I_+ | $V_+ = 13.2V$, $V_{IN} = 0V$ or $5V$, $V_L = 5.25V$ | +25 | - | 0.001 | 1 | μA |
| | | Full | - | - | 5 | μA |
| Negative Supply Current, I_- | | +25 | -1 | -0.0001 | - | μA |
| | | Full | -5 | - | - | μA |
| Logic Supply Current, I_L | | +25 | - | 0.001 | 1 | μA |
| | | Full | - | - | 5 | μA |
| Ground Current, I_{GND} | | +25 | -1 | -0.001 | - | μA |
| | | Full | -5 | - | - | μA |

NOTES:

- V_{IN} = input voltage to perform proper function.
- The algebraic convention whereby the most negative value is a minimum and the most positive a maximum, is used in this data sheet.
- Typical values are for DESIGN AID ONLY, not guaranteed nor subject to production testing.

DG444, DG445

Test Circuits and Waveforms

V_O is the steady state output with the switch on. Feedthrough via switch capacitance may result in spikes at the leading and trailing edge of the output waveform.

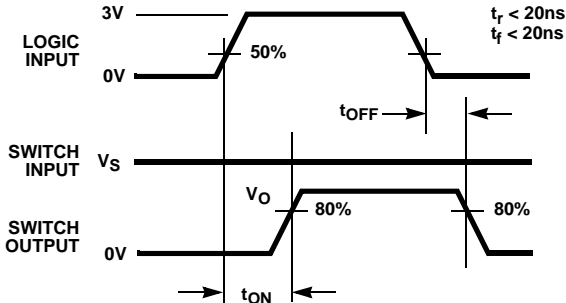
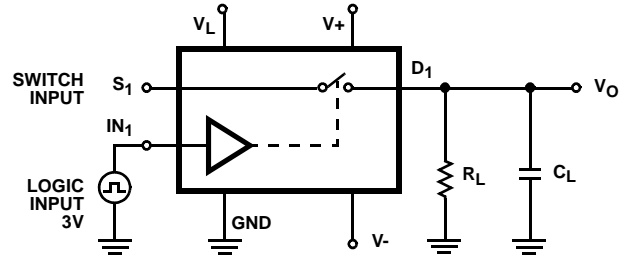

FIGURE 1A. MEASUREMENT POINTS



Repeat test for Channels 2, 3 and 4.
 For load conditions, see Specifications. C_L includes fixture and stray capacitance.

$$V_O = V_S \frac{R_L}{R_L + r_{DS(ON)}}$$

FIGURE 1B. TEST CIRCUIT

FIGURE 1. SWITCHING TIMES

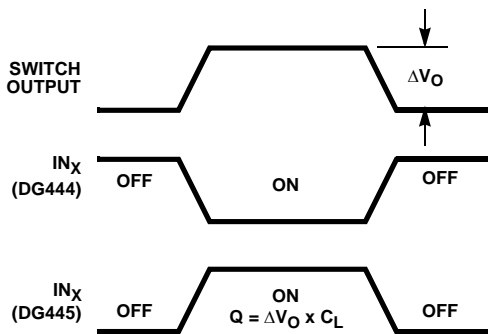

FIGURE 2A. MEASUREMENT POINTS

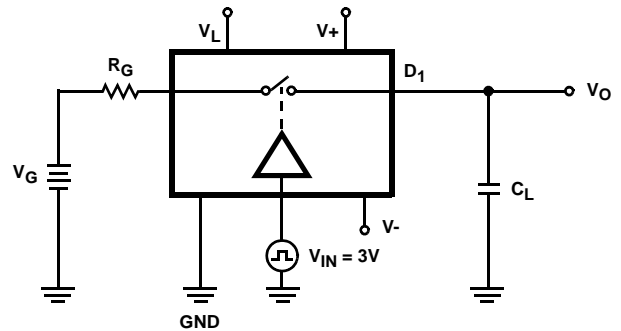

FIGURE 2B. TEST CIRCUIT

FIGURE 2. CHARGE INJECTION

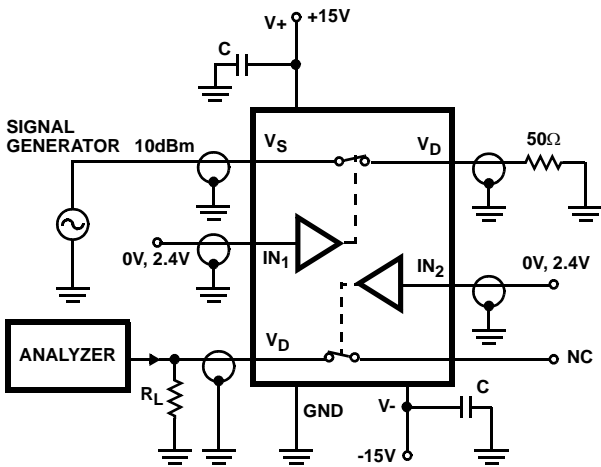

FIGURE 3. CROSSTALK TEST CIRCUIT

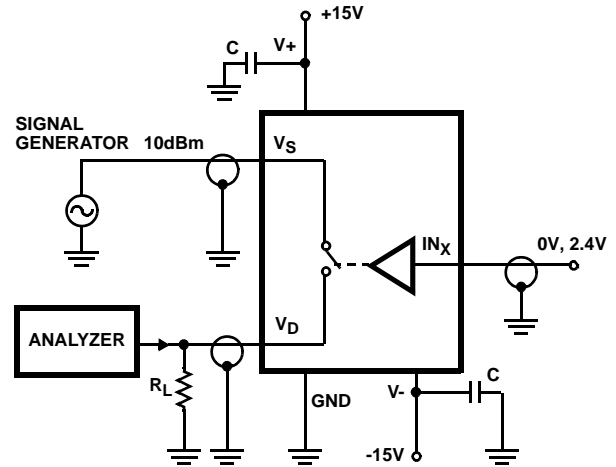

FIGURE 4. OFF ISOLATION TEST CIRCUIT

DG444, DG445

Test Circuits and Waveforms (Continued)

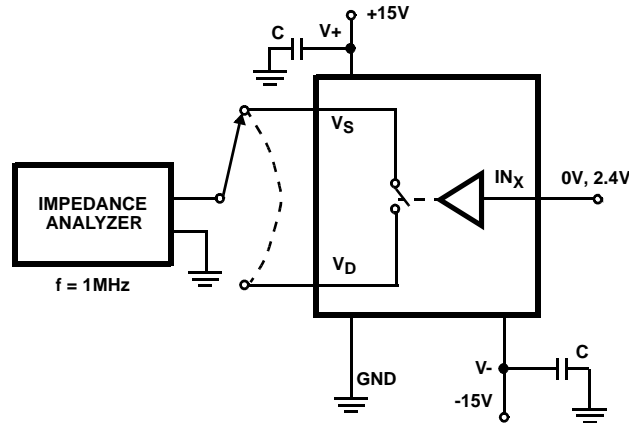
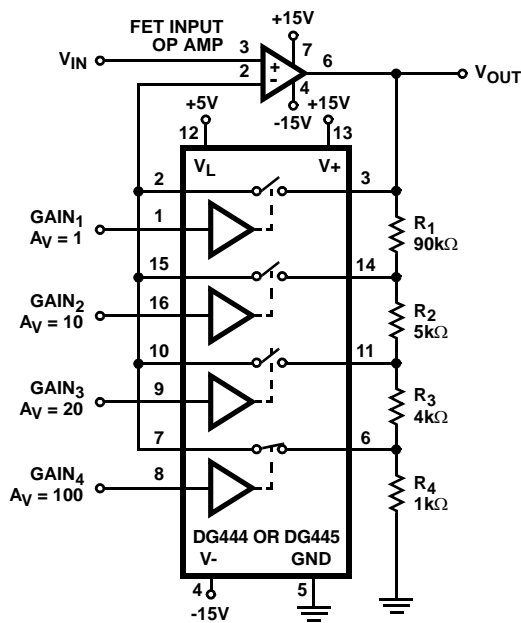

FIGURE 5. SOURCE/DRAIN CAPACITANCES TEST CIRCUIT

Application Information



GAIN ERROR IS DETERMINED ONLY BY THE RESISTOR TOLERANCE, OP AMP OFFSET AND CMRR WILL LIMIT ACCURACY OF CIRCUIT

$$\frac{V_{OUT}}{V_{IN}} = \frac{R_1 + R_2 + R_3 + R_4}{R_4} = 100$$

WITH SW₄ CLOSED

FIGURE 6. PRECISION WEIGHTED RESISTOR PROGRAMMABLE GAIN AMPLIFIER

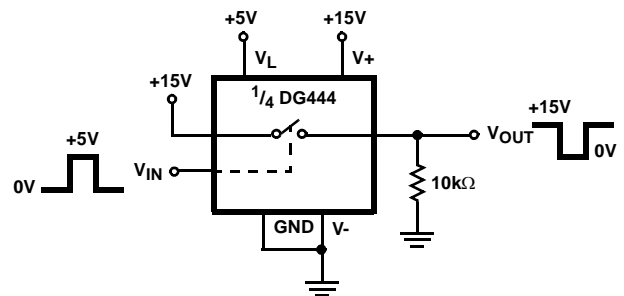

FIGURE 7. LEVEL SHIFTER

DG444, DG445

Typical Performance Curves

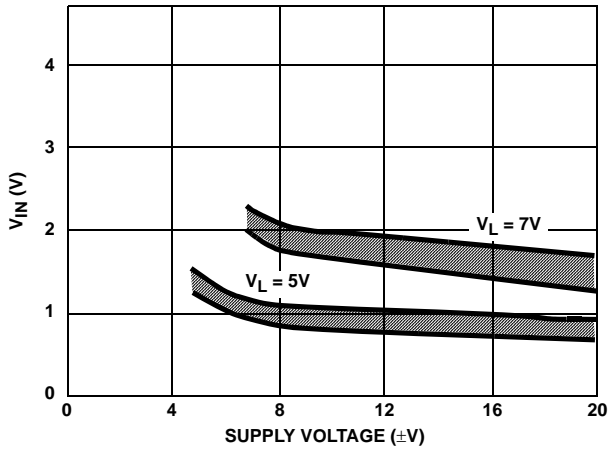

FIGURE 8. SWITCHING THRESHOLD vs SUPPLY VOLTAGE

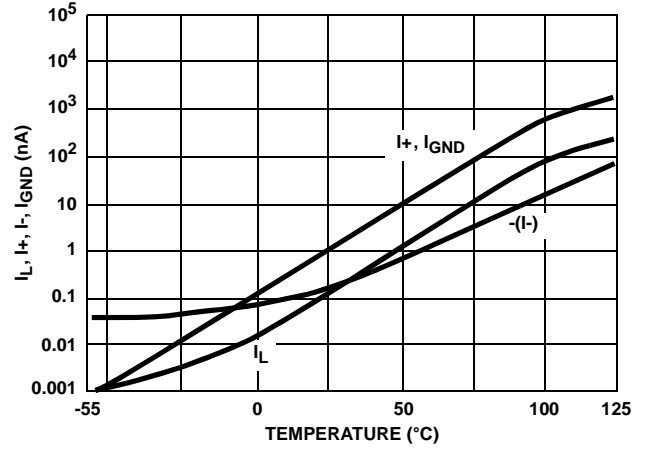

FIGURE 9. SUPPLY CURRENT vs TEMPERATURE

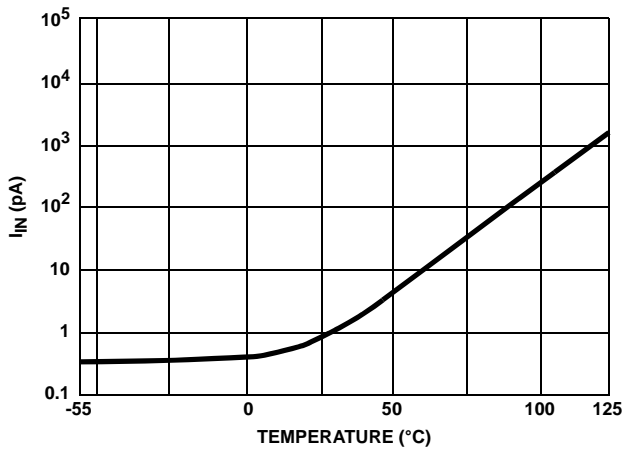

FIGURE 10. INPUT CURRENT vs TEMPERATURE

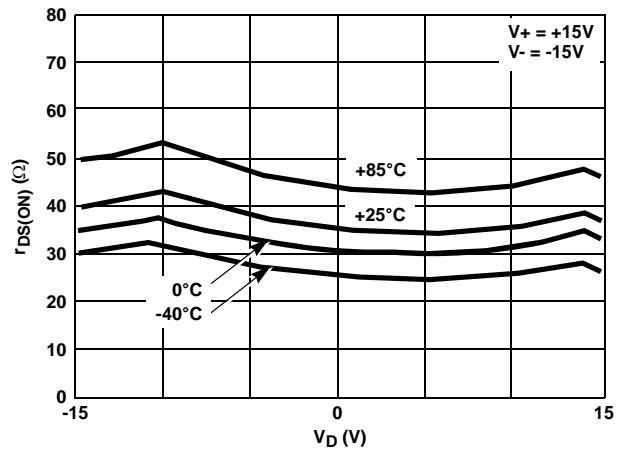

FIGURE 11. $r_{DS(ON)}$ vs V_D AND TEMPERATURE

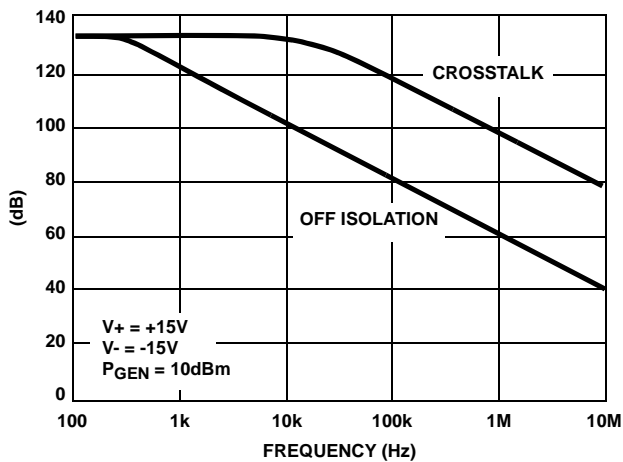

FIGURE 12. CROSSTALK REJECTION AND OFF ISOLATION vs FREQUENCY

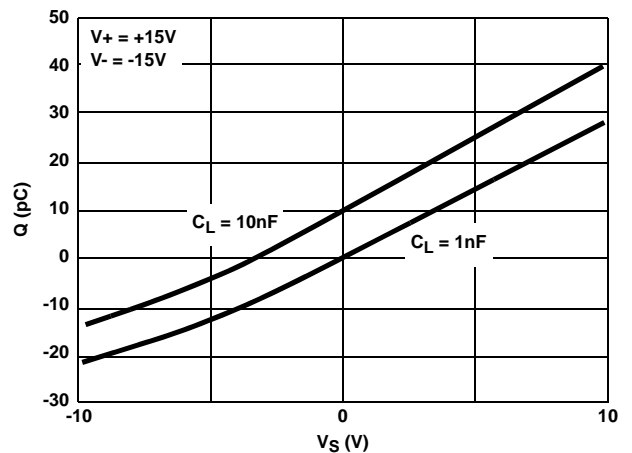

FIGURE 13. CHARGE INJECTION vs SOURCE VOLTAGE

DG444, DG445

Typical Performance Curves (Continued)

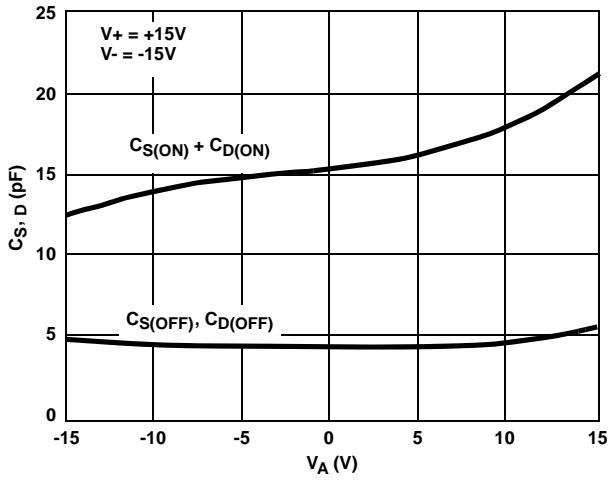

FIGURE 14. SOURCE/DRAIN CAPACITANCE vs ANALOG VOLTAGE

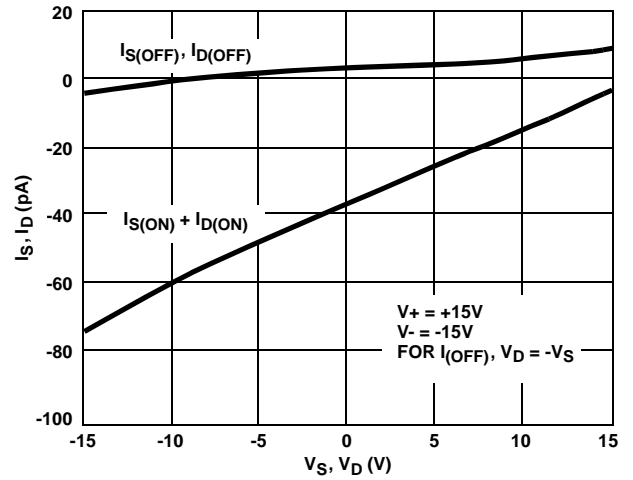

FIGURE 15. LEAKAGE CURRENTS vs ANALOG VOLTAGE

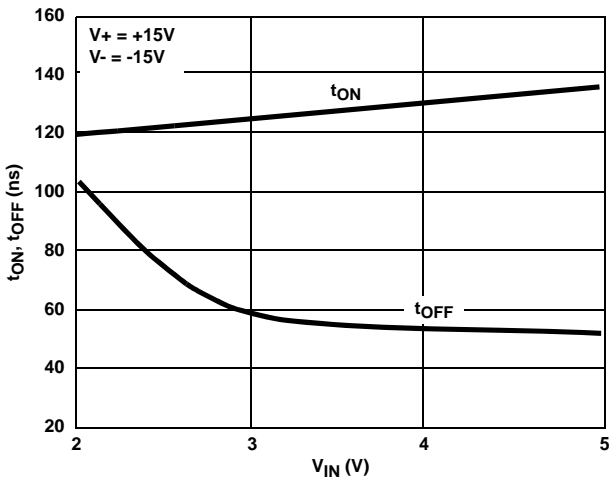

FIGURE 16. SWITCHING TIME vs INPUT VOLTAGE (DG444)

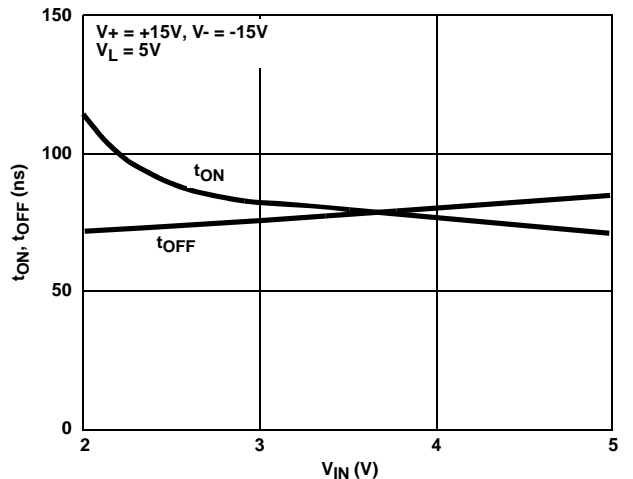

FIGURE 17. SWITCHING TIME vs INPUT VOLTAGE (DG445)

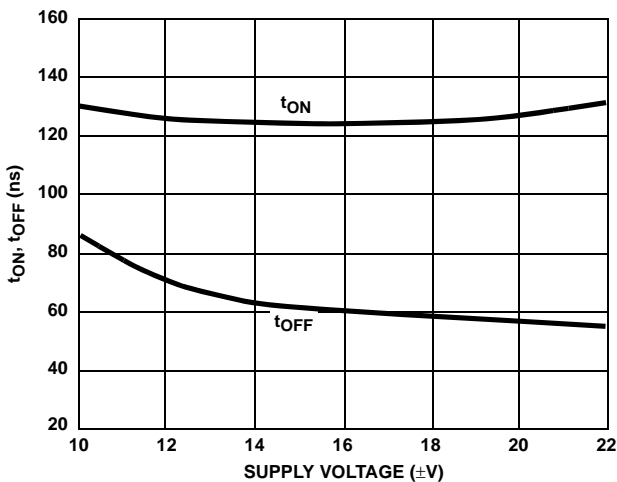

FIGURE 18. SWITCHING TIME vs POWER SUPPLY VOLTAGE (DG444)

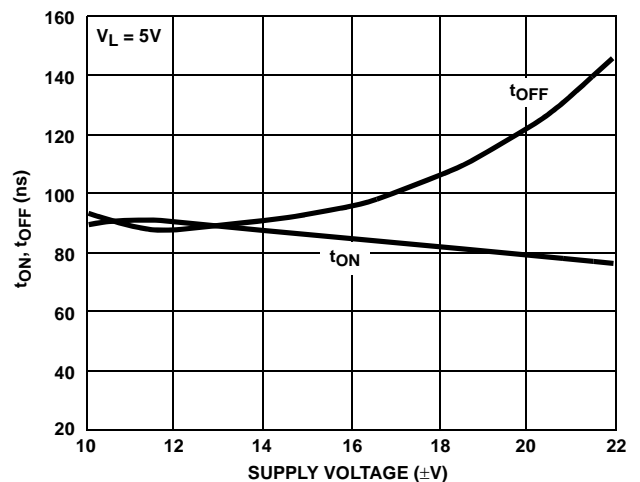

FIGURE 19. SWITCHING TIME vs POWER SUPPLY VOLTAGE (DG445)

DG444, DG445

Typical Performance Curves (Continued)

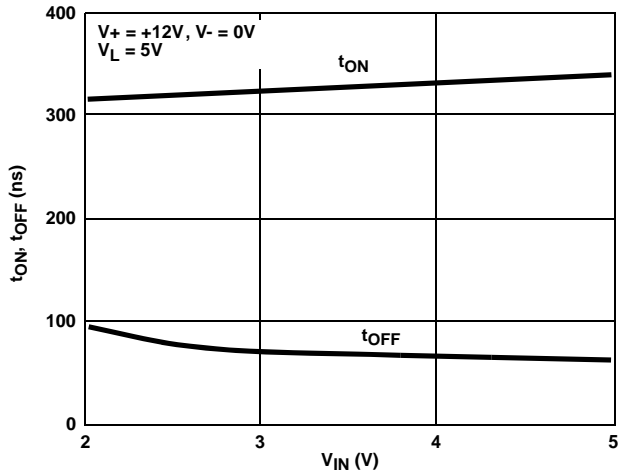

FIGURE 20. SWITCHING TIME vs INPUT VOLTAGE (DG444) (SINGLE 12V SUPPLY)

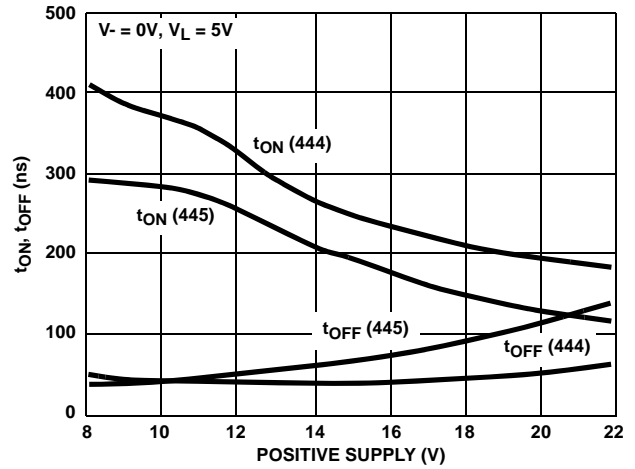

FIGURE 21. SWITCHING TIMES vs SINGLE SUPPLY VOLTAGE

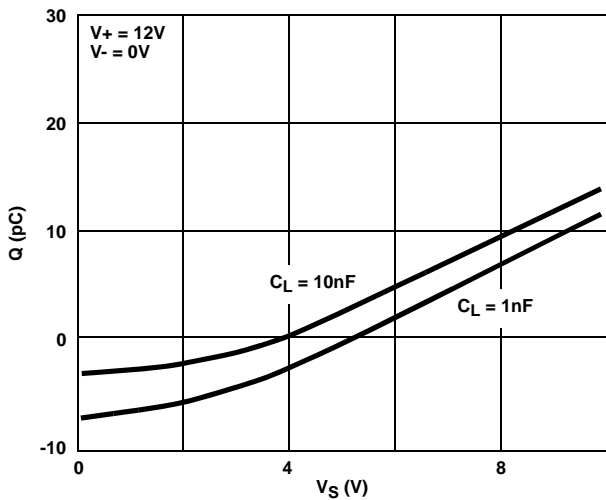

FIGURE 22. CHARGE INJECTION vs SOURCE VOLTAGE (SINGLE 12V SUPPLY)

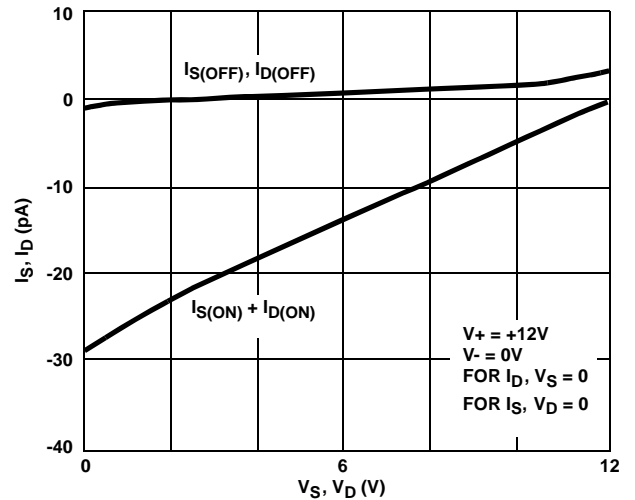

FIGURE 23. SOURCE/DRAIN LEAKAGE CURRENTS (SINGLE 12V SUPPLY)

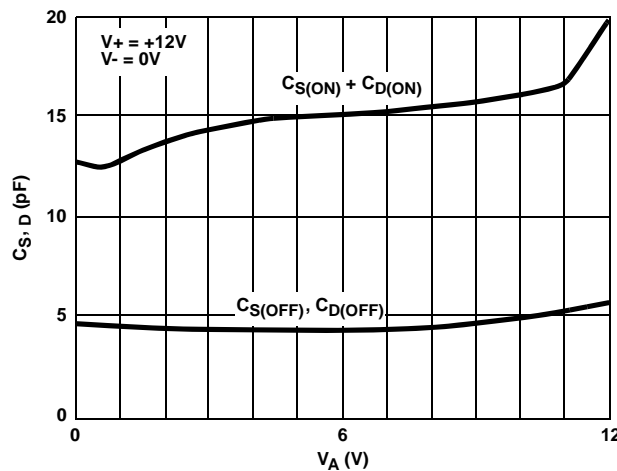

FIGURE 24. SOURCE/DRAIN CAPACITANCE vs ANALOG VOLTAGE (SINGLE 12V SUPPLY)

DG444, DG445

Die Characteristics

METALLIZATION:

Type: SiAl
 Thickness: $12\text{k}\text{\AA} \pm 1\text{k}\text{\AA}$

PASSIVATION:

Type: Nitride
 Thickness: $8\text{k}\text{\AA} \pm 1\text{k}\text{\AA}$

WORST CASE CURRENT DENSITY:

$9.1 \times 10^4 \text{ A/cm}^2$

Metallization Mask Layout

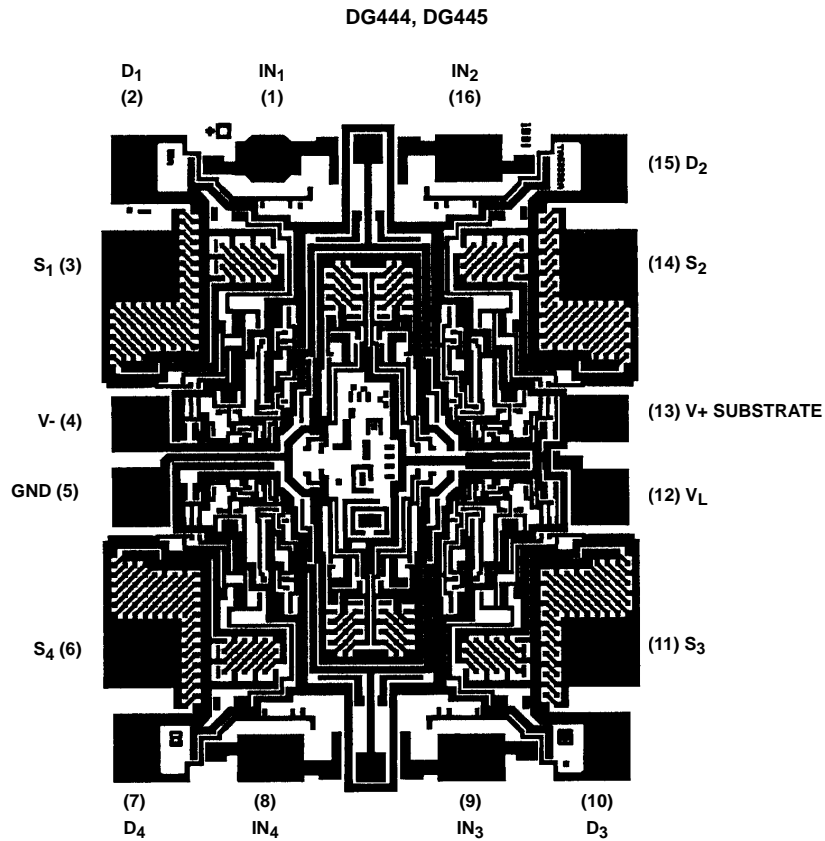

DG444, DG445

Thin Shrink Small Outline Plastic Packages (TSSOP)

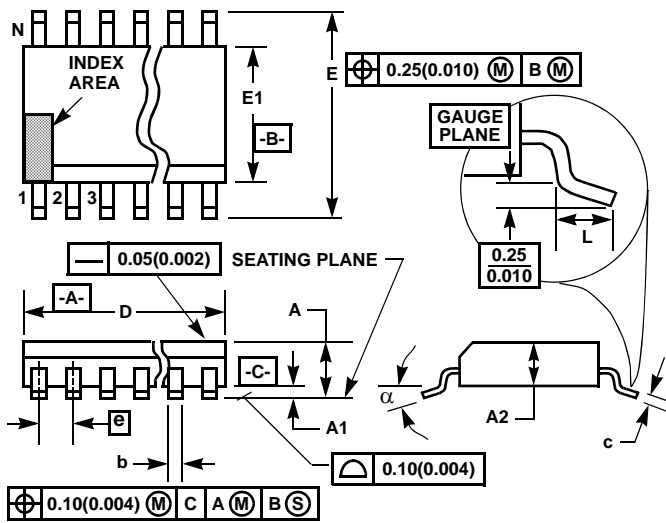

M16.173
16 LEAD THIN SHRINK SMALL OUTLINE PLASTIC PACKAGE

| SYMBOL | INCHES | | MILLIMETERS | | NOTES |
|----------|-----------|-------|-------------|------|-------|
| | MIN | MAX | MIN | MAX | |
| A | - | 0.043 | - | 1.10 | - |
| A1 | 0.002 | 0.006 | 0.05 | 0.15 | - |
| A2 | 0.033 | 0.037 | 0.85 | 0.95 | - |
| b | 0.0075 | 0.012 | 0.19 | 0.30 | 9 |
| c | 0.0035 | 0.008 | 0.09 | 0.20 | - |
| D | 0.193 | 0.201 | 4.90 | 5.10 | 3 |
| E1 | 0.169 | 0.177 | 4.30 | 4.50 | 4 |
| e | 0.026 BSC | | 0.65 BSC | | - |
| E | 0.246 | 0.256 | 6.25 | 6.50 | - |
| L | 0.020 | 0.028 | 0.50 | 0.70 | 6 |
| N | 16 | | 16 | | 7 |
| α | 0° | 8° | 0° | 8° | - |

NOTES:

1. These package dimensions are within allowable dimensions of JEDEC MO-153-AB, Issue E.
2. Dimensioning and tolerancing per ANSI Y14.5M-1982.
3. Dimension "D" does not include mold flash, protrusions or gate burrs. Mold flash, protrusion and gate burrs shall not exceed 0.15mm (0.006 inch) per side.
4. Dimension "E1" does not include interlead flash or protrusions. Interlead flash and protrusions shall not exceed 0.15mm (0.006 inch) per side.
5. The chamfer on the body is optional. If it is not present, a visual index feature must be located within the crosshatched area.
6. "L" is the length of terminal for soldering to a substrate.
7. "N" is the number of terminal positions.
8. Terminal numbers are shown for reference only.
9. Dimension "b" does not include dambar protrusion. Allowable dambar protrusion shall be 0.08mm (0.003 inch) total in excess of "b" dimension at maximum material condition. Minimum space between protrusion and adjacent lead is 0.07mm (0.0027 inch).
10. Controlling dimension: MILLIMETER. Converted inch dimensions are not necessarily exact. (Angles in degrees)

Rev. 1 2/02

DG444, DG445

Small Outline Plastic Packages (SOIC)

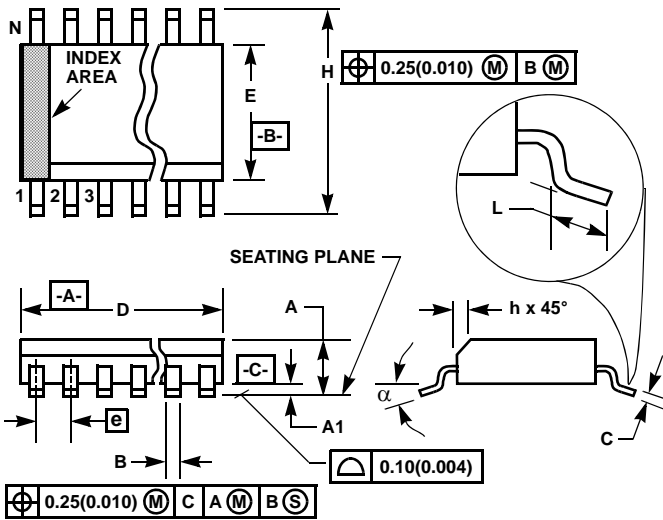

M16.15 (JEDEC MS-012-AC ISSUE C)
16 LEAD NARROW BODY SMALL OUTLINE PLASTIC PACKAGE

| SYMBOL | INCHES | | MILLIMETERS | | NOTES |
|----------|-----------|--------|-------------|-------|-------|
| | MIN | MAX | MIN | MAX | |
| A | 0.0532 | 0.0688 | 1.35 | 1.75 | - |
| A1 | 0.0040 | 0.0098 | 0.10 | 0.25 | - |
| B | 0.013 | 0.020 | 0.33 | 0.51 | 9 |
| C | 0.0075 | 0.0098 | 0.19 | 0.25 | - |
| D | 0.3859 | 0.3937 | 9.80 | 10.00 | 3 |
| E | 0.1497 | 0.1574 | 3.80 | 4.00 | 4 |
| e | 0.050 BSC | | 1.27 BSC | | - |
| H | 0.2284 | 0.2440 | 5.80 | 6.20 | - |
| h | 0.0099 | 0.0196 | 0.25 | 0.50 | 5 |
| L | 0.016 | 0.050 | 0.40 | 1.27 | 6 |
| N | 16 | | 16 | | 7 |
| α | 0° | 8° | 0° | 8° | - |

NOTES:

1. Symbols are defined in the "MO Series Symbol List" in Section 2.2 of Publication Number 95.
2. Dimensioning and tolerancing per ANSI Y14.5M-1982.
3. Dimension "D" does not include mold flash, protrusions or gate burrs. Mold flash, protrusion and gate burrs shall not exceed 0.15mm (0.006 inch) per side.
4. Dimension "E" does not include interlead flash or protrusions. Interlead flash and protrusions shall not exceed 0.25mm (0.010 inch) per side.
5. The chamfer on the body is optional. If it is not present, a visual index feature must be located within the crosshatched area.
6. "L" is the length of terminal for soldering to a substrate.
7. "N" is the number of terminal positions.
8. Terminal numbers are shown for reference only.
9. The lead width "B", as measured 0.36mm (0.014 inch) or greater above the seating plane, shall not exceed a maximum value of 0.61mm (0.024 inch).
10. Controlling dimension: MILLIMETER. Converted inch dimensions are not necessarily exact.

Rev. 1 6/05

All Intersil U.S. products are manufactured, assembled and tested utilizing ISO9000 quality systems. Intersil Corporation's quality certifications can be viewed at www.intersil.com/design/quality

Intersil products are sold by description only. Intersil Corporation reserves the right to make changes in circuit design, software and/or specifications at any time without notice. Accordingly, the reader is cautioned to verify that data sheets are current before placing orders. Information furnished by Intersil is believed to be accurate and reliable. However, no responsibility is assumed by Intersil or its subsidiaries for its use; nor for any infringements of patents or other rights of third parties which may result from its use. No license is granted by implication or otherwise under any patent or patent rights of Intersil or its subsidiaries.

For information regarding Intersil Corporation and its products, see www.intersil.com