

## Excellent Integrated System Limited

Stocking Distributor

Click to view price, real time Inventory, Delivery & Lifecycle Information:

[STMicroelectronics](#)  
[ST2378ETTR](#)

For any questions, you can email us directly:

[sales@integrated-circuit.com](mailto:sales@integrated-circuit.com)



# ST2378E

## 8-bit dual supply 1.71 V to 5.5 V level translator with I/O $V_{CC} \pm 15$ kV ESD protection

Datasheet - production data

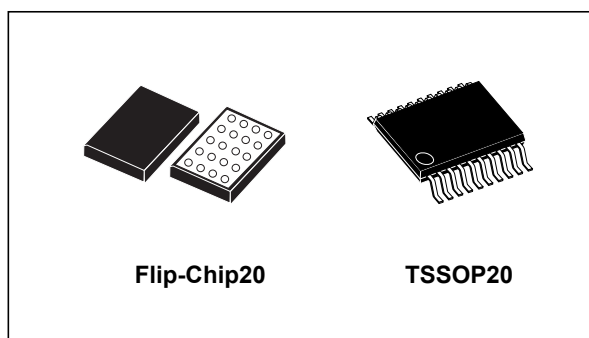

### Description

The ST2378E device is an 8-bit, dual supply, bidirectional level translator with  $\pm 15$  kV ESD protection on I/Os at  $V_{CC}$  side. It is designed to interface data transfer between low voltage ASICs/PLDs and higher voltage systems. Externally applied voltage,  $V_{CC}$  and  $V_L$ , set logic levels at both sides with the range specified as  $1.71 \text{ V} \leq V_L \leq 5.5 \text{ V}$  and  $V_L \leq V_{CC} \leq 5.5 \text{ V}$ . For proper operation,  $V_{CC}$  should be set higher than  $V_L$ .

Utilizing a transmission-gate-based design, this device allows bidirectional asynchronous data transfer, which means each channel is allowed to have either  $V_{CC}$  to  $V_L$  or  $V_L$  to  $V_{CC}$  data transfer direction independently and no direction pin is required. The ST2378E device operates at a guaranteed data rate of 13 Mbps over the entire specified operating voltage range.

Among the other features, the OE pin allows disable mode operation whereby current consumption is reduced to less than  $1 \mu\text{A}$ .

### Features

- High speed
  - $t_{PD} = 15 \text{ ns}$  (max.) at  $T_A = 85 \text{ }^\circ\text{C}$
  - $V_L = 1.8 \text{ V}$
  - $V_{CC} = 5.5 \text{ V}$
- Guaranteed data rate
  - 13 Mbps ( $1.8 \text{ V} \leq V_L \leq V_{CC} \leq 5.5 \text{ V}$ )
- Low power dissipation
  - $I_{TS-VL} = I_{TS-VCC} = 1 \mu\text{A}$  (max.) at  $T_A = 85 \text{ }^\circ\text{C}$
  - $I_{QVL} = 100 \mu\text{A}$  (max.) at  $T_A = 85 \text{ }^\circ\text{C}$
  - $I_{QCC} = 10 \mu\text{A}$  (max.) at  $T_A = 85 \text{ }^\circ\text{C}$
- Output impedance
  - $|I_{OHA}| = 20 \mu\text{A}$  (min.) at  $V_L = 1.8 \text{ V}; V_{CC} = 5.5 \text{ V}$
  - $I_{OLA} = 1.0 \mu\text{A}$  (min.) at  $V_L = 1.8 \text{ V}; V_{CC} = 5.5 \text{ V}$
- Bidirectional level translation
- Totem pole and open drain driving for I<sup>2</sup>C communications
- 5 V tolerant on enable pin
- Wide operating voltage range
  - $V_L$  (opr.) = 1.71 V to  $V_{CC}$
  - $V_{CC}$  (opr.) = 1.71 V to 5.5 V
- ESD performance
- HBM > 15 kV ESD protection on I/O  $V_{CC}$  lines
- Lead-free Flip-Chip and TSSOP package

Table 1. Device summary

Part number	Temp. range (°C)	Package	Marking
ST2378EBJR	-40 to 85	Flip-Chip20	ST2378E
ST2378ETTR	-40 to 85	TSSOP20	ST2378E

## Contents

<b>1</b>	<b>Block diagram</b> .....	<b>3</b>
<b>2</b>	<b>Pin settings</b> .....	<b>4</b>
2.1	Pin connection .....	4
2.2	Pin description .....	4
<b>3</b>	<b>Electrical data</b> .....	<b>5</b>
3.1	Maximum ratings .....	5
3.2	Recommended operating conditions .....	5
<b>4</b>	<b>Electrical characteristics</b> .....	<b>6</b>
<b>5</b>	<b>Test circuit</b> .....	<b>11</b>
<b>6</b>	<b>Waveforms</b> .....	<b>12</b>
<b>7</b>	<b>Package information</b> .....	<b>14</b>
7.1	TSSOP20 package information .....	15
7.2	TSSOP20 packing information .....	16
7.3	Flip-Chip20 package information .....	17
7.4	Flip-Chip20 packing information .....	18
<b>8</b>	<b>Revision history</b> .....	<b>19</b>

# 1 Block diagram

Figure 1. Block diagram

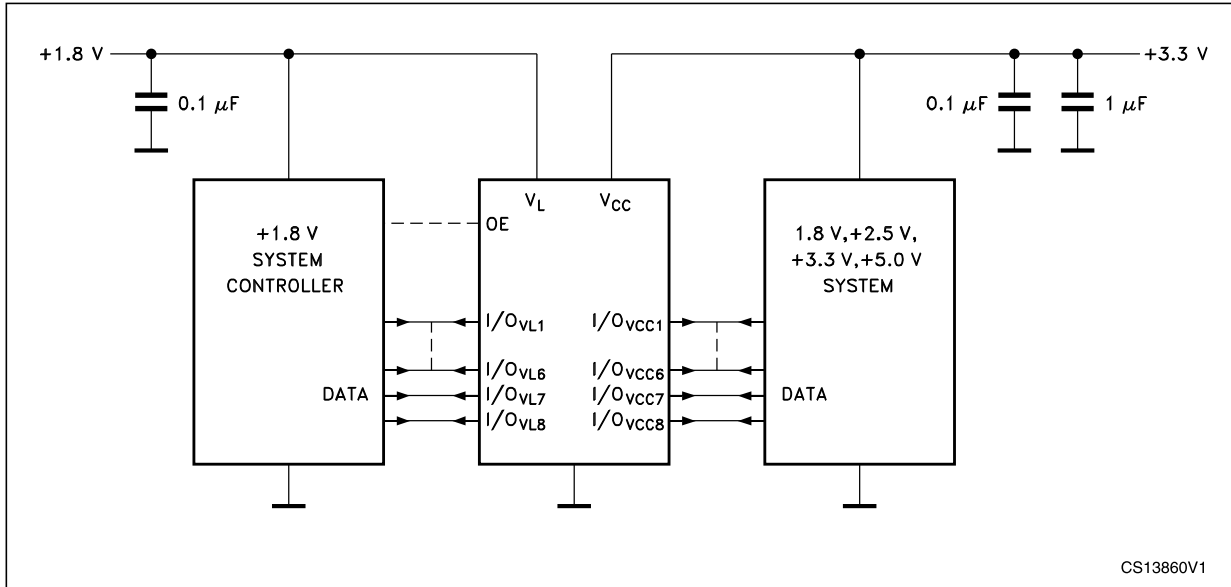
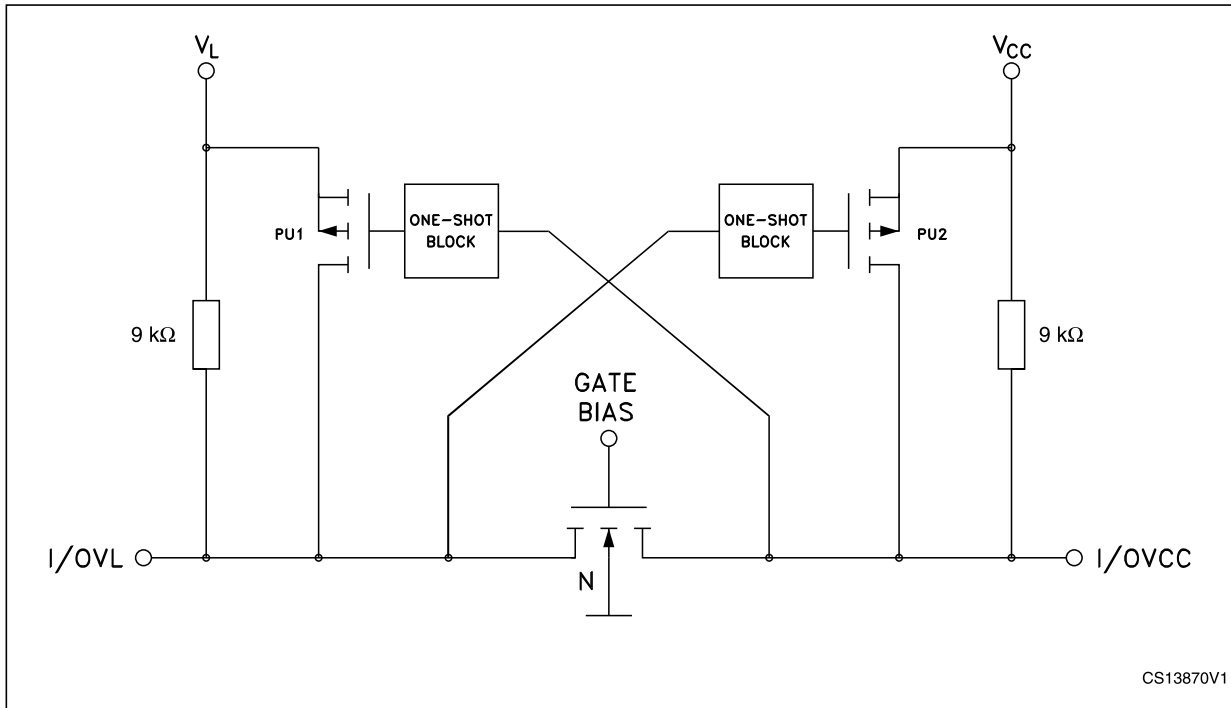

Figure 2. Functional diagram (1 I/O line)



## 2 Pin settings

### 2.1 Pin connection

Figure 3. Pin connection

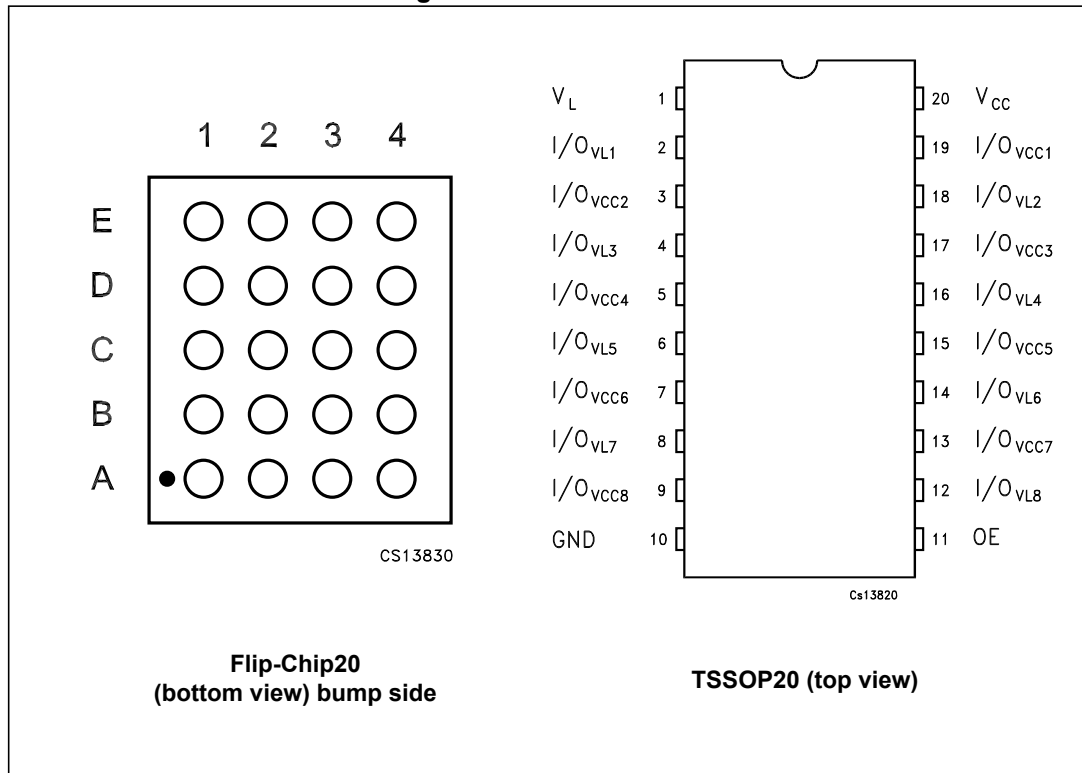

### 2.2 Pin description

Table 2. Pin description

Flip-Chip20 pin N°	TSSOP20 pin N°	Symbol	Name and function
E2, D1, D2, C1, C2, B1, B2, A1	2, 18, 4, 16, 6, 14, 8, 12	$I/O_{VL1}$ to $I/O_{VL8}$	Data inputs/outputs
E3, D4, D3, C4, C3, B4, B3, A4	19, 3, 17, 5, 15, 7, 13, 9	$I/O_{VCC1}$ to $I/O_{VCC8}$	Data inputs/outputs
A2	11	OE	Output enable inputs
A3	10	GND	Ground (0 V)
E1	1	$V_L$	Positive supply voltage
E4	20	$V_{CC}$	Positive supply voltage

### 3 Electrical data

#### 3.1 Maximum ratings

Table 3. Absolute maximum rating

Symbol	Parameter	Value	Unit
$V_L$	Supply voltage	-0.3 to $V_{CC}$	V
$V_{CC}$	Supply voltage	-0.3 to +7.0	V
$V_{OE}$	DC control input voltage	-0.3 to +7.0	V
$V_{I/OVL}$	DC $I/O_{VL}$ input voltage (OE = GND or $V_L$ )	-0.3 to $V_L + 0.3$	V
$V_{I/OVCC}$	DC $I/O_{VCC}$ input voltage (OE = GND or $V_L$ )	-0.3 to $V_{CC} + 0.3$	V
$I_{IK}$	DC input diode current (OE control pin)	- 20	mA
$I_{IOVL}$	DC output current	± 25	mA
$I_{IOVCC}$	DC output current	± 25	mA
$I_{SCTOUT}$	Short-circuit duration $I/O_{VL}$ , $I/O_{VCC}$ driven from 40 mA source	Continuous	mA
$I_{CCB}$	DC $V_{CC}$ or ground current	± 100	mA
$P_d$	Power dissipation <sup>(1)</sup>	500	mW
$T_{stg}$	Storage temperature	-65 to +150	°C
$T_L$	Lead temperature (10 sec.)	300	°C

1. 500 mW: ≅ 65 °C derated to 300 mW by 10 mW/°C: 65 °C to 85 °C.

#### 3.2 Recommended operating conditions

Table 4. Recommended operating conditions

Symbol	Parameter	Value	Unit	
$V_L$	Supply voltage	1.71 to $V_{CC}$	V	
$V_{CC}$	Supply voltage	1.71 to 5.5	V	
$V_I$	Input voltage (OE output enable pin, $V_L$ power supply referred)	0 to 5.5	V	
$V_{I/OVL}$	$I/O_{VL}$ voltage	0 to $V_L$	V	
$V_{I/OVCC}$	$I/O_{VCC}$ voltage	0 to $V_{CC}$	V	
$T_{op}$	Operating temperature	-40 to 85	°C	
dt/dv	Input rise and fall time (OE control pin) <sup>(1)</sup>	0 to 10	ns/V	
dt/dv	Input rise and fall time <sup>(2)</sup>	$1.71 < V_L < V_{CC} < 5 V$	0 to 10	ns/V
		$V_{CC} = V_L = 5 V$	0 to 3	ns/V

1.  $V_{OE}$  from 10%  $V_L$  to 90%  $V_L$ .

2.  $V_{IOVL}$  from 10%  $V_L$  to 90%  $V_L$ ;  $V_{IOVCC}$  from 10%  $V_{CC}$  to 90%  $V_{CC}$ .

Electrical characteristics

ST2378E

## 4 Electrical characteristics

Table 5. DC specification

Symbol	Parameter	Test condition <sup>(1)</sup>			Value					Unit
		V <sub>L</sub> (V) <sup>(2)</sup>	V <sub>CC</sub> (V) <sup>(2)</sup>		T <sub>A</sub> = 25 °C			-40 to 85 °C		
					Min.	Typ. <sup>(3)</sup>	Max.	Min.	Max.	
V <sub>IHL</sub>	High level input voltage (I/O <sub>VL</sub> )	1.8	V <sub>L</sub> to 5.5		V <sub>L</sub> -0.2			V <sub>L</sub> -0.2		V
		2.5	V <sub>L</sub> to 5.5		0.75 V <sub>L</sub>			0.75 V <sub>L</sub>		
		3.3	V <sub>L</sub> to 5.5		0.75 V <sub>L</sub>			0.75 V <sub>L</sub>		
		5.0	V <sub>L</sub> to 5.5		0.75 V <sub>L</sub>			0.75 V <sub>L</sub>		
V <sub>ILL</sub>	Low level input voltage (I/O <sub>VL</sub> )	1.8	V <sub>L</sub> to 5.5				0.15		0.15	V
		2.5	V <sub>L</sub> to 5.5				0.30		0.30	
		3.3	V <sub>L</sub> to 5.5				0.30		0.30	
		5.0	V <sub>L</sub> to 5.5				0.30		0.30	
V <sub>IHC</sub>	High level input voltage (I/O <sub>VCC</sub> )	1.8	V <sub>L</sub> to 5.5		V <sub>L</sub> -0.2			V <sub>L</sub> -0.2		V
		2.5	V <sub>L</sub> to 5.5		0.75 V <sub>CC</sub>			0.75 V <sub>CC</sub>		
		3.3	V <sub>L</sub> to 5.5		0.75 V <sub>CC</sub>			0.75 V <sub>CC</sub>		
		5.0	V <sub>L</sub> to 5.5		0.75 V <sub>CC</sub>			0.75 V <sub>CC</sub>		
V <sub>ILC</sub>	Low level input voltage (I/O <sub>VCC</sub> )	1.8	V <sub>L</sub> to 5.5				0.15		0.15	V
		2.5	V <sub>L</sub> to 5.5				0.30		0.30	
		3.3	V <sub>L</sub> to 5.5				0.30		0.30	
		5.0	V <sub>L</sub> to 5.5				0.30		0.30	
V <sub>IH-TS</sub>	High level input voltage (OE)	1.8	V <sub>L</sub> to 5.5		V <sub>L</sub> -0.2			V <sub>L</sub> -0.2		V
		2.5	V <sub>L</sub> to 5.5		0.75 V <sub>L</sub>			0.75 V <sub>L</sub>		
		3.3	V <sub>L</sub> to 5.5		0.75 V <sub>L</sub>			0.75 V <sub>L</sub>		
		5.0	V <sub>L</sub> to 5.5		0.75 V <sub>L</sub>			0.75 V <sub>L</sub>		
V <sub>IL-TS</sub>	Low level input voltage (OE)	1.8	V <sub>L</sub> to 5.5				0.15		0.15	V
		2.5	V <sub>L</sub> to 5.5				0.25 V <sub>L</sub>		0.25 V <sub>L</sub>	
		3.3	V <sub>L</sub> to 5.5				0.25 V <sub>L</sub>		0.25 V <sub>L</sub>	
		5.0	V <sub>L</sub> to 5.5				0.25 V <sub>L</sub>		0.25 V <sub>L</sub>	
V <sub>OHL</sub>	High level output voltage I/O <sub>VL</sub>	1.8 to 5.5	V <sub>L</sub> to 5.5	I <sub>O</sub> = -20 μA I/O <sub>VCC</sub> ≥ V <sub>CC</sub> - 0.2	0.67 V <sub>L</sub>			0.67 V <sub>L</sub>		V
V <sub>OLL</sub>	Low level output voltage I/O <sub>VL</sub>			I <sub>O</sub> = 1.0 mA I/O <sub>VCC</sub> ≤ 0.15 V			0.40		0.40	

ST2378E

Electrical characteristics

Table 5. DC specification (continued)

Symbol	Parameter	Test condition <sup>(1)</sup>			Value					Unit
		V <sub>L</sub> (V) <sup>(2)</sup>	V <sub>CC</sub> (V) <sup>(2)</sup>		T <sub>A</sub> = 25 °C			-40 to 85 °C		
					Min.	Typ. <sup>(3)</sup>	Max.	Min.	Max.	
V <sub>OHC</sub>	High level output voltage I/O <sub>VCC</sub>	1.8 to 5.5	V <sub>L</sub> to 5.5	I <sub>O</sub> = -20 μA I/O <sub>VL</sub> ≥ V <sub>L</sub> - 0.2	0.67 V <sub>CC</sub>			0.67 V <sub>CC</sub>		V
V <sub>OLC</sub>	Low level output voltage I/O <sub>VCC</sub>			I <sub>O</sub> = 1.0 mA I/O <sub>VL</sub> ≤ 0.15 V			0.40		0.40	
I <sub>TSL</sub>	Control input leakage current (OE)	1.8 to 5.5	V <sub>L</sub> to 5.5	V <sub>I</sub> = GND or 5.5			1		1	μA
I <sub>TS-LKG</sub>	High impedance input leakage current (I/O <sub>VL</sub> , I/O <sub>VCC</sub> )	1.8 to 5.5	V <sub>L</sub> to 5.5	OE = GND			1		1	μA
I <sub>QVCC</sub>	Quiescent supply current V <sub>CC</sub>	1.8 to 5.5	V <sub>L</sub> to 5.5	I/O <sub>VL</sub> , I/O <sub>VCC</sub> unconnected		0.1	1		10	μA
I <sub>QVL</sub>	Quiescent supply current V <sub>L</sub>	1.8 to 5.5	V <sub>L</sub> to 5.5	I/O <sub>VL</sub> , I/O <sub>VCC</sub> unconnected		13	20		100	μA
I <sub>TS-VL</sub>	High impedance mode quiescent supply current V <sub>L</sub>	1.8 to 5.5	V <sub>L</sub> to 5.5	OE = GND I/O <sub>VL</sub> = GND to V <sub>L</sub> I/O <sub>VCC</sub> = GND to V <sub>CC</sub>			1		1	μA

1. For normal operation, ensure V<sub>L</sub> < (V<sub>CC</sub> + 0.3 V). During power-up, V<sub>L</sub> > (V<sub>CC</sub> + 0.3 V) will not damage the device.
2. Power supply range: V<sub>L</sub>, V<sub>CC</sub> 1.8 V ± 5%, 2.5 ± 0.2 V, 3.3 ± 0.3 V, 5.0 ± 0.5 V.
3. Typical values are referred to T<sub>A</sub> = 25 °C.



Electrical characteristics

ST2378E

Table 6. AC electrical characteristics (totem pole driving)

Symbol	Parameter	Test condition <sup>(1)</sup>		Value			Unit	
		C <sub>L</sub> = 15 pF, t <sub>r</sub> = t <sub>f</sub> ≤ 6 ns <sup>(2)</sup> Driver output R <sub>T</sub> ≤ 50 Ω		-40 to +85 °C				
		V <sub>L</sub> (V) <sup>(3)</sup>	V <sub>CC</sub> (V) <sup>(3)</sup>	Min.	Typ. <sup>(4)</sup>	Max.		
t <sub>RVCC</sub>	Rise time I/O <sub>VCC</sub> <sup>(5)</sup>	1.8	1.8		11	15	ns	
		1.8	2.5		11	15		
		1.8	3.3		10	15		
		1.8	5.0		9	15		
		2.5	3.3		8	15		
t <sub>FVCC</sub>	Fall time I/O <sub>VCC</sub> <sup>(5)</sup>	1.8	1.8		6	15	ns	
		1.8	2.5		7	15		
		1.8	3.3		8	15		
		1.8	5.0		10	15		
		2.5	3.3		6	15		
t <sub>RVL</sub>	Rise time I/O <sub>VL</sub> <sup>(5)</sup>	1.8	1.8		12	15	ns	
		1.8	2.5		10	15		
		1.8	3.3		9	15		
		1.8	5.0		10	15		
		2.5	3.3		7	15		
t <sub>FVL</sub>	Fall time I/O <sub>VL</sub> <sup>(5)</sup>	1.8	1.8		7	15	ns	
		1.8	2.5		6	15		
		1.8	3.3		6	15		
		1.8	5.0		7	15		
		2.5	3.3		4	15		
t <sub>IOVL-VCC</sub>	Propagation delay time <sup>(6)</sup> I/O <sub>VL</sub> -LH to I/O <sub>VCC</sub> -LH I/O <sub>VL</sub> -HL to I/O <sub>VCC</sub> -HL	t <sub>PLH</sub>	1.8	1.8		6	15	ns
			1.8	2.5		7	15	
			1.8	3.3		7	15	
			1.8	5.0		7	15	
			2.5	3.3		4	15	
		t <sub>PHL</sub>	1.8	1.8		5	15	
			1.8	2.5		5	15	
			1.8	3.3		6	15	
			1.8	5.0		8	15	
			2.5	3.3		4	15	

ST2378E

Electrical characteristics

Table 6. AC electrical characteristics (totem pole driving) (continued)

Symbol	Parameter	Test condition <sup>(1)</sup>		Value			Unit	
		C <sub>L</sub> = 15 pF, t <sub>r</sub> = t <sub>f</sub> ≤ 6 ns <sup>(2)</sup> Driver output R <sub>T</sub> ≤ 50 Ω		-40 to +85 °C				
		V <sub>L</sub> (V) <sup>(3)</sup>	V <sub>CC</sub> (V) <sup>(3)</sup>	Min.	Typ. <sup>(4)</sup>	Max.		
t <sub>IOVCC-VL</sub>	Propagation delay time <sup>(6)</sup> I/O <sub>VCC-LH</sub> to I/O <sub>VL-LH</sub> I/O <sub>VCC-HL</sub> to I/O <sub>VL-HL</sub>	t <sub>PLH</sub>	1.8	1.8		2	15	ns
			1.8	2.5		2	15	
			1.8	3.3		2	15	
			1.8	5.0		2	15	
			2.5	3.3		2	15	
		t <sub>PHL</sub>	1.8	1.8		5	15	
			1.8	2.5		5	15	
			1.8	3.3		5	15	
			1.8	5.0		6	15	
			2.5	3.3		4	15	
t <sub>PZL</sub> t <sub>PZH</sub> t <sub>PLZ</sub> t <sub>PZL</sub>	Output enable and disable time	1.8	1.8		60	80	ns	
1.8	5.0		150	200				
t <sub>OSLH</sub> t <sub>OSHL</sub>	Channel to channel skew time <sup>(7),(8)</sup>	1.8	1.8		0.1	1	ns	
1.8	5.0		0.5	1				
DR	Maximum data rate	1.8 to 5.0	V <sub>L</sub> to 5.0	13			Mbps	

- For normal operation, ensure V<sub>L</sub> < (V<sub>CC</sub> + 0.3 V). During power-up, V<sub>L</sub> > (V<sub>CC</sub> + 0.3 V) will not damage the device.
- For V<sub>CC</sub> = V<sub>L</sub> = 1.8 V, t<sub>r</sub> = t<sub>f</sub> ≤ 4 ns.
- Power supply range: V<sub>L</sub>, V<sub>CC</sub> 1.8 V ± 5%, 2.5 ± 0.2 V, 3.3 ± 0.3 V, 5.0 ± 0.5 V.
- Typical values are referred to T<sub>A</sub> = 25 °C.
- Rise time: 10% to 90%, fall time 90% to 10%.
- Propagation delay time: 50% to 50%.
- Skew is defined as the absolute value of the difference between the actual propagation delay for any two outputs of the same device switching in the same direction, either HIGH or LOW (t<sub>OSLH</sub> = |t<sub>PLHm</sub> - t<sub>PLHn</sub>|, t<sub>OSHL</sub> = |t<sub>PHLm</sub> - t<sub>PHLn</sub>|).
- Each translator equally loaded; parameter guaranteed by design.

Electrical characteristics

ST2378E

Table 7. AC characteristic (open drain driving)

Symbol	Parameter	Test condition <sup>(1)</sup>		Value			Unit	
		C <sub>L</sub> = 15 pF, t <sub>r</sub> = t <sub>f</sub> ≤ 6 ns <sup>(2)</sup> Driver output R <sub>T</sub> ≤ 50 Ω		-40 to +85 °C				
		V <sub>L</sub> (V) <sup>(3)</sup>	V <sub>CC</sub> (V) <sup>(3)</sup>	Min.	Typ. <sup>(4)</sup>	Max.		
t <sub>RVCC</sub>	Rise time I/O <sub>VCC</sub> <sup>(5)</sup>	1.8	1.8		210	300	ns	
		1.8	5.0		59	150		
t <sub>FVCC</sub>	Fall time I/O <sub>VCC</sub> <sup>(5)</sup>	1.8	1.8		12	30	ns	
		1.8	5.0		20	30		
t <sub>RVL</sub>	Rise time I/O <sub>VL</sub> <sup>(5)</sup>	1.8	1.8		210	300	ns	
		1.8	5.0		96	150		
t <sub>FVL</sub>	Fall time I/O <sub>VL</sub> <sup>(5)</sup>	1.8	1.8		11	30	ns	
		1.8	5.0		11	30		
t <sub>IOVL-VCC</sub>	Propagation delay time <sup>(6)</sup> I/O <sub>VL-LH</sub> to I/O <sub>VCC-LH</sub> I/O <sub>VL-HL</sub> to I/O <sub>VCC-HL</sub>	t <sub>PLH</sub>	1.8	1.8		210	300	ns
			1.8	5.0		100	150	
		t <sub>PHL</sub>	1.8	1.8		7	20	
			1.8	5.0		14	20	
t <sub>IOVCC-VL</sub>	Propagation delay time <sup>(6)</sup> I/O <sub>VCC-LH</sub> to I/O <sub>VL-LH</sub> I/O <sub>VCC-HL</sub> to I/O <sub>VL-HL</sub>	t <sub>PLH</sub>	1.8	1.8		210	300	ns
			1.8	5.0		57	150	
		t <sub>PHL</sub>	1.8	1.8		7	20	
			1.8	5.0		8	20	
t <sub>PZL</sub> t <sub>PZH</sub> t <sub>PLZ</sub> t <sub>PZL</sub>	Output enable and disable time	1.8	1.8		60	80	ns	
		1.8	5.0		150	200		
t <sub>OSLH</sub> t <sub>OSHL</sub>	Channel to channel skew time <sup>(7),(8)</sup>	1.8	1.8		10	20	ns	
		1.8	5.0		2	10		
DR	Maximum data rate	1.8 to 5.0	V <sub>L</sub> to 5.0	800			kbps	

- For normal operation, ensure V<sub>L</sub> < (V<sub>CC</sub> + 0.3 V). During power-up, V<sub>L</sub> > (V<sub>CC</sub> + 0.3 V) will not damage the device.
- For V<sub>CC</sub> = V<sub>L</sub> = 1.8 V, t<sub>r</sub> = t<sub>f</sub> ≤ 4 ns.
- Power supply range: V<sub>L</sub>, V<sub>CC</sub> 1.8 V ± 5%, 2.5 ± 0.2 V, 3.3 ± 0.3 V, 5.0 ± 0.5 V.
- Typical values are referred to T<sub>A</sub> = 25 °C.
- Rise time: 10% to 90%, fall time 90% to 10%.
- Propagation delay time: 50% to 50%.
- Skew is defined as the absolute value of the difference between the actual propagation delay for any two outputs of the same device switching in the same direction, either HIGH or LOW (t<sub>OSLH</sub> = |t<sub>PLHm</sub> - t<sub>PLHn</sub>|, t<sub>OSHL</sub> = |t<sub>PHLm</sub> - t<sub>PHLn</sub>|).
- Each translator equally loaded; parameter guaranteed by design.

## 5 Test circuit

Figure 4. Test circuit

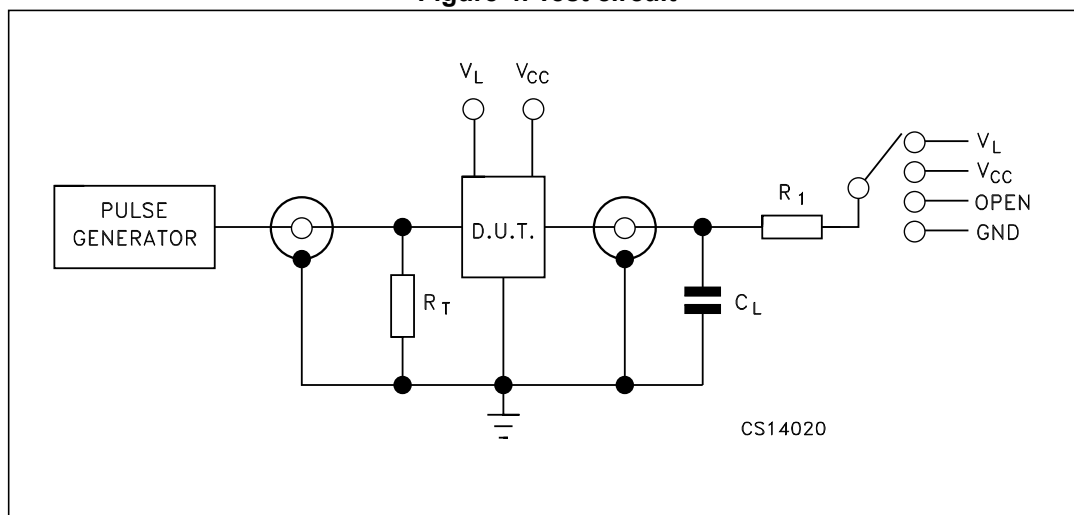

Table 8. Test circuit switches

Test	Switch		
	Driving I/O <sub>V<sub>L</sub></sub>	Driving I/O <sub>V<sub>CC</sub></sub>	Open drain driving
$t_{PLH}$ , $t_{PHL}$	Open	Open	Open
$t_{PZL}$ , $t_{PLZ}$	V <sub>CC</sub>	V <sub>L</sub>	-
$t_{PZH}$ , $t_{PHZ}$	GND	GND	-

Note:  $C_L = 15/50$  pF or equivalent (includes jig and probe capacitance).

$R_1 = 1$  k $\Omega$  or equivalent.

$R_T = Z_{OUT}$  of pulse generator (typically 50  $\Omega$ ).

Table 9. Truth table

Control pin	Bidirectional input/outputs	
OE	I/O <sub>V<sub>L</sub></sub>	I/O <sub>V<sub>CC</sub></sub>
H <sup>(1)</sup>	H <sup>(1)</sup>	H <sup>(2)</sup>
H <sup>(1)</sup>	L	L
L	Z	Z

1. High level V<sub>L</sub> power supply referred.

2. High level V<sub>CC</sub> power supply referred.

Note: X = do not care; Z = high impedance.

## 6 Waveforms

Table 10. Waveform symbol value

Symbol	Driving I/O <sub>VL</sub>		Driving I/O <sub>VCC</sub>	
	1.8 V ≤ V <sub>L</sub> ≤ V <sub>CC</sub> ≤ 2.5 V	3.3 V ≤ V <sub>L</sub> ≤ V <sub>CC</sub> ≤ 5.0 V	1.8 V ≤ V <sub>L</sub> ≤ V <sub>CC</sub> ≤ 2.5 V	3.3 V ≤ V <sub>L</sub> ≤ V <sub>CC</sub> ≤ 5.0 V
V <sub>IH</sub>	V <sub>L</sub>	V <sub>L</sub>	V <sub>CC</sub>	V <sub>CC</sub>
V <sub>IM</sub>	50% V <sub>L</sub>	50% V <sub>L</sub>	50% V <sub>CC</sub>	50% V <sub>CC</sub>
V <sub>OM</sub>	50% V <sub>CC</sub>	50% V <sub>CC</sub>	50% V <sub>CC</sub>	50% V <sub>CC</sub>
V <sub>X</sub>	V <sub>OL</sub> + 0.15 V	V <sub>OL</sub> + 0.3 V	V <sub>OL</sub> + 0.15 V	V <sub>OL</sub> + 0.3 V
V <sub>Y</sub>	V <sub>OH</sub> - 0.15 V	V <sub>OH</sub> - 0.3 V	V <sub>OH</sub> - 0.15 V	V <sub>OH</sub> - 0.3 V

Figure 5. Waveform - propagation delay (f = 1 MHz; 50% duty cycle)

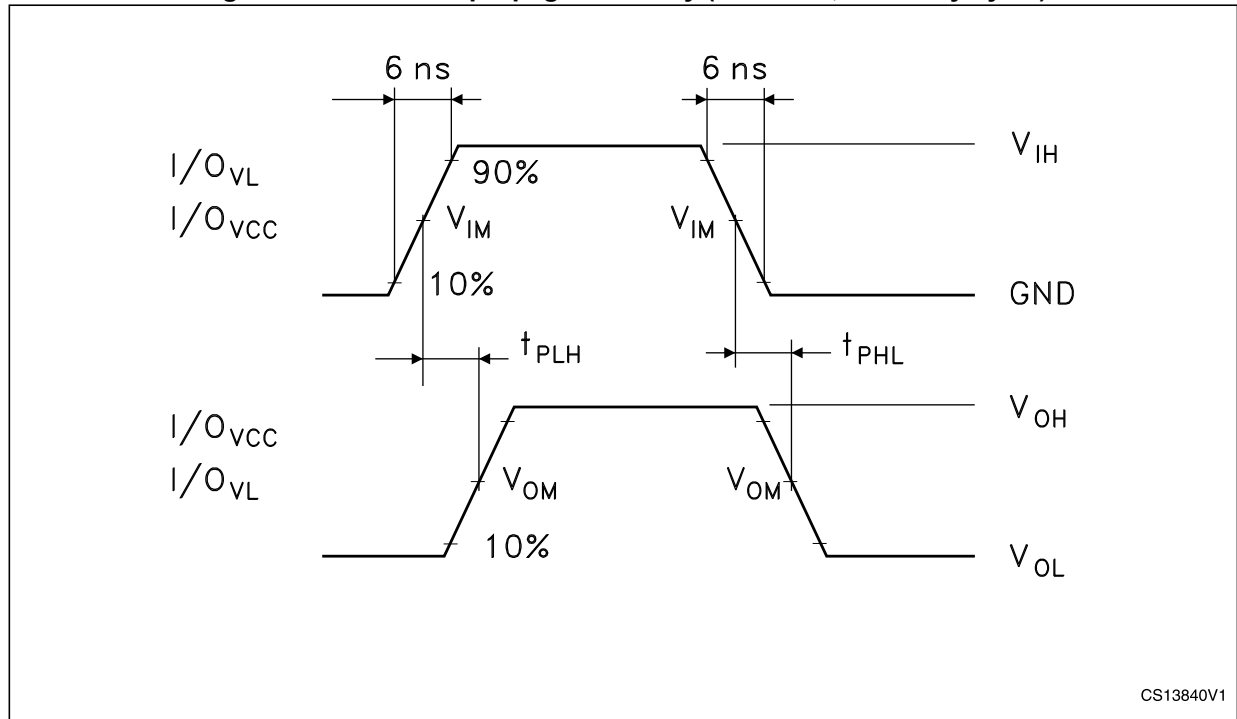

CS13840V1

ST2378E

Waveforms

Figure 6. Waveform - output enable and disable time (f = 1 MHz; 50% duty cycle)

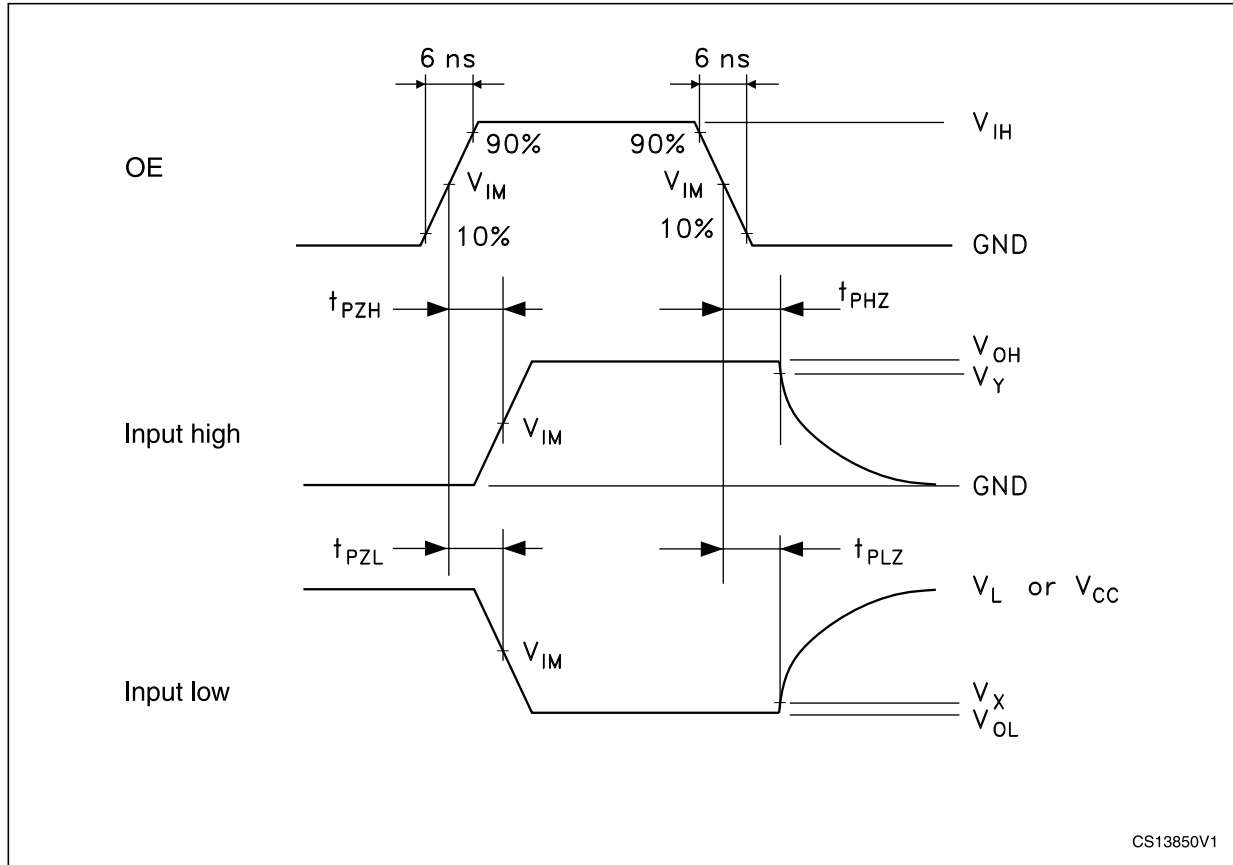

## 7 Package information

In order to meet environmental requirements, ST offers these devices in different grades of ECOPACK<sup>®</sup> packages, depending on their level of environmental compliance. ECOPACK specifications, grade definitions and product status are available at: [www.st.com](http://www.st.com). ECOPACK is an ST trademark.

## 7.1 TSSOP20 package information

Figure 7. TSSOP20 package outline

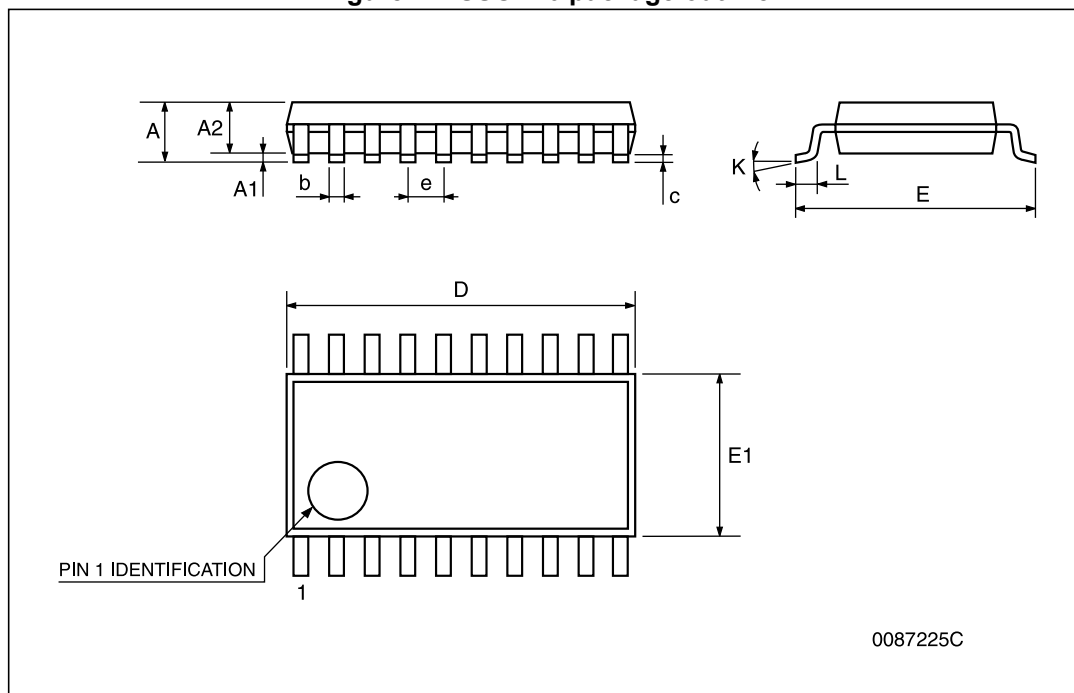

Table 11. TSSOP20 package mechanical data

Symbol	Dimensions					
	mm			inch		
	Min.	Typ.	Max.	Min.	Typ.	Max.
A			1.2			0.047
A1	0.05		0.15	0.002	0.004	0.006
A2	0.8	1	1.05	0.031	0.039	0.041
b	0.19		0.30	0.007		0.012
c	0.09		0.20	0.004		0.0079
D	6.4	6.5	6.6	0.252	0.256	0.260
E	6.2	6.4	6.6	0.244	0.252	0.260
E1	4.3	4.4	4.48	0.169	0.173	0.176
e		0.65 BSC			0.0256 BSC	
K	0°		8°	0°		8°
L	0.45	0.60	0.75	0.018	0.024	0.030



## 7.2 TSSOP20 packing information

Figure 8. TSSOP20 tape and reel outline

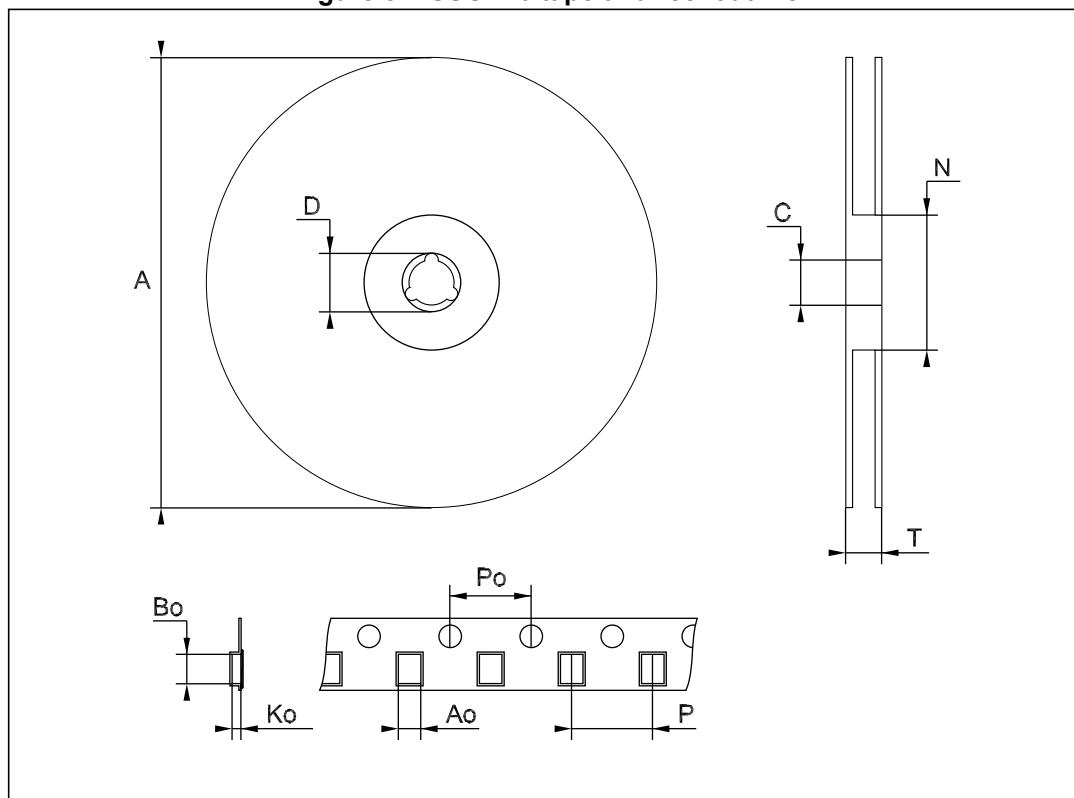

1. Drawing not to scale.

Table 12. TSSOP20 tape and reel mechanical data

Symbol	Dimensions					
	mm			inch		
	Min.	Typ.	Max.	Min.	Typ.	Max.
A			330			12.992
C	12.8		13.2	0.504		0.519
D	20.2			0.795		
N	60			2.362		
T			22.4			0.882
Ao	6.8		7	0.268		0.276
Bo	6.9		7.1	0.272		0.280
Ko	1.7		1.9	0.067		0.075
Po	3.9		4.1	0.153		0.161
P	11.9		12.1	0.468		0.476

### 7.3 Flip-Chip20 package information

Figure 9. Flip-Chip20 package outline

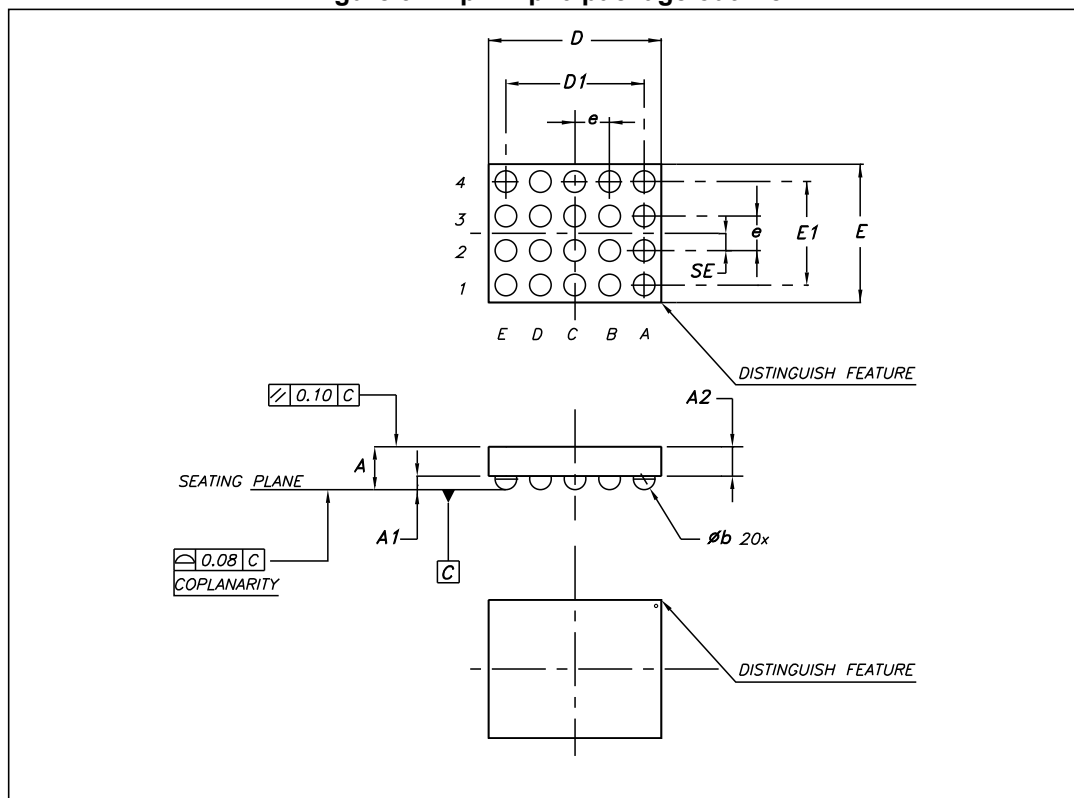
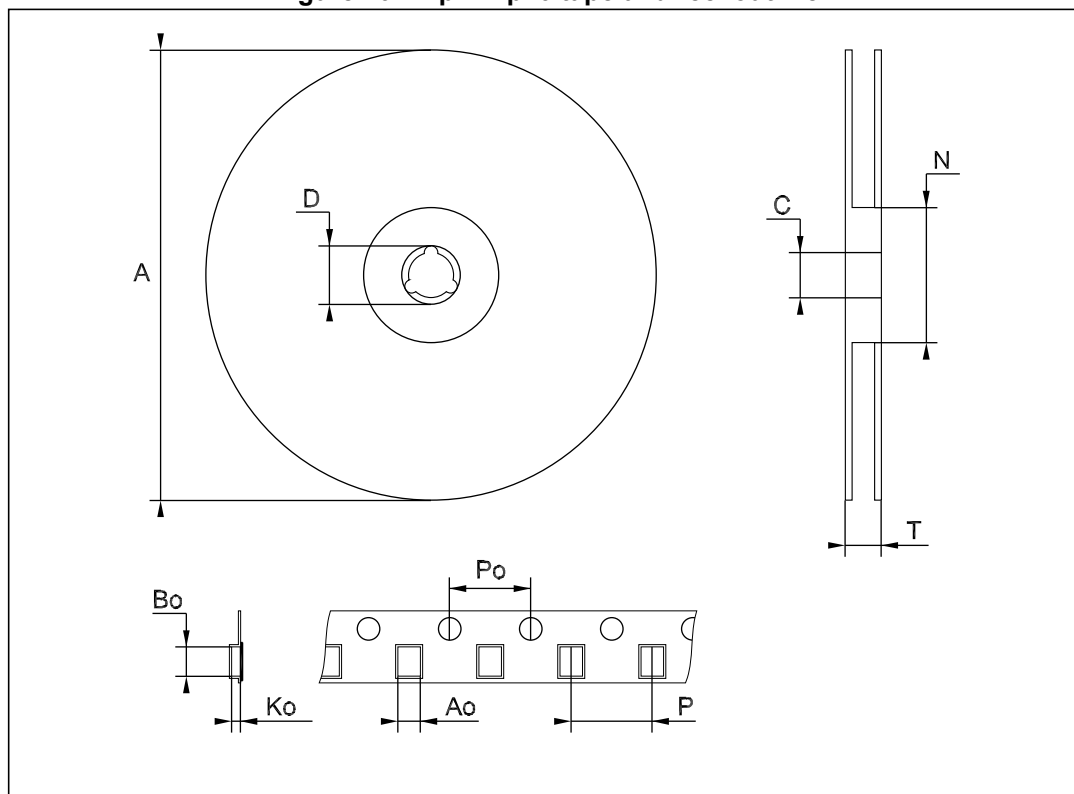

Table 13. Flip-Chip20 package mechanical data

Symbol	Dimensions					
	mm			mils		
	Min.	Typ.	Max.	Min.	Typ.	Max.
A	0.81	0.89	1.00	31.9	35.0	39.4
A1	0.15	0.24	0.35	5.9	9.4	13.8
A2		0.65			25.6	
b	0.25	0.30	0.35	9.8	11.8	13.8
D	2.41	2.46	2.51	94.9	96.9	98.8
D1		2.00			78.7	
E	1.93	1.98	2.03	76.0	78.0	79.9
E1		1.5			59.1	
e		0.50			19.7	
SE		0.25			9.8	

## 7.4 Flip-Chip20 packing information

Figure 10. Flip-Chip20 tape and reel outline



1. Drawing not to scale.

Table 14. Flip-Chip20 tape and reel mechanical data

Symbol	Dimensions					
	mm			inch		
	Min.	Typ.	Max.	Min.	Typ.	Max.
A			180			7.086
C	12.8		13.2	0.504		0.519
D	20.2			0.795		
N	60			2.362		
T			14.4			0.567
Ao	2.13	2.23	2.33	0.084	0.088	0.092
Bo	2.62	2.72	2.82	0.103	0.107	0.111
Ko	1.05	1.15	1.25	0.041	0.045	0.049
Po	3.9		4.1	0.153		0.161
P	3.9		4.1	0.153		0.161

## 8 Revision history

Table 15. Document revision history

Date	Revision	Changes
10-Apr-2006	1	Initial release.
18-Sep-2012	2	Updated <i>Figure 2</i> (added resistor values). Updated notes and cross-references of the notes below <i>Table 5</i> to <i>Table 7</i> , replaced $t_{FCC}$ by $t_{FVCC}$ in <i>Table 6</i> and <i>Table 7</i> . Updated ECOPACK text in <i>Section 7.</i> , reformatted <i>Section 7</i> (added <i>Table 11</i> to <i>Table 14</i> , moved note below <i>Figure 8</i> and <i>Figure 10</i> ). Minor corrections throughout document.
18-May-2015	3	Added <i>Table 1: Device summary</i> . Revised presentation of <i>Section 7: Package information</i> . Minor textual updates.

**IMPORTANT NOTICE – PLEASE READ CAREFULLY**

STMicroelectronics NV and its subsidiaries (“ST”) reserve the right to make changes, corrections, enhancements, modifications, and improvements to ST products and/or to this document at any time without notice. Purchasers should obtain the latest relevant information on ST products before placing orders. ST products are sold pursuant to ST’s terms and conditions of sale in place at the time of order acknowledgement.

Purchasers are solely responsible for the choice, selection, and use of ST products and ST assumes no liability for application assistance or the design of Purchasers’ products.

No license, express or implied, to any intellectual property right is granted by ST herein.

Resale of ST products with provisions different from the information set forth herein shall void any warranty granted by ST for such product.

ST and the ST logo are trademarks of ST. All other product or service names are the property of their respective owners.

Information in this document supersedes and replaces information previously supplied in any prior versions of this document.

© 2015 STMicroelectronics – All rights reserved