

Excellent Integrated System Limited

Stocking Distributor

Click to view price, real time Inventory, Delivery & Lifecycle Information:

[Maxim Integrated](#)
[MAX1615EUK-T](#)

For any questions, you can email us directly:

sales@integrated-circuit.com

19-1225; Rev 3; 9/04



High-Voltage, Low-Power Linear Regulators for Notebook Computers

General Description

The MAX1615/MAX1616 are micropower, SOT23-5 linear regulators that supply always-on, keep-alive power to CMOS RAM and microcontrollers (μ Cs) in systems with high-voltage batteries. Key features include wide input voltage range, low dropout voltage, and low quiescent supply current.

Despite a miserly $8\mu\text{A}$ (max) no-load supply current, the MAX1615/MAX1616 have excellent line-transient response and AC power-supply rejection ratio. They provide a clean, fixed 5V or 3.3V output (MAX1615) or an adjustable 1.24V to 28V output (MAX1616), even when subjected to fast supply-voltage changes that occur during the switchover from battery to AC adapter input power. The space-saving SOT23-5 package has excellent thermal characteristics and tolerates up to 571mW of power dissipation. Fault protection is provided by internal foldback current limiting and thermal-shutdown circuitry. The MAX1615/MAX1616 are now available in lead-free packages.

Applications

- CMOS/RTC Backup Power
- Microcontroller Power
- Notebook Computers
- Smart-Battery Packs
- PDAs and Handy-Terminals
- Battery-Powered Systems

Typical Operating Circuit

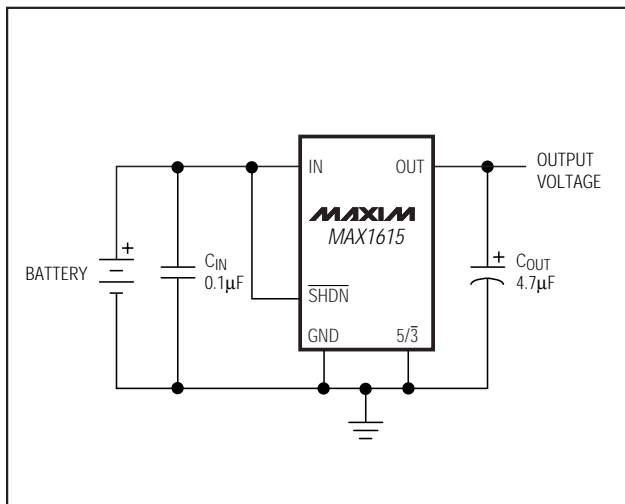

Features

- ◆ 4V to 28V Input Range
- ◆ 8 μA (max) Quiescent Supply Current
- ◆ <1 μA Shutdown Supply Current
- ◆ 3.3V or 5V, Pin-Selectable Output (MAX1615)
Adjustable 1.24V to 28V Output (MAX1616)
- ◆ 30mA Output Current
- ◆ $\pm 2\%$ Initial Output Accuracy
- ◆ Thermal-Overload Protection
- ◆ 5-Pin SOT23 Package
- ◆ Low Cost

MAX1615/MAX1616

Ordering Information

PART	TEMP RANGE	PIN-PACKAGE	SOT TOP MARK
MAX1615EUK-T	-40°C to +85°C	5 SOT23-5	ABZD
MAX1615EUK+T	-40°C to +85°C	5 SOT23-5	ABZD
MAX1616EUK-T	-40°C to +85°C	5 SOT23-5	ABZE
MAX1616EUK+T	-40°C to +85°C	5 SOT23-5	ABZE

+ Denotes lead-free package.

Pin Configuration

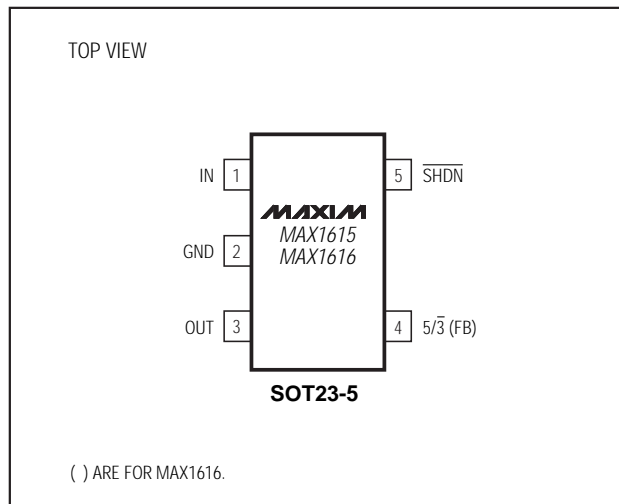

High-Voltage, Low-Power Linear Regulators for Notebook Computers

ABSOLUTE MAXIMUM RATINGS

IN to GND	-0.3V to 30V	Continuous OUT Current.....	40mA
Terminal Voltages to GND		Continuous Power Dissipation (T _A = +70°C) (Note 1)	
SHDN to GND	-0.3V to (V _{IN} + 0.3V)	SOT23-5 (derate 7.1mW/°C above +70°C).....	571mW
5/3 to GND	-0.3V to (V _{OUT} + 0.3V)	Operating Temperature Range	
FB (MAX1616) to GND	-0.3V to (V _{OUT} + 0.3V)	MAX161_EUK-T	-40°C to +85°C
OUT to GND.....	-0.3V to 30V	Storage Temperature Range	-65°C to +160°C
OUT Short-Circuit to GND	30sec	Lead Temperature (soldering, 10s)	+300°C

Note 1: See *Operating Region and Power Dissipation* section.

Stresses beyond those listed under "Absolute Maximum Ratings" may cause permanent damage to the device. These are stress ratings only, and functional operation of the device at these or any other conditions beyond those indicated in the operational sections of the specifications is not implied. Exposure to absolute maximum rating conditions for extended periods may affect device reliability.

ELECTRICAL CHARACTERISTICS

(V_{IN} = 15V, SHDN = V_{IN}, I_{LOAD} = 5μA, T_A = T_{MIN} to T_{MAX}, unless otherwise noted. Typical values are at T_A = +25°C.) (Note 2)

PARAMETER	SYMBOL	CONDITIONS		MIN	TYP	MAX	UNITS
Input Voltage Range	V _{IN}			4		28	V
Supply Current	I _{IN}	SHDN = IN, T _A = +25°C			6.2	8	μA
		SHDN = IN, V _{IN} = 6V to 28V, T _A = T _{MIN} to T _{MAX}				15	
Minimum Load Current						5	μA
Shutdown Supply Current	I _{IN}	SHDN = GND (shutdown mode)	T _A = +25°C			1.5	μA
			T _{MIN} = T _{MIN} to T _{MAX}			3	
Dropout Supply Current		Output set to 5V, V _{IN} = 4V	T _A = +25°C		70		μA
Output Voltage (MAX1615) (Note 3)		I _{LOAD} = 1mA, T _A = +25°C, V _{IN} = 6V to 28V	5/3 = GND	3.26	3.33	3.40	V
			5/3 = OUT	4.95	5.05	5.15	
			5/3 = GND	3.15		3.48	
			5/3 = OUT	4.75		5.25	
FB Threshold (MAX1616) (Note 3)	V _{FBT}	FB = OUT, V _{IN} = 6V to 28V	T _A = +25°C, I _{LOAD} = 1mA	1.215	1.240	1.265	V
			T _A = T _{MIN} to T _{MAX} , I _{LOAD} = 5μA to 30mA	1.18		1.28	
FB Input Current (MAX1616)	I _{FB}	V _{FB} = 1.3V		-10	12	30	nA
Dropout Voltage	ΔV _{DO}	I _{LOAD} = 30mA (Note 4)				350	mV
Output Current Limit		V _{IN} = 6V			100		mA
OUT Reverse Leakage Current		IN = unconnected, V _{OUT} forced to 5V			70		μA
Capacitive Load Requirements (Note 5)		MAX1615		0.16			μF/mA
		MAX1616		0.23			
Start-Up Time Response		Rising edge of IN or SHDN to OUT within specification limits, R _L = 500Ω, C _{OUT} = 6.8μF, V _{OUT} set to 5V				1	ms
Start-Up Overshoot	V _{OSSH}	R _L = 500Ω, C _{OUT} = 10μF within 90% of nominal output voltage			0.5		%V _{OUT}

High-Voltage, Low-Power Linear Regulators for Notebook Computers

ELECTRICAL CHARACTERISTICS (continued)

($V_{IN} = 15V$, $\overline{SHDN} = V_{IN}$, $I_{LOAD} = 5\mu A$, $T_A = T_{MIN}$ to T_{MAX} , unless otherwise noted. Typical values are at $T_A = +25^\circ C$.) (Note 2)

PARAMETER	SYMBOL	CONDITIONS	MIN	TYP	MAX	UNITS
SHDN Input Threshold Voltage	V_{IL}				0.25	V
	V_{IH}		1.4			
SHDN Input Current		$V_{\overline{SHDN}} = 0V$ or $15V$	-1		1	μA
Thermal-Shutdown Temperature	T_{SHDN}	$V_{\overline{SHDN}} = 0V$ or $15V$, hysteresis = $+20^\circ C$		150		$^\circ C$

Note 2: Limits are 100% production tested at $T_A = +25^\circ C$. Limits over the operating temperature range are guaranteed through correlation using standard quality-control (SQC) methods.

Note 3: Pulse tested at $V_{IN} = 28V$, $I_{LOAD} = 30mA$ to avoid exceeding package power-dissipation limits.

Note 4: Guaranteed by design. Tested with V_{OUT} set to 5V. Dropout voltage is tested by reducing the input voltage until V_{OUT} drops to 100mV below its nominal value, measured with V_{IN} starting 2V above V_{OUT} .

Note 5: Use at least 1 μF minimum for light loads. Add 0.125 $\mu F/mA$ (0.2 $\mu F/mA$ for the MAX1616) for loads greater than 100 μA , not production tested. See *Capacitor Selection* in the *Applications Information* section.

Typical Operating Characteristics

(V_{OUT} set to 5V, $T_A = +25^\circ C$, unless otherwise noted.)

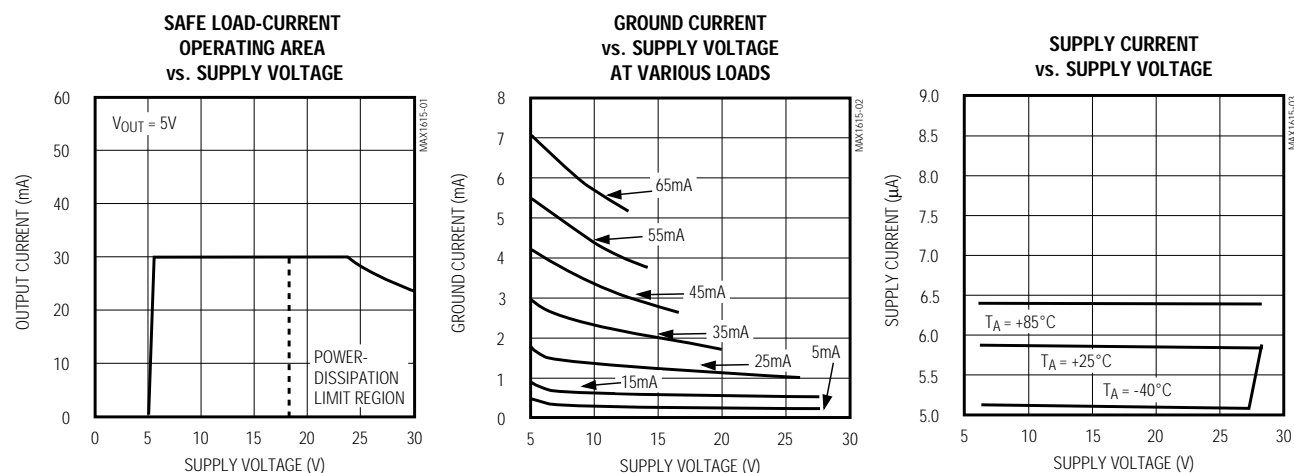

High-Voltage, Low-Power Linear Regulators for Notebook Computers

Typical Operating Characteristics (continued)

(V_{OUT} set to 5V, $T_A = +25^\circ\text{C}$, unless otherwise noted.)

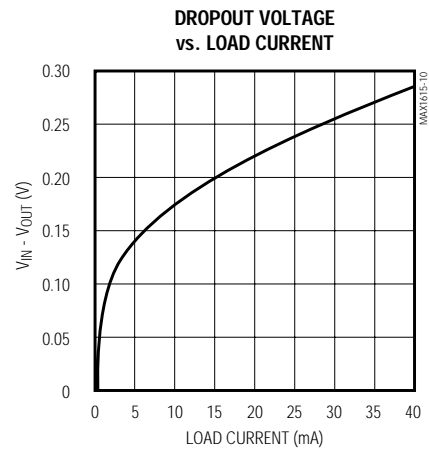
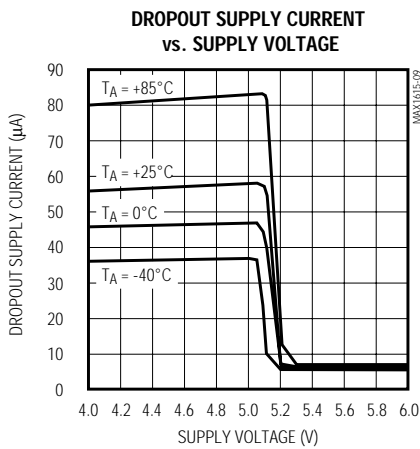
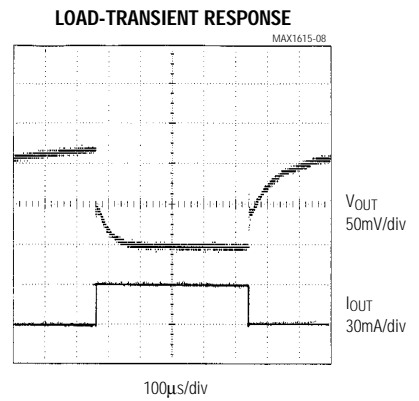
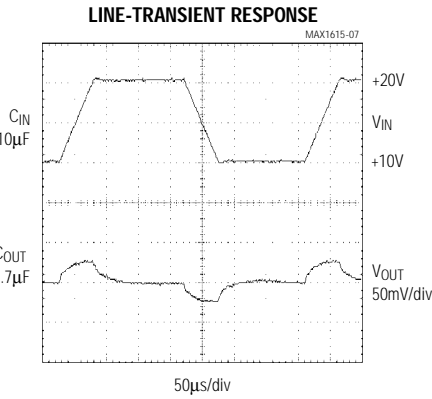
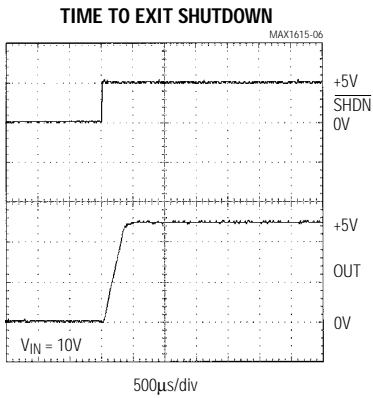
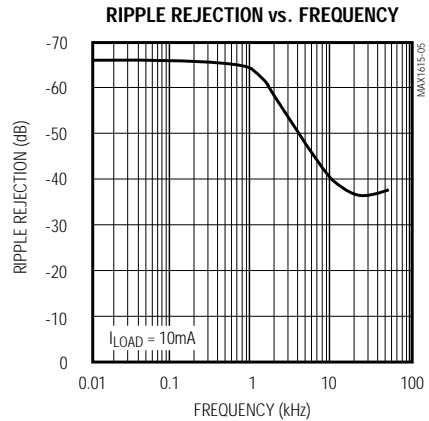
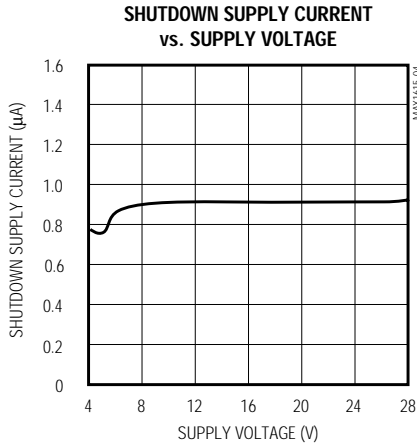

High-Voltage, Low-Power Linear Regulators for Notebook Computers

Pin Description

PIN		NAME	FUNCTION
MAX1615	MAX1616		
1	1	IN	Positive Input Voltage. Connect to a +4V to +28V supply.
2	2	GND	Ground
3	3	OUT	Regulator Output
4	—	5/3	Preset Output Voltage Select. Connect to GND for 3.3V output or to OUT for 5.0V output.
—	4	FB	Feedback Input. Regulates to 1.24V nominally.
5	5	SHDN	Shutdown, active low input. Connect to IN for automatic start up.

MAX1615/MAX1616

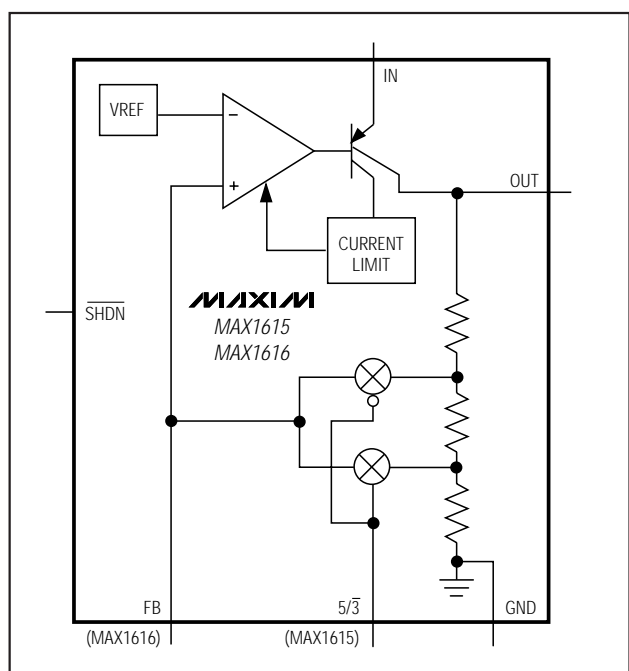

Figure 1. Functional Diagram

Detailed Description

The MAX1615/MAX1616 low-quiescent-current linear regulators are designed primarily for high input voltage applications. The MAX1615 supplies a preselected 3.3V or 5.0V output for loads up to 30mA. The MAX1616 provides an adjustable voltage from 1.24V to 28V. The maximum output current is a function of the package's maximum power dissipation for a given temperature. A 5µA load is required to maintain output regulation.

The MAX1615's output voltage is fed back through an internal resistor voltage divider connected to OUT. Set the output voltage to either 3.3V or 5.0V with the 5/3 pin. Select the 5V output by connecting 5/3 to OUT, or the 3.3V output by connecting 5/3 to GND.

The MAX1616 uses external feedback, allowing the output voltage to be set by external resistors (see *Setting the MAX1616 Output Voltage* section). The typical FB threshold is at 1.24V.

Shutdown

The device enters shutdown mode when SHDN is low. In shutdown mode, the pass transistor, control circuit, reference, and all biases turn off, reducing the supply current to below 1µA. Connect SHDN to IN for automatic start-up.

Current Limit

Output current is limited to 100mA (typical). The current limit exceeds the 30mA (max) safe operating limit. The output can be shorted to ground for 30 seconds without damaging the part.

Thermal-Overload Protection

When the junction temperature exceeds $T_J = +150^\circ\text{C}$, the thermal sensor sends a signal to the shutdown logic, turning off the pass transistor and allowing the IC to cool. The thermal sensor turns the pass transistor on again after the IC's junction temperature cools by $+20^\circ\text{C}$ (typical), resulting in a pulsating output during continuous thermal-overload conditions.

Operating Region and Power Dissipation

Maximum power dissipation depends on the thermal resistance of the case and circuit board, the temperature difference between the die junction and ambient air, and the rate of air flow. The device's power dissipa-

High-Voltage, Low-Power Linear Regulators for Notebook Computers

tion is $P = I_{OUT} (V_{IN} - V_{OUT})$. The power dissipation at +70°C ambient is 571mW (see *Absolute Maximum Ratings*). The thermal resistance junction-to-case of the SOT23-5 package is 81°C/W, and the maximum safe junction temperature is +150°C.

The GND pin performs the dual function of providing an electrical connection to ground and channeling heat away. Connect GND to ground using a large pad or ground plane.

Applications Information

Setting the MAX1616 Output Voltage

Set the MAX1616's output voltage with two resistors, R1 and R2 (Figure 2). Choose R2 = 250kΩ to maintain a 5μA minimum load and calculate R1 using the following equation:

$$R1 = R2 \left(\frac{V_{OUT}}{V_{FBT}} - 1 \right)$$

where $V_{FBT} = 1.24V$ (typical).

Capacitor Selection

Use a 0.1μF minimum capacitor on the input. Higher values will improve line-transient response.

Use 1μF minimum on the output, or 4.7μF for the full 30mA load current (6.8μF, MAX1616). Otherwise, use 1μF plus 0.125μF/mA (0.2μF/μA, MAX1616). For output voltages less than 3.3V, use 15μF instead of 6.8μF. The output capacitor's effective series resistance (ESR) must be less than 1Ω for stable operation.

Output Voltage Noise

The MAX1615/MAX1616 typically exhibit 5mVp-p of noise during normal operation. This is negligible in most applications. In applications that include analog-to-digital converters (ADCs) of more than 12 bits, consider the ADC's power-supply-rejection specifications.

Transient Response

The *Typical Operating Characteristics* show the MAX1615/MAX1616's load-transient response. Two of the output response's components can be observed on the load-transient graph: a DC shift from the output impedance due to the different load currents, and the transient response. Typical step changes in the load current from 10mA to 20mA produce 50mV transients. Increasing the output capacitor's value attenuates transient spikes.

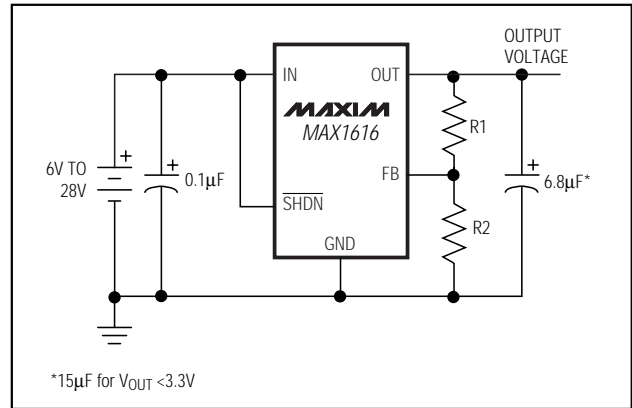

Figure 2. MAX1616 Typical Application Circuit

Table 1. Surface-Mount Capacitor Manufacturers

TYPE	MANUFACTURER	CAPACITOR
Electrolytic	AVX	TPS series
	Matsuo	267 series
	Sprague	593D, 595 series
Ceramic	AVX	X7R
	Matsuo	X7R

Table 2. Component Suppliers

SUPPLIER	PHONE	FAX
AVX	(803) 946-0690	(803) 626-3123
Matsuo	(714) 969-2491	(714) 960-6492
Sprague	(603) 224-1961	(603) 224-1430

Chip Information

TRANSISTOR COUNT: 386

High-Voltage, Low-Power Linear Regulators for Notebook Computers

Tape-and-Reel Information

MAX1615/MAX1616

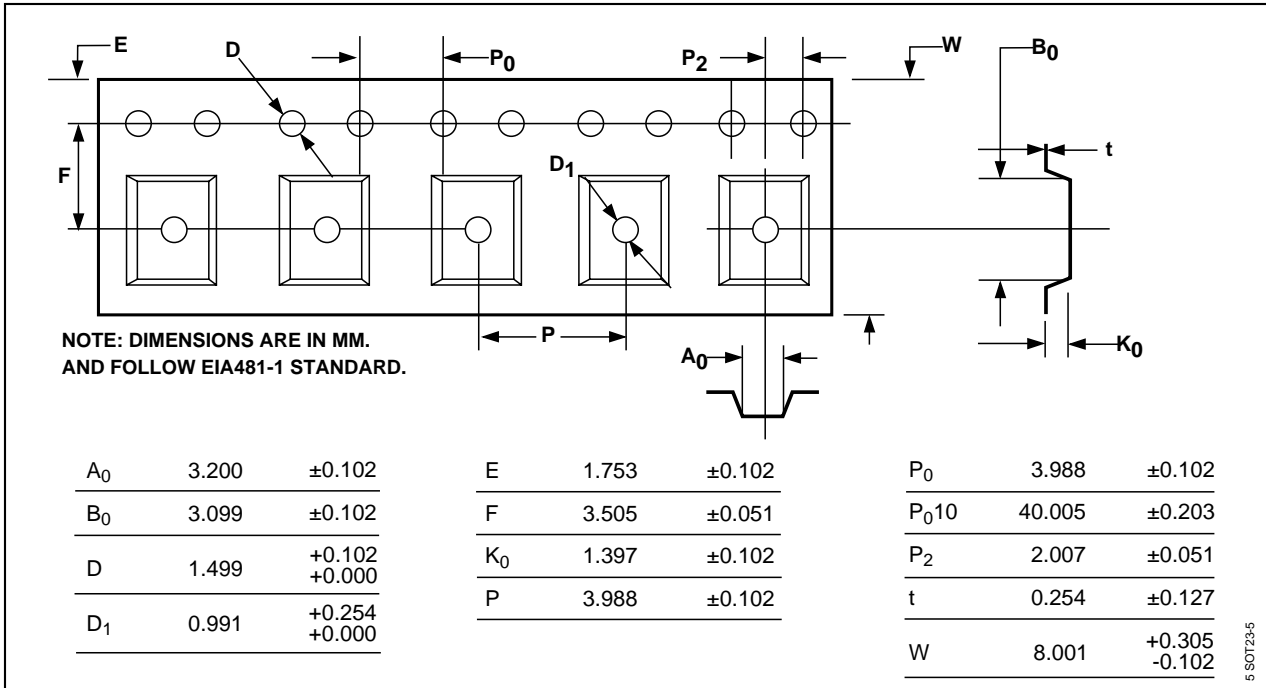

High-Voltage, Low-Power Linear Regulators for Notebook Computers

Package Information

(The package drawing(s) in this data sheet may not reflect the most current specifications. For the latest package outline information, go to www.maxim-ic.com/packages.)

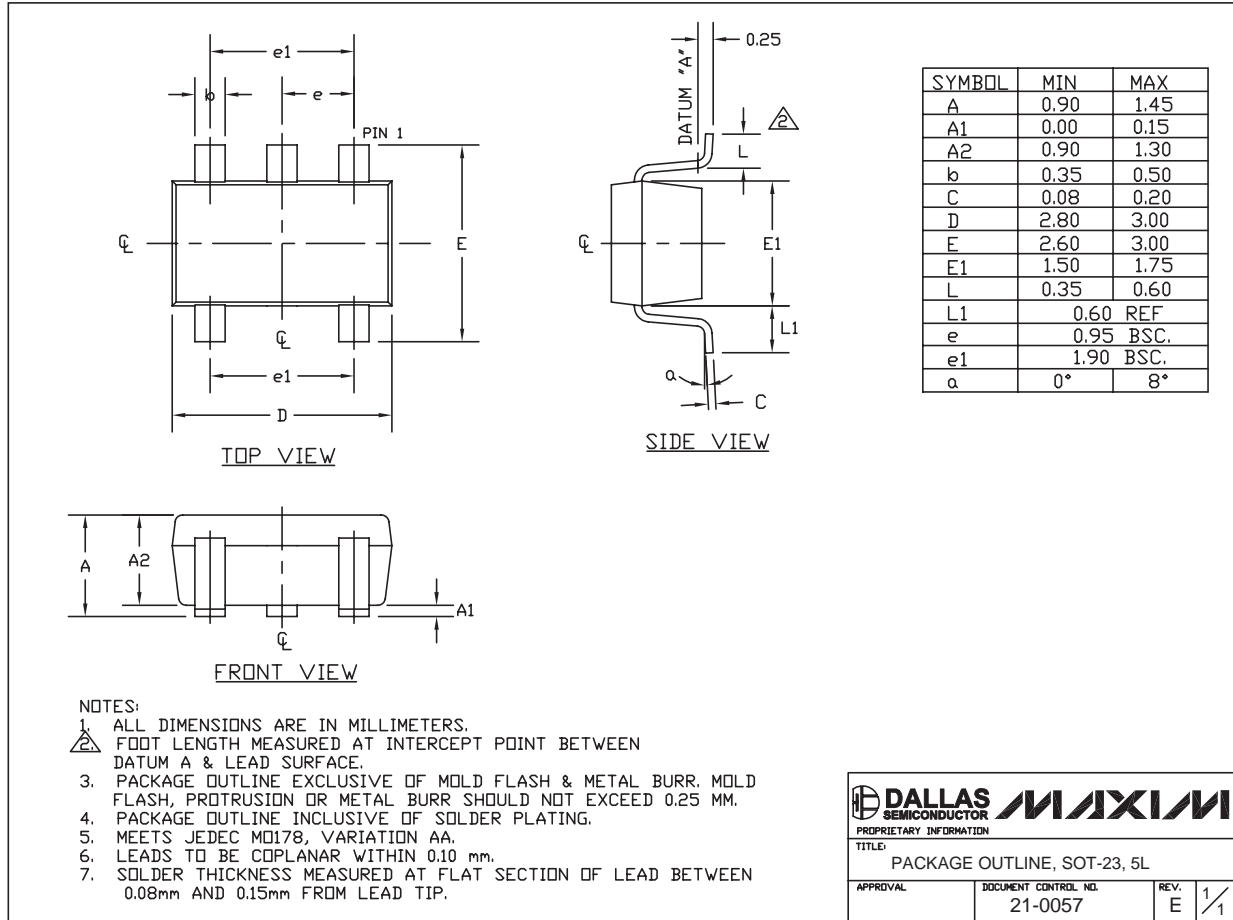

SOT-23 5L .EPS

Maxim cannot assume responsibility for use of any circuitry other than circuitry entirely embodied in a Maxim product. No circuit patent licenses are implied. Maxim reserves the right to change the circuitry and specifications without notice at any time.

8 Maxim Integrated Products, 120 San Gabriel Drive, Sunnyvale, CA 94086 408-737-7600