

## **Excellent Integrated System Limited**

Stocking Distributor

Click to view price, real time Inventory, Delivery & Lifecycle Information:

[Microsemi Analog Mixed Signal](#)  
[LXM1611-01](#)

For any questions, you can email us directly:  
[sales@integrated-circuit.com](mailto:sales@integrated-circuit.com)



THE INFINITE POWER OF INNOVATION

Not Recommended For New Design

RangeMAX™

LXM1611-01

DIGITAL DIMMING CCFL INVERTER MODULE

Production Data Sheet

**DESCRIPTION**

**RangeMAX Wide Range Dimming, Single Output Inverter.** The LXM1611 series of Direct Drive™ CCFL (Cold Cathode Fluorescent Lamp) Inverter Modules are specifically designed for driving LCD backlight lamps.

Similar to the LXM1610, the LXM1611 excels in applications where critical parameters include very wide range dimmability, high efficiency and reliable fail-safe design in a small form factor.

Unlike the LXM1610 or any traditional dimming CCFL inverters, the LXM1611 provides the designer a vastly superior display brightness range. 100:1+ brightness range is achievable with virtually any LCD display. Our wide range dimming provides exceptional display readability at less than 1% of full brightness, allowing both power savings and low ambient light operating capability (i.e. "night readable").

The LXM1611 is recommended for use in panels with low-voltage insulation on the lamp return wire.

**RangeMAX Digital Dimming Technique.** Digital dimming provides flicker-free brightness control in any wide-range dimming application. Dimming ratios greater than 100:1 can be achieved. Incorporation of a video synchronization feature allows wide ratio dimming without the display disturbances and interference seen with competitive products.

**NOTE:** For current data & package dimensions, visit our web site: <http://www.linfinity.com>. Protected By U.S. Patents: 5,923,129; 5,930,121; Patents Pending

The modules are equipped with a dimming input that permits brightness control from an external potentiometer or DC voltage source. The resultant "burst drive" that energizes the lamp was designed specifically to ensure that no premature lamp degradation occurs. (See "How RangeMAX Works" Section)

**Wide Input Voltage Range.** The modules convert unregulated DC voltage from the system battery or AC adapter directly to high-frequency, high-voltage waves required to ignite and operate CCFL lamps.

**Direct Drive Technology.** The module design is based on a new Direct Drive topology, which provides a number of cost and performance advantages. The LXM1611-01 series Direct Drive inverters eliminate the classic resonant inductor and capacitors, thus reducing cost and allowing a 30% reduction in module size.

**Additional Features.** Other benefits of this new topology are fixed-frequency operation and secondary-side strike-voltage regulation.

Strike-voltage regulation minimizes corona discharge in the output transformer and related circuitry, providing longer life and higher reliability. All LXM1611 modules feature both open and shorted lamp protection.

The LXM1611 is fully customizable (electronically and mechanically) to specific customer requirements.

**KEY FEATURES**

- RangeMAX Wide Range Dimming
- 8V to 18V Input Voltage Range
- 30% Smaller Than CS-ZVS Models
- Easy To Use Brightness Control
- MicroAmp SLEEP Mode
- Output Short-Circuit Protection And Automatic Strike-Voltage Regulation
- 7.3mm Max. Module Height, 16mm Module Width
- Fixed Frequency Operation

**APPLICATIONS**

- Notebook And Sub-Notebook Computers
- Portable Instrumentation
- Desktop Displays
- Low Ambient Light Conditions (i.e. Aircraft Cabins, Automobile)

**BENEFITS**

- High Efficiency And Sleep Mode Feature Extends Computer Battery Life
- Smooth, Flicker Free 1-100% Full-Range Brightness Control Gives Your Product A High Quality Image
- Output Open Circuit Voltage Regulation Minimizes Corona Discharge For Long Life And High Reliability
- Power Efficient, "Low Brightness" Capability Allows For Advanced Power Management

**PRODUCT HIGHLIGHT**

RANGEMAX VS. ANALOG DIMMING

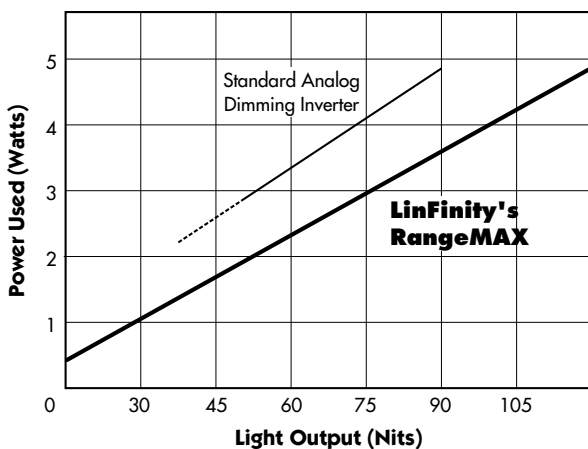

- RangeMAX technology allows the designer to operate in a lower "brightness" and therefore at lower "power consumption" than can be reached using traditional analog dimming inverters.
- Dotted line indicates area where panel variations and parasitics will impact minimum light level with analog dimming.
- Data presented for a RangeMAX inverter driving a 13.3" LCD with a 1.2 Nit to 120 Nit brightness range. The minimum power levels were 0.4 watts (RangeMAX) vs. 2.1 watts (analog dimming) for a power consumption savings of 1.7 watts.

**MODULE ORDER INFORMATION**

LXM1611-01

# LXM1611-01

# RangeMAX™

## DIGITAL DIMMING CCFL INVERTER MODULE

### Production Data Sheet

#### ABSOLUTE MAXIMUM RATINGS (Note 1)

Input Supply Voltage ( $V_{IN}$ )	-0.3V to 18V
Output Voltage, no load	Internally Limited to 1800V <sub>RMS</sub>
Output Current	10.0mA <sub>RMS</sub> (Internally Limited)
Output Power	6.0W
Input Signal Voltage (BRITE Input)	-0.3V to 6.5V
Input Signal Voltage (SLEEP, $V_{SYNCC(-)}$ , $V_{SYNCC(+)}$ Inputs)	-0.3V to $V_{IN}$
Ambient Operating Temperature	0°C to 70°C
Storage Temperature Range	-40°C to 85°C

Note 1. Exceeding these ratings could cause damage to the device. All voltages are with respect to Ground. Currents are positive into, negative out of the specified terminal.

#### RECOMMENDED OPERATING CONDITIONS (R.C.)

This module has been designed to operate over a wide range of input and output conditions. However, best efficiency and performance will be obtained if the module is operated under the condition listed in the 'R.C.' column. Min. and Max. columns indicate values beyond which the inverter, although operational, will not function optimally.

Parameter	Symbol	Recommended Operating Conditions			Units
		Min.	R.C.	Max.	
Input Supply Voltage Range (Functional)	$V_{IN}$	8	12	18	V
Input Supply Voltage (Fully Regulated Lamp Current)		9	12	16	V
Output Power	$P_O$		4	5	W
Brightness Control Input Voltage Range	$V_{BRT ADJ}$	0.0		2.5	V
Lamp Operating Voltage	$V_{LAMP}$	300	675	800	V <sub>RMS</sub>
Lamp Current (Full Brightness)	$I_{OLAMP}$		7.0		mA <sub>RMS</sub>
Operating Ambient Temperature Range	$T_A$	0		70	°C

#### ELECTRICAL CHARACTERISTICS

Unless otherwise specified, these specifications apply over the recommended operating conditions and 25°C ambient temperature for the LXM1611.

Parameter	Symbol	Test Conditions	LXM1611-01			Units
			Min.	Typ.	Max.	
<b>Output Pin Characteristics</b>						
Full Bright Lamp Current	$I_{L(MAX)}$	$V_{BRT ADJ} = 2.5V_{DC}$ , SLEEP = HIGH, Burst Duty = 100%, $V_{IN} = 9V_{DC}$	6.3	7.0	7.7	mA <sub>RMS</sub>
Minimum Lamp Current (Note 2)	$I_{L(MIN)}$	$V_{BRT ADJ} = 0V_{DC}$ , SLEEP = HIGH, Burst Duty = 2%, $V_{IN} = 9V_{DC}$		0.14		mA <sub>RMS</sub>
Lamp Start Voltage	$V_{LS}$	0°C < $T_A$ < 40°C, $V_{IN} \geq 7.0V_{DC}$	1500		1800	V <sub>RMS</sub>
Operating Frequency	$f_O$	$V_{BRT ADJ} = 2.5V_{DC}$ , SLEEP = HIGH, $V_{IN} = 12V_{DC}$	52	57	62	KHz
<b>BRITE Input</b>						
Input Current	$I_{BRT}$	$V_{BRT ADJ} = 0V_{DC}$	-10	-12	-14	$\mu A_{DC}$
Input Voltage for Max. Lamp Current	$V_C$	$I_{O(LAMP)} = 100\%$ Duty Cycle		2.5	2.6	V <sub>DC</sub>
Input Voltage for Min. Lamp Current	$V_C$	$I_{O(LAMP)} = \text{Minimum Duty Cycle}$		0	0	V <sub>DC</sub>
<b>SLEEP Input</b>						
RUN Mode	$V_{SLEEP(HI)}$		2.2		$V_{IN}$	V <sub>DC</sub>
SLEEP Mode	$V_{SLEEP(LO)}$		-0.3		0.8	V <sub>DC</sub>
Input Current	$I_{SLEEP}$	SLEEP = 5.0V		120	180	$\mu A_{DC}$
<b><math>V_{SYNCC(-)}</math> / <math>V_{SYNCC(+)}</math> Characteristics</b>						
Logic High Level	$V_{SYNCH(HI)}$		4.0		6.5	V <sub>DC</sub>
Logic Low Level	$V_{SYNCH(LO)}$		-0.3		1.0	V <sub>DC</sub>
Input Impedance	$Z_{IN}$		60	66	75	k $\Omega$
Pulse Width (Note 3)	$t_{PW}$		25		250	$\mu s$
Input Frequency	$f_{SYNC}$		49		150	Hz
<b>Power Characteristics</b>						
Sleep Current	$I_{IN(MIN)}$	$V_{IN} = 15V_{DC}$ , SLEEP $\leq 0.8V$		10	50	$\mu A_{DC}$

Note 2. Minimum lamp current required to maintain even light output may vary with display panel.

3. The module will be functional with pulse widths much larger than 250 $\mu s$ , but will have limited dimming.



**RangeMAX™**

**LXM1611-01**

**DIGITAL DIMMING CCFL INVERTER MODULE**

Production Data Sheet

**FUNCTIONAL PIN DESCRIPTION**

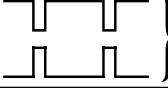
Conn.	Pin	Description
<b>CN1</b>		
CN1-1 CN1-2	V <sub>IN</sub>	Input Power Supply. ( $8V \leq V_{IN} \leq 18V$ )
CN1-3 CN1-4	GND	Power Supply Return.
CN1-5	SLEEP	ON/OFF Control. ( $2.2V < \overline{SLEEP} < V_{IN} = \text{ON}$ , $-0.3V < \overline{SLEEP} < 0.8V = \text{OFF}$ )
CN1-6	BRITE	Brightness Control ( $-0.3$ to $2.5V_{DC}$ ). $2.5V_{DC}$ gives maximum lamp current.
CN1-7	V <sub>SYNC(-)</sub>	Vertical synchronization input, negative going.
CN1-8	V <sub>SYNC(+)</sub>	Vertical synchronization input, positive going.
		 } $25\mu s < t_{pw} < 250\mu s$ , $49Hz < f_{sync} < 150Hz$
<b>CN2</b>		
CN2-1	V <sub>HI</sub>	High voltage connection to high side of lamp. Connect to lamp terminal with shortest lead length. <b>DO NOT</b> connect to ground.
CN2-2	V <sub>LO</sub>	Connection to low side of lamp. Connect to lamp terminal with longer lead length. <b>DO NOT</b> connect to Ground.

**PHYSICAL DIMENSIONS**

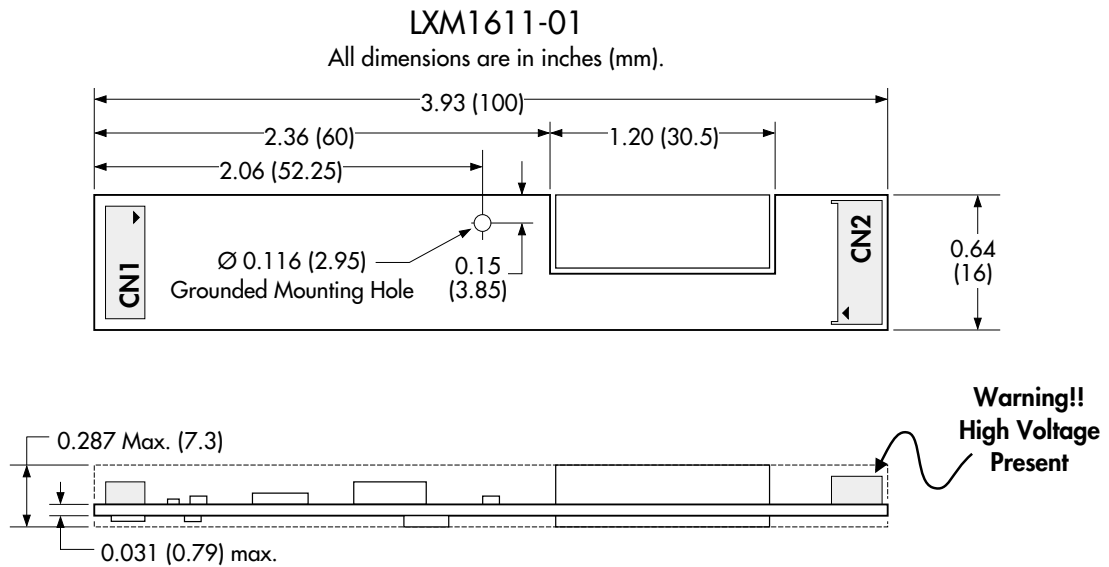

**Connectors:**

**CN-1** = MOLEX 53261-0890

**CN-2** = JST SM02(8.0) B-BHS-TB

**Recommended Mate:**

Pins: 50079-8100\*, Housing: 51021-0800  
 \* Loose (-8000, Chain) Recommended #26 AWG wiring

Pins: 5BH-001T-P0.5, Housing: BHR-03VS-1

**LXM1611-01**

**RangeMAX™**

**DIGITAL DIMMING CCFL INVERTER MODULE**

Production Data Sheet

**HOW RANGEMAX WORKS**

**LAMP VOLTAGE & LAMP CURRENT — Burst Mode Operation**

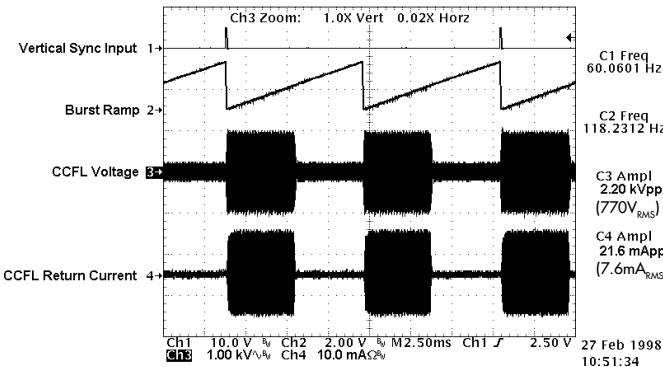

**FIGURE 1 — 50% Burst Duty Cycle**

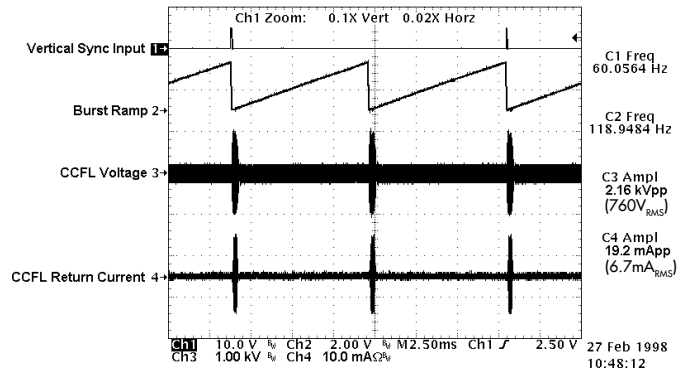
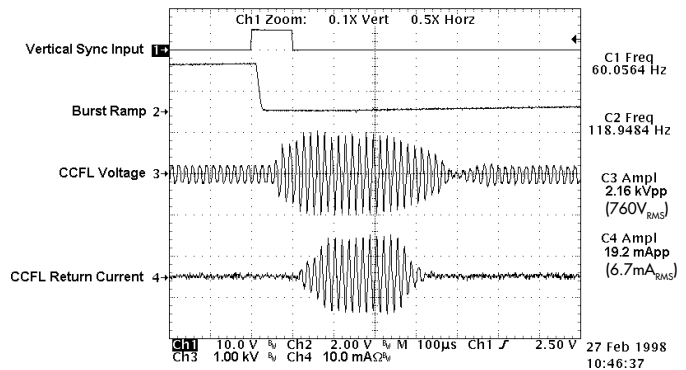

**FIGURE 2 — 2% Burst Duty Cycle**

Rather than using the traditional dimming technique of varying lamp current magnitude to adjust light output, RangeMAX inverters use a fixed lamp current value with a duty cycle control method.

The lamp current burst width can be modulated from 100% (continuous lamp current) down to a 2% duty cycle, allowing the lamp to be dimmed to less than 1% of its full brightness.

As can be seen in Trace 4 of Figure 3 photo at right, careful design consideration was given to controlling lamp start voltage to softly start current flow. This eliminates current overshoot that can result in premature cathode wear and reduce lamp life.



**FIGURE 3 — 2% Burst Duty Cycle (Expanded Time Base)**

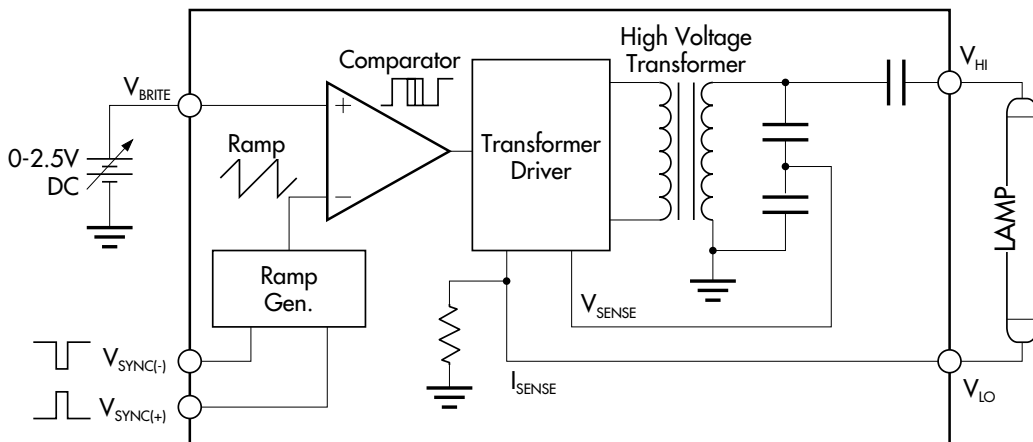

**FIGURE 4 — RangeMAX Block Diagram**

**RangeMAX™**

**LXM1611-01**

**DIGITAL DIMMING CCFL INVERTER MODULE**

Production Data Sheet

**HOW RANGEMAX WORKS** (continued)

**HIGHLIGHTS**

- On-board brightness control circuit includes a DC voltage to pulse width converter that minimizes system design work and system noise susceptibility. This provides a familiar and convenient interface while reducing the potential for externally induced noise which can cause lamp flicker.
- An on-board oscillator operates the inverter BURST rate above 95Hz, well beyond standard 50/60Hz video refresh rates where the eye can perceive pulsing light.
- RangeMAX inverter modules are designed to operate with the burst frequency synchronized to the video frame rate. This provides operation with no visible display disturbances caused by beat frequencies between the lamps and video frame rates.
- In applications with no access to a vertical sync, the inverter burst frequency can be allowed to "free run" at 95Hz. In this non-synchronous mode, minor display disturbances can be found under certain video conditions. This performance may be acceptable for many applications, but synchronization must be used when no disturbance can be tolerated.
- Separate inputs are provided for negative and positive vertical sync pulses so external inversion is not needed.
- Separate feedback loops for lamp current and open circuit voltage regulation insure reliable strike under all operating conditions, automatic over-voltage prevention with broken or failed lamps, and accurate lamp current regulation.

**TYPICAL APPLICATION**

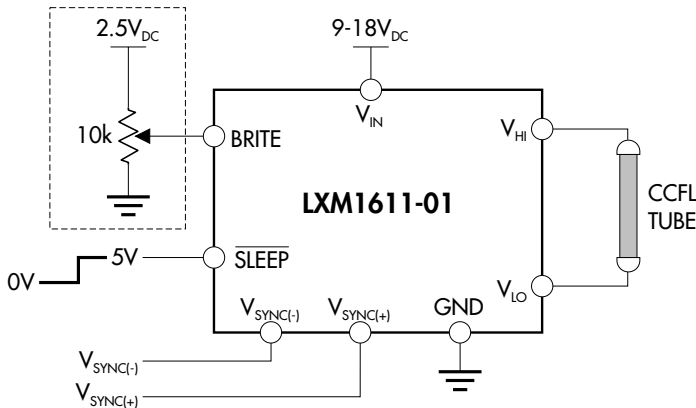

**FIGURE 5** — Potentiometer Brightness Control

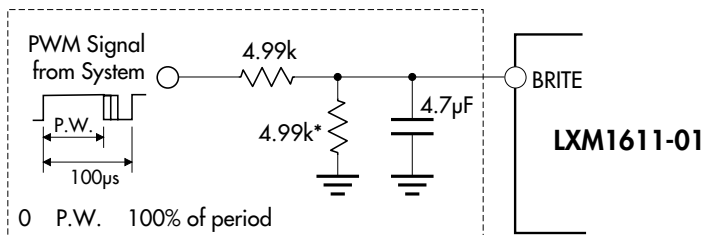

\* Use 4.99k for 5V PWM amplitude, 15k for 3.3V PWM amplitude, and omit for 2.5V PWM amplitude.

**FIGURE 5A** — PWM Brightness Control

- The brightness control may be a simple 10k potentiometer or a voltage output DAC. A PWM signal from a micro-controller may also be used with a suitable filter such as shown in Figure 5A.
- If synchronization to the video framerate is desired, connect the vertical sync pulse from the system video controller to the appropriate  $V_{SYNC}$  input. If the pulse is negative going (▬▬▬), connect it to  $V_{SYNC(-)}$ . If positive going (▬▬▬), connect it to  $V_{SYNC(+)}$ . If no video synchronization is desired, leave both  $V_{SYNC(-)}$  and  $V_{SYNC(+)}$  floating.
- If you need to turn the inverter ON/OFF remotely, connect a 3V or 5V logic signal to the SLEEP input. If remote ON/OFF is not needed, connect the SLEEP input to  $V_{IN}$  or any other voltage greater than  $2.2V_{DC}$ .
- Connect  $V_{HI}$  to high voltage wire from the lamp. Connect  $V_{LO}$  to the low voltage wire (wire with thinner insulation). Never connect  $V_{LO}$  to circuit ground as this will defeat lamp current regulation. If both lamp wires have heavy high voltage insulation, connect the longest wire to  $V_{LO}$ .

**RangeMAX INVERTERS**

Also available in Dual Output **LXM1621-01** and Quad Output **LXM1641-01** versions for multiple lamp applications.

RangeMAX and Direct Drive are trademarks of Linnity Microelectronics Inc.

PRELIMINARY DATA - Information contained in this document is pre-production data, and is proprietary to Linnity. It may not be modified in any way without the express written consent of Linnity. Product referred to herein is offered in sample form only, and Linnity reserves the right to change or discontinue this proposed product at any time.