

Excellent Integrated System Limited

Stocking Distributor

Click to view price, real time Inventory, Delivery & Lifecycle Information:

[Pomona Electronics](#)
[1794](#)

For any questions, you can email us directly:

sales@integrated-circuit.com

Pomona®

Model 1794 BNC Female To WE-309 Phone Plug

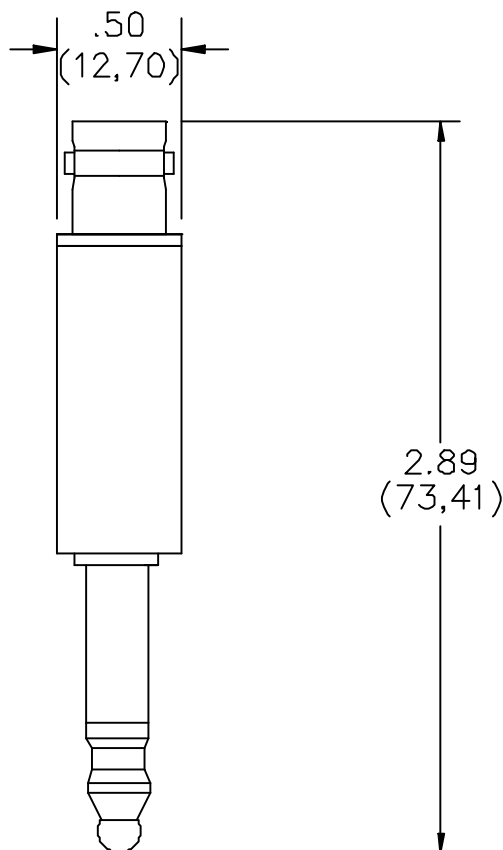

FEATURES:

- Permits BNC male to be used with equipment having three circuit phone jacks.
- Readily adapts equipment to available BNC coaxial cable.
- Tip connected to inner contact of connector and ring connected to shell.
- Sleeve, no connection.

MATERIALS:

Upper Conn: BNC Female

Finish: Body – Tarnish Resistant.

Center Contact – Gold plated Beryllium Copper per MIL-C-39012

Marking: “026-001-008”

Insulation: ABS molded to BNC Female and Phone Plug.

Color: Black

Marking: “POMONA ELECTRONICS
 MODEL 1794”

Lower Conn: Phone Plug PJ-068

Brass (Equivalent to WE-309)

RATINGS:

Operating Temperature: +50°C (+122°F) Max.

Operating Voltage: 500 V Peak

ORDERING INFORMATION: Model 1794

All dimensions are in inches. Tolerances (except noted): .xx = ±.02” (.51 mm), .xxx = ±.005” (.127 mm).

All specifications are to the latest revisions. Specifications are subject to change without notice.

Registered trademarks are the property of their respective companies.

Made in USA