

## Excellent Integrated System Limited

Stocking Distributor

Click to view price, real time Inventory, Delivery & Lifecycle Information:

[Pomona Electronics](#)  
[3561-0](#)

For any questions, you can email us directly:

[sales@integrated-circuit.com](mailto:sales@integrated-circuit.com)

**Model 3561, 3563, 3565, 4691**  
**Banana Jack to #12, 16, 20 & 22 Pin**

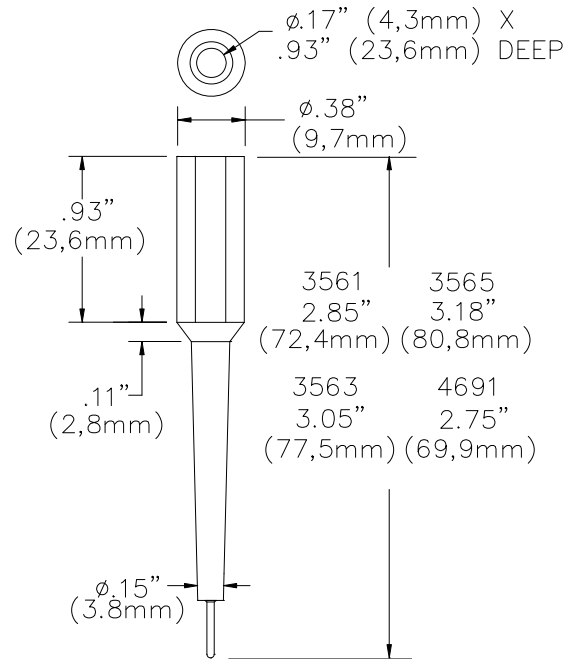

**Features**

- Ideal test adapters for rapid testing of the hard-to-get to sockets of multi-socket connectors.
- Flexible tip allows testing of adjacent contacts.
- Full insulation protects against shorting or contact damage.

**Materials**

Insulation: Polyvinyl Chloride (PVC)  
 Banana Jack Body (upper connector)  
*Material:* Brass.  
*Finish:* Bright Tin Plated  
 Pin (lower connector)  
*Material:* Brass  
*Finish:* Gold Plated over Nickel Plating

Model	Contact Size	Type	Current
4691	22 AWG .030" (.76mm)	Pin	3 Amps
3561	20 AWG .040" (1.02mm)	Pin	
3563	16 AWG .063" (1.60mm)	Pin	
3565	12 AWG .093" (2.36mm)	Pin	

**Ordering Information**

Model: **3561-\***, **3563-\***, **3565-\***, **4691-\***  
 \* = Color: -0 Black, -2 Red  
 Ordering Example: 3561-2 (red adapter)

**Voltage Rating:**

For *CE Compliance* and for personal safety, do not hold in hand when voltages exceed 33 Vrms/70 Vdc. Maximum voltage for *hands free use*: 2500 Vrms Max.

Operating Temperature: +55°C (+131°F) Max.

*Test Kit 6481:* contains 18 pieces, one red and one black adapter of each adapter: 3560, 3561, 3562, 3563, 3564, 3565, 4690, 4691 and one set of model 6358 test leads.

*For banana jack to test sockets, see models:* 3560, 3562, 3564, 4690

**USA:** Sales: 800-490-2361  
 Technical Support: [technicalsupport@pomonatest.com](mailto:technicalsupport@pomonatest.com)  
 Fax: 425-446-5844

**Europe:** 31-(0) 40 2675 150 **International:** 425-446-5500

**Where to Buy:** [www.pomonaelectronics.com](http://www.pomonaelectronics.com)

All dimensions are in inches. Tolerances (except noted): .xx = ±.02" (.51 mm), .xxx = ± .005" (.127 mm). All specifications are to the latest revisions. Specifications are subject to change without notice. Registered trademarks are the property of their respective companies.

**Model 3561, 3563, 3565, 4691**  
**Banana Jack to #12, 16, 20 & 22 Pin**



# Pomona®

The items included with this product are certified to meet IEC 1010-2-031 safety requirements.

Les éléments inclus avec ce produit sont certifiés pour répondre à des exigences de sûreté du IEC 1010-2-031.

Los items incluidos con este producto se certifican para resolver requisitos de seguridad del IEC 1010-2-031.

– Only IEC 1010 type shrouded test plugs should be used with IEC 1010 type jacks. NEVER INSERT A PROBE TIP WITH BANANA SPRING INTO A TEST ACCESSORY JACK THAT WILL BE USED AS A HAND HELD PROBING DEVICE

–Seuls les vérificateurs de tension renforcés de type IEC 1010 devraient être utilisés avec des jacks de type IEC 1010. NE JAMAIS INSERER DE BOUT DE SONDE AVEC RESSORT BANANE DANS UN JACK D'ESSAI D'ACCESSOIRES QUI SERA UTILISE COMME DISPOSITIF DE SONDAGE A MAIN.

–Se deben usar sólo tapones de prueba reforzados del tipo IEC 1010 con receptáculos de tipo IEC 1010. NUNCA INTRODUZCA UNA CLAVIJA CON UN MUELLE TIPO BANANA EN UN RECEPTACULO DE PRUEBA QUE A SU VEZ SE USE COMO APARATO DE PRUEBA MANUAL.



Both Direct and Alternating Current.  
 Courant Continu et Alternatif.  
 Corriente Directa y Alterna.



Caution ! Refer to Accompanying Documents.  
 Attention ! Se Reporter aux Documents joints.  
 ; Peligro! Consulte los Documentos Adjuntos.



Double Insulation or Reinforced Insulation.  
 Isolation Double ou Isolation Renforcée.  
 Aislamiento Doble o Aislamiento Reforzado.



Caution ! Risk of Electric Shock.  
 Attention ! Risque de Choc Électrique.  
 ; Peligro! Riesgo de Sacudida Eléctrica.

CAT

Overvoltage Category I, II, III or IV.  
 Surtension Catégorie I, II, III ou IV.  
 Sobretensión de Categoría I, II III o IV.

# Pomona Electronics



PO Box 9090, Everett, WA 98206-9090 TEL: 800-490-2361