

Excellent Integrated System Limited

Stocking Distributor

Click to view price, real time Inventory, Delivery & Lifecycle Information:

[Panasonic Electronic Components](#)
[DN8897](#)

For any questions, you can email us directly:

sales@integrated-circuit.com

DN8897/SE/TE/S

Hall IC (Operating Temperature Range
 $T_{opr} = -40$ to $+100^{\circ}\text{C}$,
 Operating in Alternative Magnetic Field)

Overview

The DN8897/SE/TE/S is a combination of a Hall element, amplifier, Schmidt circuit, and stabilized power supply/temperature compensator integrated on an identical chip by using the IC technology. It amplifies Hall element output at the amplifier, converts into a digital signal through the Schmidt circuit, and drives the TTL or MOS IC directly.

Features

- High sensitivity and low drift
- Stable temperature characteristics due to the additional temperature compensator
- Wide operating supply voltage range ($V_{CC} = 4.5$ to 16V)
- Operatig in alternative magnetic field
- TTL and MOS ICs directly drivable by output
- Provided with the output pull-up resistors (typ $27\text{k}\Omega$)
- "0" gauss point in the zero cross type hysteresis width

Applications

- Speed sensors
- Position sensors
- Rotation sensors
- Keyboard switches
- Microswitches

Note) This IC is not suitable for car electrical equipment.

Block Diagram

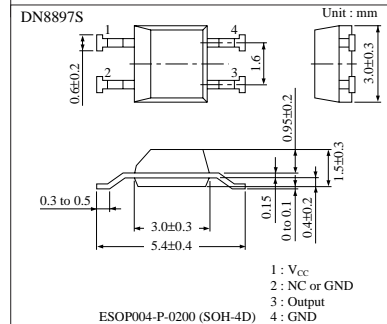
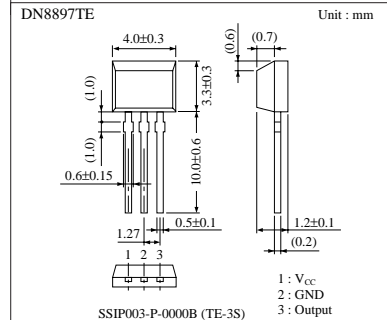
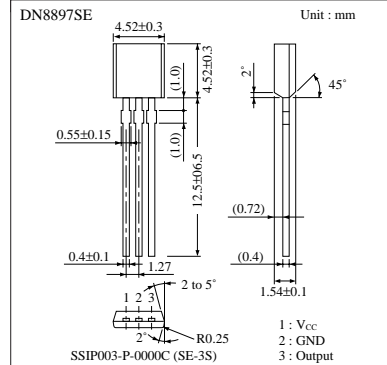
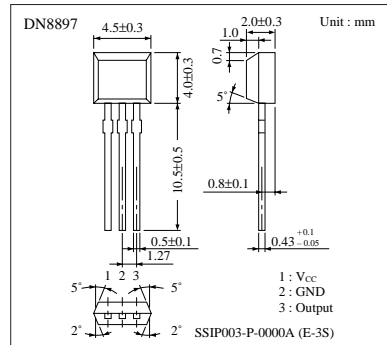
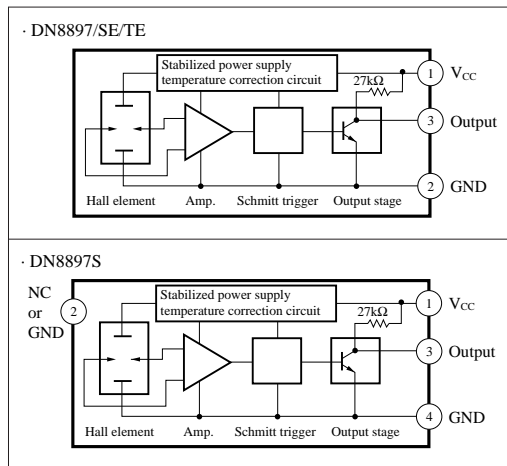

■ Absolute Maximum Ratings (Ta=25°C)

Parameter	Symbol	Rating	Unit
Supply voltage	V _{CC}	18	V
Supply current	I _{CC}	8	mA
Circuit current	I _O	20	mA
Power dissipation	P _D	150	mW
Operating ambient temperature	T _{opr}	-40 to +100	°C
Storage temperature	T _{stg}	-55 to +125	°C

■ Electrical Characteristics (Ta=25°C)

Parameter	Symbol	Condition	min	typ	max	Unit
Operating flux density	B ₁ (L→H)	V _{CC} =12V	-12	-6	-0.1	mT
	B ₂ (H→L)	V _{CC} =12V	0.1	6	12	mT
Hysteresis width	BW	V _{CC} =12V	7	10	—	mT
Output voltage	V _{OL}	V _{CC} =4.5 to 16V, I _O =12mA, B=12mT	—	—	0.4	V
	V _{OH}	V _{CC} =16V, I _O =-30μA, B=-12mT	14.7	—	—	V
V _{CC} =4.5V, I _O =-30μA, B=-12mT		2.9	—	—	V	
Output short-circuit current	-I _{OS}	V _{CC} =16V, V _O =0V, B=-12mT	0.4	—	0.9	mA
Supply current	I _{CC}	V _{CC} =16V	1	—	6	mA
		V _{CC} =4.5V	1	—	5.5	mA

■ Hall Element Position

Unit : mm
The center of the Hall element is in the hatched area in the right figure.

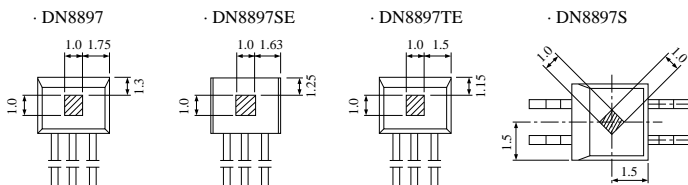

Distance from package surface to sensor (mm)	DN8897	DN8897SE	DN8897TE	DN8897S
	0.7	0.42	0.4	0.65

■ Flux-Voltage Conversion Characteristics

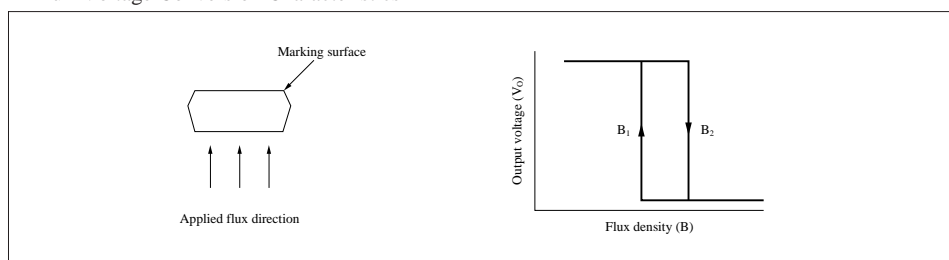

■ Precaution on Use

1. Change of the operation magnetic flux density dose not depend on the supply voltage, because the stabilization power supply is built-in. (only for the range ; $V_{CC} = 4.5$ to 16V)
2. Change from "H" to "L" level increases the supply current by approx. 1mA.

■ Characteristics Curve

Supply Voltage – Ambient Temperature

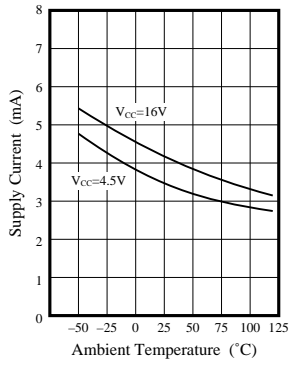

Operating Flux Density – Ambient Temperature

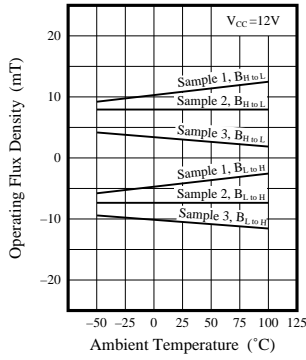

Operating Flux Density – Supply Voltage

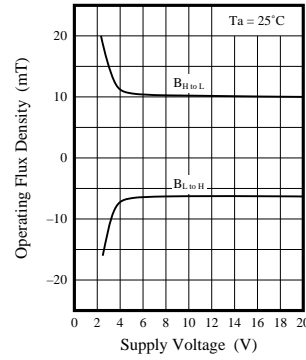

Output Low Level Voltage – Ambient Temperature

