

Excellent Integrated System Limited

Stocking Distributor

Click to view price, real time Inventory, Delivery & Lifecycle Information:

[Pomona Electronics](#)
[4005-0](#)

For any questions, you can email us directly:

sales@integrated-circuit.com

Pomona®

**Model 4005
Insulated Banana Jack With
Wire Wrapped Terminal**

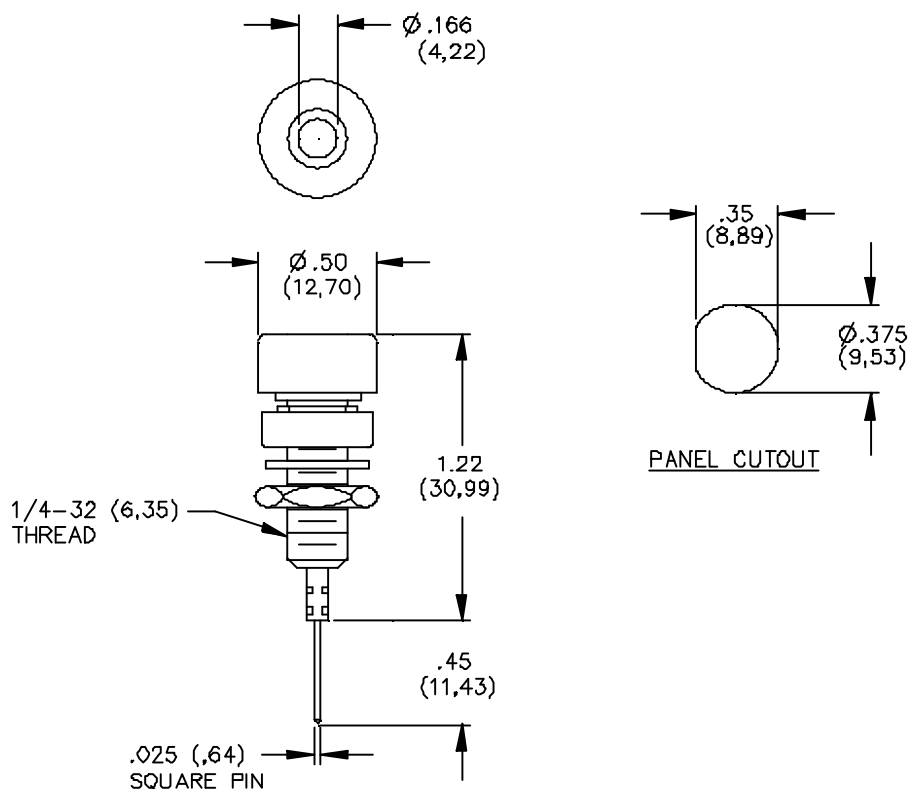

FEATURES:

- Mounts in panels from 1.60 (.063) to 9.53 (.375) thick.

MATERIALS:

Banana Jack: Nickel Plated Brass
Terminal: Gold Plated Phosphor Bronze
Insulation: Polycarbonate
Mounting Base: Polycarbonate
Lockwasher: Steel
Hex Nut: Brass

RATINGS:

Voltage: Hand-held testing: 30VAC/60VDC Max.
Hands free testing in controlled voltage environments: 2500 WVDC Max.
Operating Temperature: +115°C (+239°F) Max.
Current: 3 Amperes

ORDERING INFORMATION: Model 4005-
*=Color, -0 Black, -1 Brown, -2 Red, -3 Orange, -4 Yellow, -5 Green, -6 Blue, -7 Violet, -8 Gray, -9 White

Ordering Example: 4005-2 Color is Red
Sold in packages of 10

All dimensions are in inches. Tolerances (except noted): .xx = ±.02" (.51 mm), .xxx = ±.005" (.127 mm).
All specifications are to the latest revisions. Specifications are subject to change without notice.
Registered trademarks are the property of their respective companies. Made in USA