

Excellent Integrated System Limited

Stocking Distributor

Click to view price, real time Inventory, Delivery & Lifecycle Information:

[Pomona Electronics](#)
[4388](#)

For any questions, you can email us directly:

sales@integrated-circuit.com

Model 4388
Triaxial BNC, Hermetic Sealed, Bulkhead Receptable

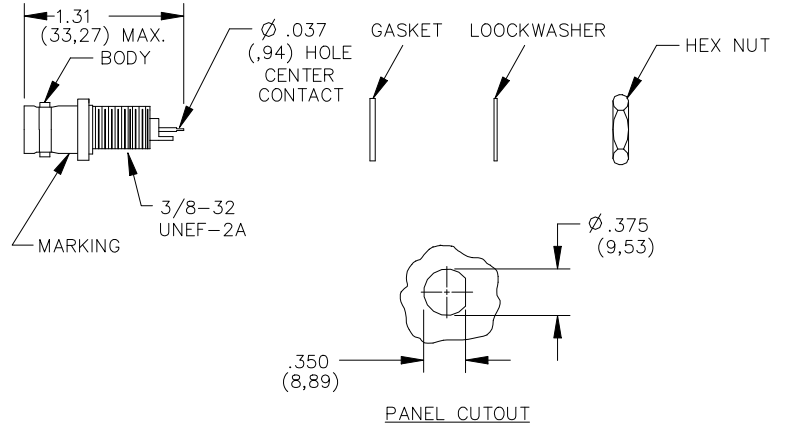
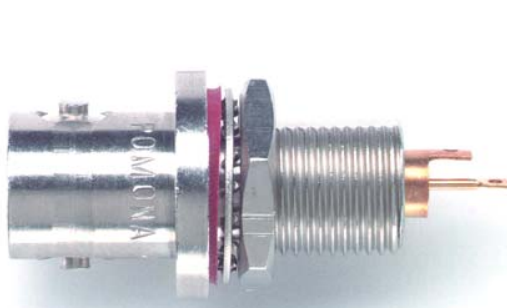

Features

- Mounts in panels up to 6.35mm (.25in)
- Hermetic Seal – 50 PSI differential pressure
- Leakage rate less than 10^{-7} cc/sec of tracer gas at one atmosphere

Materials

Body and Fittings: Brass, Alloy 360, ½ Hard

Dielectric: PTFE

Center and Intermediate Contacts: Gold Plated Beryllium Copper, Cond. HT.or Brass per body.

Gasket: Silicone rubber per ZZ-R-765, Class 11, Grade 50.

Finish: Body and Fittings – Tarnish resistant.

Center and Intermediate Contacts – Gold plate per requirements of MIL-C-49142.

Marking: POMONA 4388

Ratings

Nominal Impedance: 50Ω
 Operating Voltage: 500 Vrms
 Frequency: DC to 500 MHz
 Operating Temperature: -65°C to +165°C (-85°F to +329°F)
 Insulation Resistance: 5000 MΩ

Ordering Information

Model: 4388

USA: Sales: 800-490-2361
 Technical Support: technicalsupport@pomonatest.com
 Fax: 425-446-5844

Europe: 31-(0) 40 2675 150 **International:** 425-446-5500
 Where to Buy: www.pomonaelectronics.com

All dimensions are in inches. Tolerances (except noted): .xx = ±.02" (.51 mm), .xxx = ± .005" (.127 mm). All specifications are to the latest revisions. Specifications are subject to change without notice. Registered trademarks are the property of their respective companies.