

Excellent Integrated System Limited

Stocking Distributor

Click to view price, real time Inventory, Delivery & Lifecycle Information:

[Pomona Electronics](#)
[5290](#)

For any questions, you can email us directly:

sales@integrated-circuit.com

Pomona®

**Model 5290
 Triaxial Adapter
 2 Lug Female To Female**

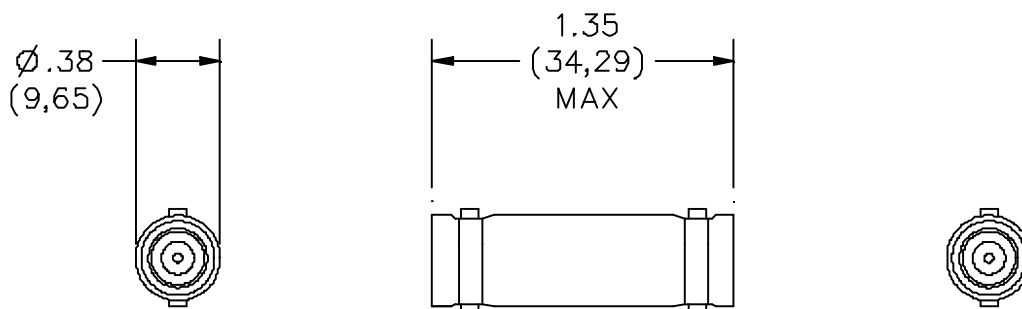

MATERIALS:

Body/Fittings: Brass per QQ-B-626, Tarnish Resistant Plating, Alloy 360, ½ Hard

Center Contact: Gold Plated Beryllium Copper per QQ-C-530, Cond. H.T. & MIL-C-39012

Dielectric: PTFE

Marking: "POMONA ELECT. 5290"

RATINGS:

Frequency Range: DC to 500 MHz.

ORDERING INFORMATION: Model 5290

All dimensions are in inches. Tolerances (except noted): .xx = ±.02" (.51 mm), .xxx = ± .005" (.127 mm).

All specifications are to the latest revisions. Specifications are subject to change without notice.

Registered trademarks are the property of their respective companies. Made in USA