

Excellent Integrated System Limited

Stocking Distributor

Click to view price, real time Inventory, Delivery & Lifecycle Information:

[Pomona Electronics](#)
[5309A](#)

For any questions, you can email us directly:

sales@integrated-circuit.com



Model 5309A
Replacement DMM Test 
Lead Set For Industrial Use

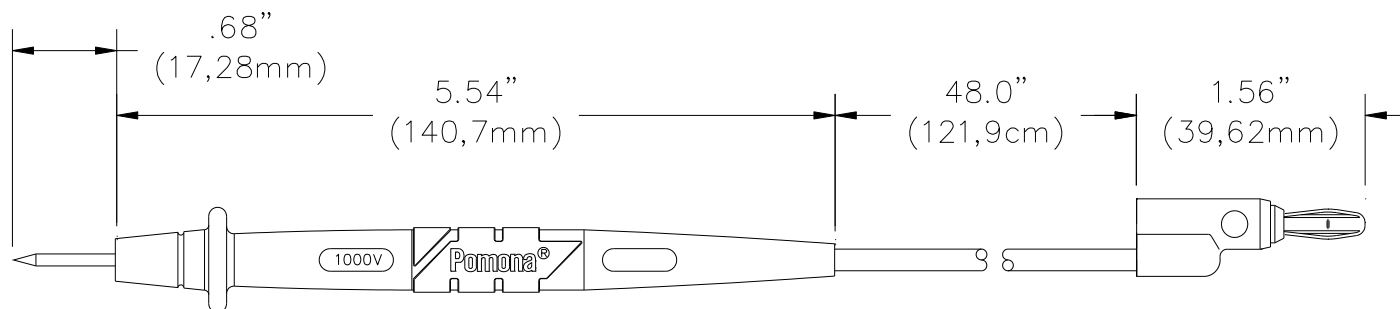

FEATURES:

- ✓ Designed for DMM's with non-sheathed banana jacks.
- ✓ Probe body incorporates a two step mold process. First step is Polypropylene for probe rigidity. Second step is Santoprene® rubber for handling comfort, added insulation protection and wire strain relief.
- ✓ Probe body and banana plug are molded directly to the wire for robust pull strength.
- ✓ Wire is a high strand count silicone wire for extreme flexibility and high temperature resistance.
- ✓ The Stainless Steel .080" (2mm) tip is provided for heavy-duty industrial applications.

MATERIALS:

Probe Body:

Outer Insulation - Santoprene® Rubber, Color: Gray

Inner Insulation – Polypropylene, Fire Retardant

Color: One Black, One Red

Tip: Stainless Steel

Wire:

18 AWG, 65 x 36 Tinned Copper Strand Silicone Insulation, Length: 48" (121,9cm), O.D. .144" (3,66mm)

Banana Plug:

Body – Brass, Nickel Plated

Spring – Beryllium Copper, Nickel Plated

Insulation: Polypropylene, Color: One Black, One Red

RATINGS:

Voltage: Hands free testing in controlled voltage environments: 1000 Vrms Max. For CE compliance: not intended for hand-held use at voltages above 33 Vrms/70 Vdc.

Current: 10 Amps

ORDERING INFORMATION:

Model 5309A (set of one Black and one Red test lead)

All dimensions are in inches. Tolerances (except noted): .xx = ±.02" (.51 mm), .xxx = ±.005" (.127 mm).

All specifications are to the latest revisions. Specifications are subject to change without notice.

Registered trademarks are the property of their respective companies.

Sales: 800-490-2361 Fax: 888-403-3360 Technical Support: 800-241-2060 (technicalsupport@pomonatest.com)
For "Where to Buy" information, visit the Pomona web site at www.pomonaelectronics.com



Model 5309A
Replacement DMM Test 
Lead Set For Industrial Use

Pomona®

The items included with this product are certified to meet IEC 1010-2-031 safety requirements.

Les éléments inclus avec ce produit sont certifiés pour répondre à des exigences de sûreté du IEC 1010-2-031.

Los items incluidos con este producto se certifican para resolver requisitos de seguridad del IEC 1010-2-031.

– Only IEC 1010 type shrouded test plugs should be used with IEC 1010 type jacks. NEVER INSERT A PROBE TIP WITH BANANA SPRING INTO A TEST ACCESSORY JACK THAT WILL BE USED AS A HAND HELD PROBING DEVICE

–Seuls les vérificateurs de tension renforcés de type IEC 1010 devraient être utilisés avec des jacks de type IEC 1010. NE JAMAIS INSERER DE BOUT DE SONDE AVEC RESSORT BANANE DANS UN JACK D'ESSAI D'ACCESSOIRES QUI SERA UTILISE COMME DISPOSITIF DE SONDAGE A MAIN.

–Se deben usar sólo tapones de prueba reforzados del tipo IEC 1010 con receptáculos de tipo IEC 1010. NUNCA INTRODUZCA UNA CLAVIJA CON UN MUELLE TIPO BANANA EN UN RECEPTACULO DE PRUEBA QUE A SU VEZ SE USE COMO APARATO DE PRUEBA MANUAL.



Both Direct and Alternating Current.
 Courant Continu et Alternatif.
 Corriente Directa y Alterna.



Caution ! Refer to Accompanying Documents.
 Attention ! Se Reporter aux Documents joints.
 ¡ Peligro! Consulte los Documentos Adjuntos.



Double Insulation or Reinforced Insulation.
 Isolation Double ou Isolation Renforcée.
 Aislamiento Doble o Aislamiento Reforzado.



Caution ! Risk of Electric Shock.
 Attention ! Risque de Choc Électrique.
 ¡ Peligro! Riesgo de Sacudida Eléctrica.

CAT

Overvoltage Category I, II, III or IV.
 Surtension Catégorie I, II, III ou IV.
 Sobretensión de Categoría I, II III o IV.

Pomona Electronics 

PO Box 9090, Everett, WA 98206-9090 TEL:800-490-2361

All dimensions are in inches. Tolerances (except noted): .xx = ±.02" (.51 mm), .xxx = ± .005" (.127 mm).

All specifications are to the latest revisions. Specifications are subject to change without notice.

Registered trademarks are the property of their respective companies.

Sales: 800-490-2361 Fax: 888-403-3360 Technical Support: 800-241-2060 (technicalsupport@pomonatest.com)
 For "Where to Buy" information, visit the Pomona web site at www.pomonaelectronics.com