

Excellent Integrated System Limited

Stocking Distributor

Click to view price, real time Inventory, Delivery & Lifecycle Information:

[Pomona Electronics](#)
[6708](#)

For any questions, you can email us directly:

sales@integrated-circuit.com

Pomona®

Model 6708: Type F Connector, Gold Plated For RG59 Cable

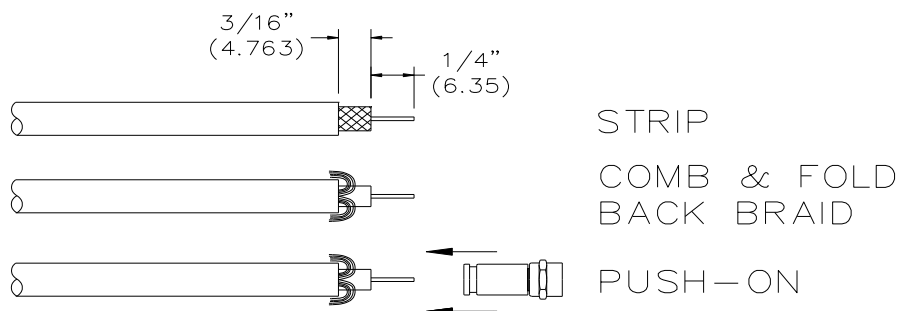
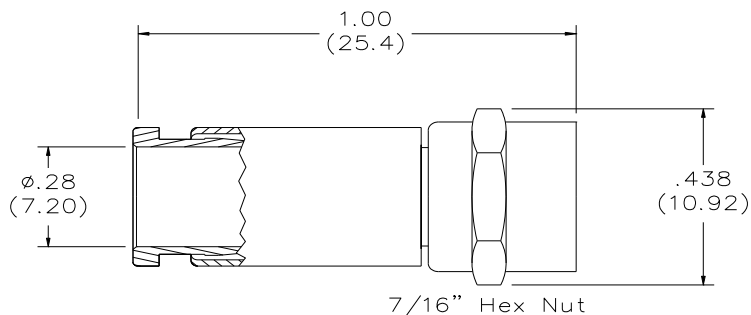

Features:

- ✓ Designed for RG 59 Cable
- ✓ Quick three step installation process: Strip, Comb and Push-on.
- ✓ No Crimp tool required

Materials:

Connector Body: Gold plated brass
 Ferrule: Gold plated annealed copper
 Insulator: Delrin

Ratings:

Impedance: 75 ohms
 Frequency: 0 to 500 MHz
 VSWR: 1.5 max
 Insulation Resistance: 5000 Megohms min.
 Contact Resistance: 3 Milliohms max.
 Voltage: *500Vrms
 Temperature: -40 to 65 C
 Durability: 500 matings
 Cable Retention: 40lbs. min.

**Hands free testing in controlled voltage environment; For CE compliance: not intended for hand held use at voltages above 33Vms/70 Vdc*

All dimensions are in inches. Tolerances (except noted): .xx = ±.02" (.51 mm), .xxx = ± .005" (.127 mm).

All specifications are to the latest revisions. Specifications are subject to change without notice.

Registered trademarks are the property of their respective companies. Made in USA

Sales: 800-490-2361 Fax: 888-403-3360 Technical Assistance: 800-241-2060
 For "Where to Buy" information, visit the Pomona web site at www.pomonaelectronics.com