



# RSF10 Series

## High level switch for boiling water



- **Pivot out of liquid**
- **High level switch position**
- **WRAS approved for use in hot & cold water**
- **Many variants are UL recognised components File No. E171218**
- **Flying lead or M12 connector**

Technical Specification	RSF14	RSF18	RSF16
Material	Polypropylene WRAS approved	Polypropylene UL approved	Polyphenylene Sulphide (PPS)
Colour	Opaque	White	Grey
Temp. Range °C	-20 / +100	-20 / +100	-10 / +120 *
°F	-4 / +212	-4 / +212	+14 / +248 *
Min. Fluid SG	0.70	0.80	0.75
Must close level (SG=1)	39mm	39mm	33mm
Must open level (SG=1)	24mm	24mm	22mm

\* Maximum temperature requires ETFE cable to be specified.

Electrical Specification	25W (Y code)	100W (H code)
Contact Form	N/C (N/O)	N/C (N/O)
Switching Power Max VA	25	100
Switching Voltage AC Max V	240	300
Switching Voltage DC Max V	120	300
Switching Current Max A	0.6	1

All ratings are for resistive load only.

The RSF10 series drop float has been designed to eliminate problems associated with limescale build up around the pivot point of a conventional float switch. It is also suitable in more viscous liquids, that might affect the pivot action of a standard float type. This particular series is primarily for applications where a high level condition has to be monitored.

The drop float actuator allows the switch housing and float pivots to be located above the surface of the liquid and provides a normally closed switch contact, opening as the liquid level rises. They are manufactured in a range of materials, with a choice of gasket material, to suit most commonly used liquids. Typical applications include wall kettles and hot vending machines. Versions available with either flying leads or M12 circular connector. There are cable sets available for use with M12 connector versions.

Standard Parts	Material	Approvals	Max Power	Leadouts	Gasket
RSF14H100RF	PP	WRAS	100VA	1 metre PVC 16/0.2	Nitrile
RSF14Y100RF	PP	WRAS	25VA	1 metre PVC 16/0.2	Nitrile
RSF16H050TG	PPS	WRAS & UL	100VA	50cm ETFE 19/0.2	Viton
RSF16H100RF	PPS	WRAS & UL	100VA	1 metre PVC 16/0.2	Nitrile
RSF16Y050TG	PPS	WRAS & UL	25VA	50cm ETFE 19/0.2	Viton
RSF16Y100RF	PPS	WRAS & UL	25VA	1 metre PVC 16/0.2	Nitrile
RSF18H100RF	PP (UL)	UL	100VA	1 metre PVC 16/0.2	Nitrile
RSF18Y100RF	PP (UL)	UL	25VA	1 metre PVC 16/0.2	Nitrile
RSF14HFP	PP	WRAS	100VA	M12 connector	Nitrile
RSF14YFP	PP	WRAS	25VA	M12 connector	Nitrile
RSF16HFP	PPS	WRAS & UL	100VA	M12 connector	Nitrile
RSF16YFP	PPS	WRAS & UL	25VA	M12 connector	Nitrile
RSF18HFP	PP (UL)	UL	100VA	M12 connector	Nitrile
RSF18YFP	PP (UL)	UL	25VA	M12 connector	Nitrile

Custom versions can be made for particular applications. Please contact Cynergy3 with your requirements.

### Mechanical Dimensions

All dimensions are in millimetres (inches)

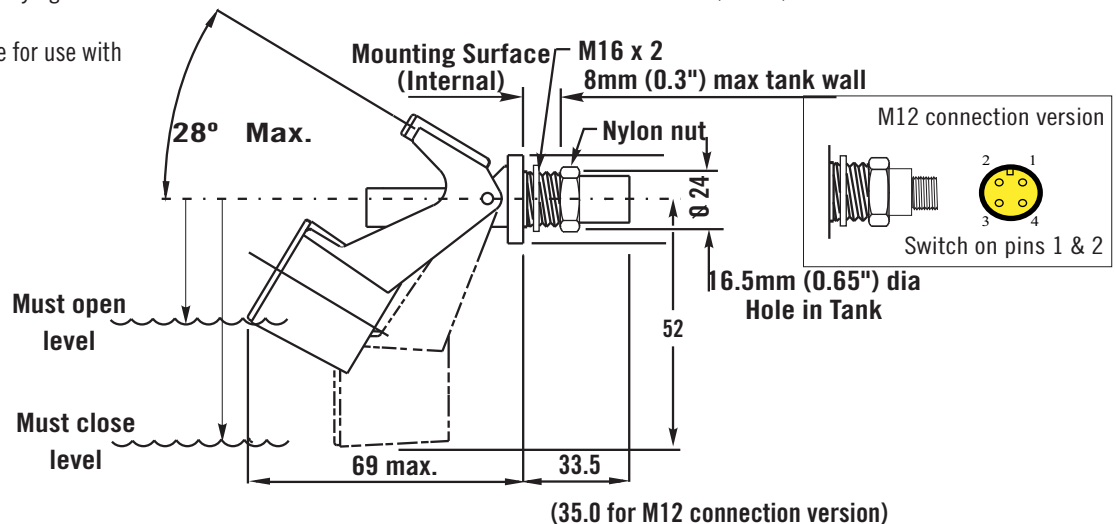

Cynergy3 Components Ltd.  
7 Cobham Road  
Ferndown Industrial Estate  
Wimborne, Dorset BH21 7PE  
Telephone +44 (0) 1202 897969  
Email:sales@cynergy3.com

ISO9001 CERTIFIED

www.cynergy3.com